

STUDENT NUMBER

								Letter
--	--	--	--	--	--	--	--	--------

**SPECIALIST MATHEMATICS****Written examination 2**

Monday 8 November 2021

Reading time: 3.00 pm to 3.15 pm (15 minutes)

Writing time: 3.15 pm to 5.15 pm (2 hours)

**QUESTION AND ANSWER BOOK****Structure of book**

<i>Section</i>	<i>Number of questions</i>	<i>Number of questions to be answered</i>	<i>Number of marks</i>
A	20	20	20
B	6	6	60
			Total 80

- Students are permitted to bring into the examination room: pens, pencils, highlighters, erasers, sharpeners, rulers, a protractor, set squares, aids for curve sketching, one bound reference, one approved technology (calculator or software) and, if desired, one scientific calculator. Calculator memory DOES NOT need to be cleared. For approved computer-based CAS, full functionality may be used.
- Students are NOT permitted to bring into the examination room: blank sheets of paper and/or correction fluid/tape.

**Materials supplied**

- Question and answer book of 27 pages
- Formula sheet
- Answer sheet for multiple-choice questions

**Instructions**

- Write your **student number** in the space provided above on this page.
- Check that your **name** and **student number** as printed on your answer sheet for multiple-choice questions are correct, **and** sign your name in the space provided to verify this.
- Unless otherwise indicated, the diagrams in this book are **not** drawn to scale.
- All written responses must be in English.

**At the end of the examination**

- Place the answer sheet for multiple-choice questions inside the front cover of this book.
- You may keep the formula sheet.

**Students are NOT permitted to bring mobile phones and/or any other unauthorised electronic devices into the examination room.**

**SECTION A – Multiple-choice questions****Instructions for Section A**

Answer **all** questions in pencil on the answer sheet provided for multiple-choice questions.

Choose the response that is **correct** for the question.

A correct answer scores 1; an incorrect answer scores 0.

Marks will **not** be deducted for incorrect answers.

No marks will be given if more than one answer is completed for any question.

Unless otherwise indicated, the diagrams in this book are **not** drawn to scale.

Take the **acceleration due to gravity** to have magnitude  $g \text{ ms}^{-2}$ , where  $g = 9.8$

**Question 1**

$$\text{Let } f(x) = \frac{1}{\sec(3x) + \frac{3}{2}}.$$

The number of asymptotes that the graph of  $f$  has in the interval  $\left[-\frac{\pi}{6}, \pi\right]$  is

- A. 2
- B. 3
- C. 4
- D. 5
- E. 6

**Question 2**

The implied domain of the function with rule  $f(x) = \cos^{-1}(\log_e(bx))$ ,  $b > 0$  is

- A.  $(0, 1]$
- B.  $[1, e]$
- C.  $\left[\frac{1}{b}, \frac{e}{b}\right]$
- D.  $\left[\frac{1}{b}, \frac{e\pi}{b}\right]$
- E.  $\left[\frac{1}{be}, \frac{e}{b}\right]$

**Question 3**

The coordinates of the local maxima of the graph of  $y = \frac{1}{(\cos(ax)+1)^2 + 3}$ , where  $a \in \mathbb{R} \setminus \{0\}$ , are

- A.  $\left(\frac{2\pi k}{a}, \frac{1}{7}\right), k \in \mathbb{Z}$
- B.  $\left(\frac{2\pi k}{a}, \frac{1}{3}\right), k \in \mathbb{Z}$
- C.  $\left(\frac{(1+2k)\pi}{2a}, \frac{1}{4}\right), k \in \mathbb{Z}$
- D.  $\left(\frac{\pi(1+2k)}{a}, \frac{1}{4}\right), k \in \mathbb{Z}$
- E.  $\left(\frac{\pi(1+2k)}{a}, \frac{1}{3}\right), k \in \mathbb{Z}$

**Question 4**

For  $z \in \mathbb{C}$ , if  $\text{Im}(z) > 0$ , then  $\text{Arg}\left(\frac{z\bar{z}}{z-\bar{z}}\right)$  is

- A.  $-\frac{\pi}{2}$
- B. 0
- C.  $\frac{\pi}{4}$
- D.  $\frac{\pi}{2}$
- E.  $\pi$

**Question 5**

The graph of the circle given by  $|z - 2 - \sqrt{3}i| = 1$ , where  $z \in C$ , is shown below.

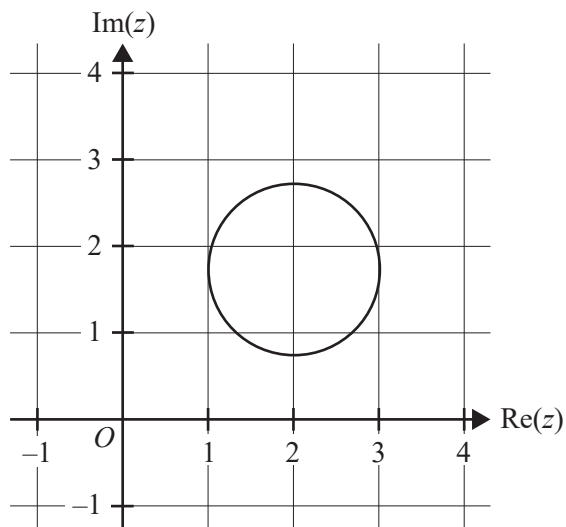

For points on this circle, the maximum value of  $|z|$  is

- A.  $\sqrt{3} + 1$
- B. 3
- C.  $\sqrt{13}$
- D.  $\sqrt{7} + 1$
- E. 8

**Question 6**

If  $z \in C$ ,  $z \neq 0$  and  $z^2 \in R$ , then the possible values of  $\arg(z)$  are

- A.  $\frac{k\pi}{2}, k \in Z$
- B.  $k\pi, k \in Z$
- C.  $\frac{(2k+1)\pi}{2}, k \in Z$
- D.  $\frac{(4k+1)\pi}{2}, k \in Z$
- E.  $\frac{(4k-1)\pi}{2}, k \in Z$

**Question 7**

A relation is defined parametrically by

$$x(t) = 5\cos(2t) + 1 \quad y(t) = 5\sin(2t) - 1$$

If  $A(6, -1)$  and  $B(1, 4)$  are two points that lie on the graph of the relation, then the shortest distance along the graph from  $A$  to  $B$  is

- A.  $\frac{\pi}{4}$
- B.  $\frac{\pi}{2}$
- C.  $\pi$
- D.  $\frac{5\pi}{4}$
- E.  $\frac{5\pi}{2}$

**Question 8**

Euler's method, with a step size of 0.1, is used to approximate the solution of the differential equation

$$\frac{dy}{dx} = y \sin(x).$$

Given that  $y = 2$  when  $x = 1$ , the value of  $y$ , correct to three decimal places, when  $x = 1.2$  is

- A. 2.168
- B. 2.178
- C. 2.362
- D. 2.370
- E. 2.381

**Question 9**

Which one of the following derivatives corresponds to a graph of  $f$  that has no points of inflection?

- A.  $f'(x) = 2(x - 3)^2 + 5$
- B.  $f'(x) = 2(x - 3)^3 + 5$
- C.  $f'(x) = \frac{5}{2}(x - 3)^2$
- D.  $f'(x) = \frac{1}{2}(x - 3)^2 - 5$
- E.  $f'(x) = (x - 3)^3 - 12x$

## Question 10

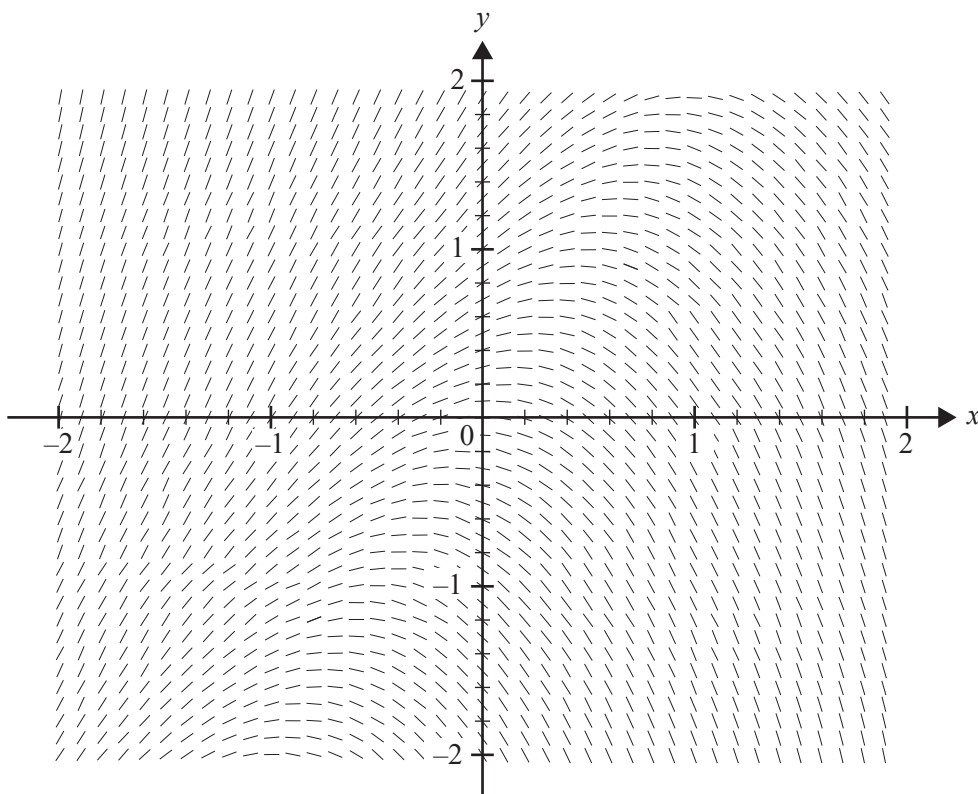

The differential equation that has the diagram above as its direction field is

- A.  $\frac{dy}{dx} = y + 2x$
- B.  $\frac{dy}{dx} = 2x - y$
- C.  $\frac{dy}{dx} = 2y - x$
- D.  $\frac{dy}{dx} = y - 2x$
- E.  $\frac{dy}{dx} = x + 2y$

**Question 11**

Let  $\hat{i}$  be a unit vector pointing east and let  $\hat{j}$  be a unit vector pointing north.

A group of hikers travels 5 km in the direction south  $30^\circ$  west and then north for 10 km.

The position vector  $\underline{a}$  of the group of hikers with respect to the starting point is

- A.  $\underline{a} = -\frac{5}{2}\hat{i} - \frac{5\sqrt{3}}{2}\hat{j}$
- B.  $\underline{a} = -\frac{5}{2}\hat{i} + \left(10 - \frac{5\sqrt{3}}{2}\right)\hat{j}$
- C.  $\underline{a} = -\frac{5}{2}\hat{i} + 10\hat{j}$
- D.  $\underline{a} = -\frac{5\sqrt{3}}{2}\hat{i} + \frac{15}{2}\hat{j}$
- E.  $\underline{a} = \frac{5}{2}\hat{i} + \left(10 + \frac{5\sqrt{3}}{2}\right)\hat{j}$

**Question 12**

Consider the vectors  $\underline{a} = x\hat{i} + \hat{j}$ ,  $\underline{b} = \hat{i} - \hat{j}$  and  $\underline{c} = \hat{i} + x\hat{j}$ .

Given that  $\theta$  is the angle between  $\underline{a}$  and  $\underline{b}$ , and  $\phi$  is the angle between  $\underline{b}$  and  $\underline{c}$ ,  $\cos(\theta)\cos(\phi)$  is

- A.  $\frac{2(1+x^2)}{1-x^2}$
- B.  $\frac{\sqrt{2}(1-x^2)}{1+x^2}$
- C.  $-\frac{(x+1)^2}{2(1+x^2)}$
- D.  $-\frac{(x-1)^2}{2(1+x^2)}$
- E.  $\frac{\sqrt{2}(1+x^2)}{1-x^2}$

**Question 13**

The scalar resolute of vector  $\underline{a}$  in the direction of vector  $\underline{b}$  is  $-4$ .

If  $\underline{b} = -\sqrt{3}\underline{i}$ , the vector resolute of  $\underline{a}$  in the direction of  $\underline{b}$  is

- A.  $-4\underline{i}$
- B.  $-3\underline{i}$
- C.  $\frac{1}{\sqrt{3}}\underline{i}$
- D.  $3\underline{i}$
- E.  $4\underline{i}$

**Question 14**

A body of mass 5 kg is acted on by a net force of magnitude  $F$  newtons. This force causes the body to move so that its velocity,  $v \text{ ms}^{-1}$ , along a straight line of motion is given by  $v = 3 + 2x$ , where  $x$  metres is the position of the body at time  $t$  seconds.

When  $x = 2$ ,  $F$  is equal to

- A. 10
- B. 14
- C. 35
- D. 70
- E. 175

**Question 15**

The diagram below shows a stationary body being acted on by four forces whose magnitudes are in newtons. The force of magnitude  $F_1$  newtons acts in the opposite direction to the force of magnitude 8 N.

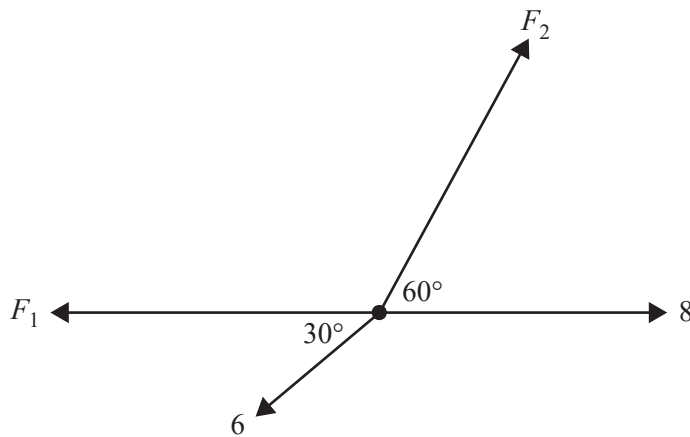

The value of  $F_1$  is

- A.  $8 - 2\sqrt{3}$
- B.  $2\sqrt{3}$
- C. 8
- D.  $8 + 2\sqrt{3}$
- E.  $8 - 3\sqrt{3}$



**Question 16**

An object of mass  $m$  kilograms slides down a smooth slope that is inclined at an angle of  $\theta^\circ$  to the horizontal, where  $0^\circ < \theta^\circ < 45^\circ$ . The acceleration of the object down the slope is  $a \text{ ms}^{-2}$ ,  $a > 0$ .

If the angle of inclination of the slope is doubled to  $2\theta^\circ$ , then the acceleration of the object down the slope, in  $\text{ms}^{-2}$ , is

- A.  $2a$
- B.  $\frac{2a}{g}\sqrt{g^2 - a^2}$
- C.  $\frac{2a^2 - g^2}{g}$
- D.  $\frac{a}{g}\sqrt{g^2 - a^2}$
- E.  $2a\sqrt{g^2 - a^2}$

**Question 17**

Bottles of a particular brand of soft drink are labelled as having a volume of 1.25 L. The machines filling the bottles deliver a volume that is normally distributed with a mean of 1.26 L and a standard deviation of 0.01 L.

The probability that six bottles have a mean volume that is at least the labelled volume of 1.25 L is closest to

- A. 0.5968
- B. 0.8413
- C. 0.9750
- D. 0.9772
- E. 0.9928

**Question 18**

A scientist investigates the distribution of the masses of fish in a particular river. A 95% confidence interval for the mean mass of a fish, in grams, calculated from a random sample of 100 fish is (70.2, 75.8).

The sample mean divided by the population standard deviation is closest to

- A. 1.3
- B. 2.6
- C. 5.1
- D. 10.2
- E. 13.0

**Question 19**

The mean unscaled score for a certain assessment task is 25 and the variance is 36. The scores are scaled so that the mean score is 30 and the variance is 49. Let  $S$  be the scaled scores, to the nearest integer, and let  $X$  be the unscaled scores.

If the scaling function takes the form  $S = mX + n$ , where  $m \in R^+$  and  $n \in R$ , then a score of 32 would be scaled to

- A. 22
- B. 34
- C. 36
- D. 38
- E. 40

**Question 20**

An office has two coffee machines that operate independently of each other. The time taken for each machine to produce a cup of coffee is normally distributed with a mean of 30 seconds and a standard deviation of 5 seconds. On a particular morning, a cup of coffee is produced from each machine.

The probability that the time taken by each coffee machine to produce one cup of coffee will differ by less than 3 seconds is closest to

- A. 0.164
- B. 0.236
- C. 0.329
- D. 0.451
- E. 0.671

**DO NOT WRITE IN THIS AREA**

**CONTINUES OVER PAGE**

**TURN OVER**

**SECTION B****Instructions for Section B**

Answer **all** questions in the spaces provided.

Unless otherwise specified, an **exact** answer is required to a question.

In questions where more than one mark is available, appropriate working **must** be shown.

Unless otherwise indicated, the diagrams in this book are **not** drawn to scale.

Take the **acceleration due to gravity** to have magnitude  $g \text{ ms}^{-2}$ , where  $g = 9.8$

**Question 1** (10 marks)

$$\text{Let } f(x) = \frac{(2x-3)(x+5)}{(x-1)(x+2)}.$$

- a. Express  $f(x)$  in the form  $A + \frac{Bx+C}{(x-1)(x+2)}$ , where  $A$ ,  $B$  and  $C$  are real constants. 1 mark

---

---

---

- b. State the equations of the asymptotes of the graph of  $f$ . 2 marks

---

---

- c. Sketch the graph of  $f$  on the set of axes below. Label the asymptotes with their equations, and label the maximum turning point and the point of inflection with their coordinates, correct to two decimal places. Label the intercepts with the coordinate axes.

3 marks

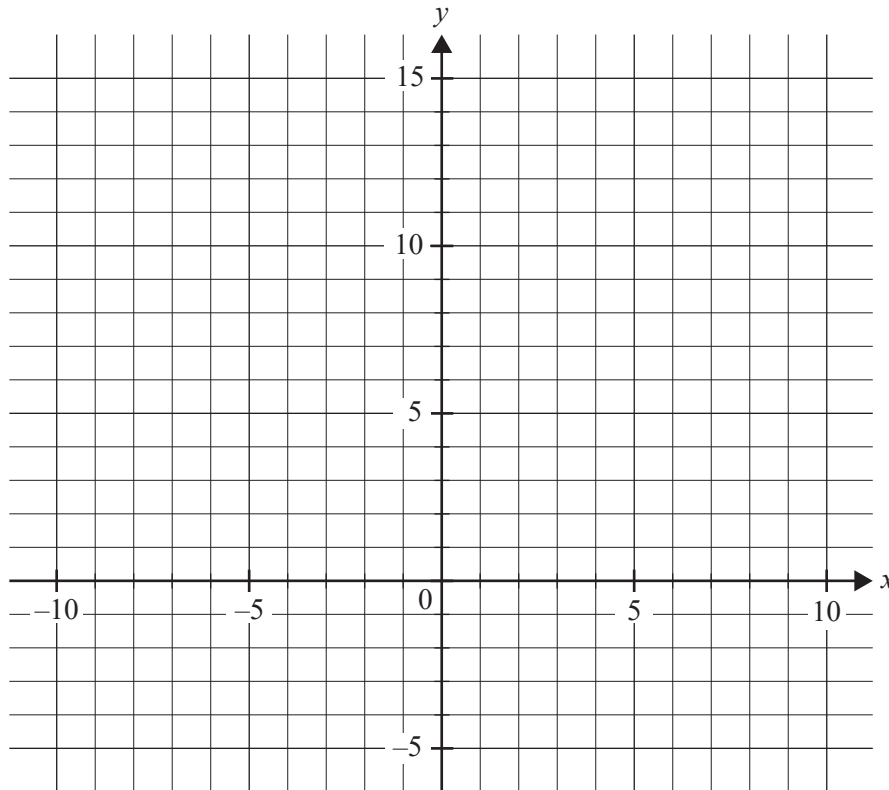

- d. Let  $g_k(x) = \frac{(2x-3)(x+5)}{(x-k)(x+2)}$ , where  $k$  is a real constant.

- i. For what values of  $k$  will the graph of  $g_k$  have two asymptotes?

2 marks

---



---

- ii. Given that the graph of  $g_k$  has more than two asymptotes, for what values of  $k$  will the graph of  $g_k$  have no stationary points?

2 marks

---



---

**Question 2** (9 marks)

The polynomial  $p(z) = z^3 + \alpha z^2 + \beta z + \gamma$ , where  $z \in C$  and  $\alpha, \beta, \gamma \in R$ , can also be written as  $p(z) = (z - z_1)(z - z_2)(z - z_3)$ , where  $z_1 \in R$  and  $z_2, z_3 \in C$ .

- a. i. State the relationship between  $z_2$  and  $z_3$ .

1 mark

---

---

- ii. Determine the values of  $\alpha, \beta$  and  $\gamma$ , given that  $p(2) = -13$ ,  $|z_2 + z_3| = 0$  and  $|z_2 - z_3| = 6$ .

3 marks

---

---

---

---

---

---

---

---

DO NOT WRITE IN THIS AREA

Consider the point  $z_4 = \sqrt{3} + i$ .

b. Sketch the ray given by  $\text{Arg}(z - z_4) = \frac{5\pi}{6}$  on the Argand diagram below.

2 marks

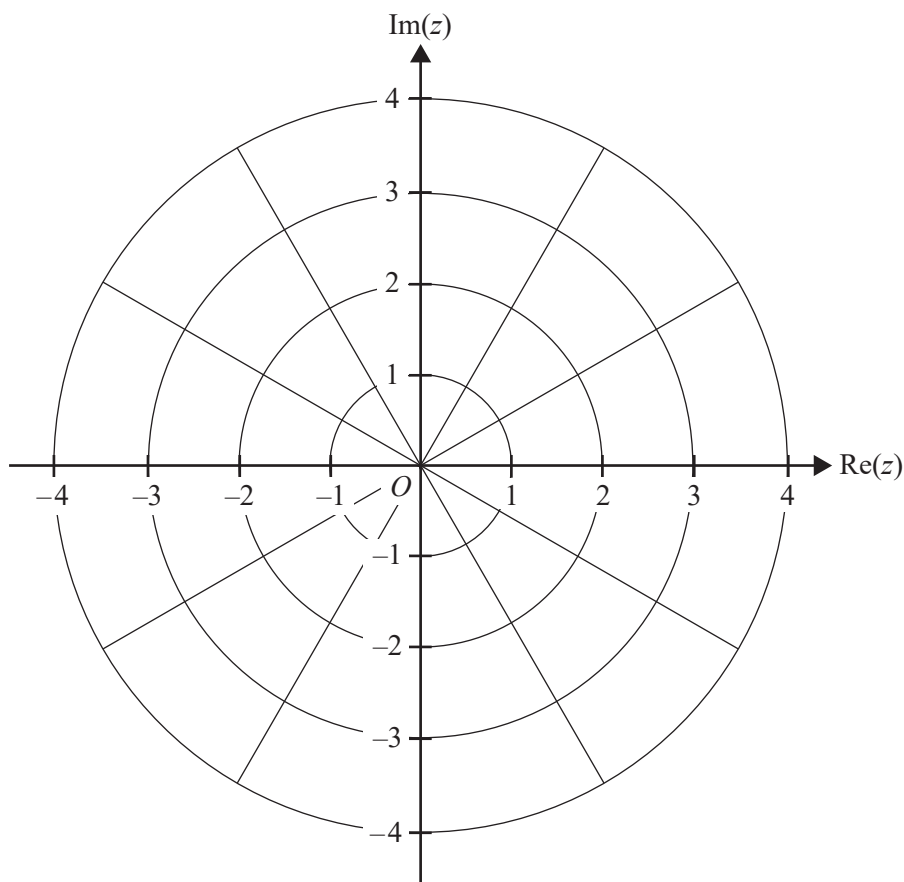

c. The ray  $\text{Arg}(z - z_4) = \frac{5\pi}{6}$  intersects the circle  $|z - 3i| = 1$ , dividing it into a major and a minor segment.

i. Sketch the circle  $|z - 3i| = 1$  on the Argand diagram in **part b**.

1 mark

ii. Find the area of the minor segment.

2 marks

---



---



---



---



---



---

**Question 3** (10 marks)

A thin-walled vessel is produced by rotating the graph of  $y = x^3 - 8$  about the  $y$ -axis for  $0 \leq y \leq H$ . All lengths are measured in centimetres.

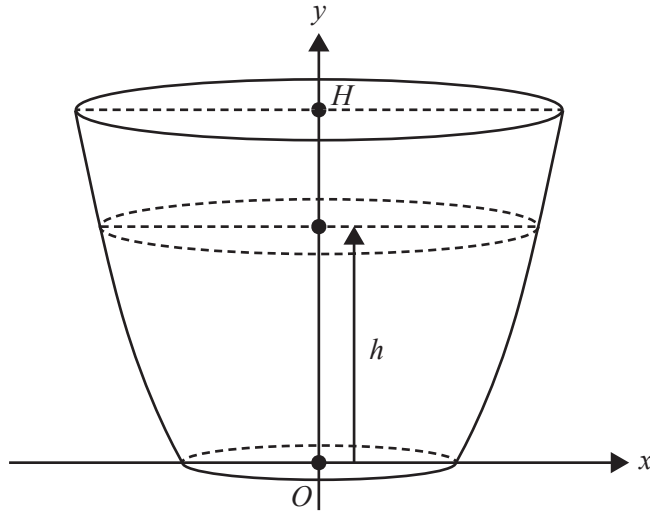

- a. i. Write down a definite integral in terms of  $y$  and  $H$  for the volume of the vessel in cubic centimetres.

1 mark

---



---



---

- ii. Hence, find an expression for the volume of the vessel in terms of  $H$ .

1 mark

---



---



---



Water is poured into the vessel. However, due to a crack in the base, water leaks out at a rate proportional to the square root of the depth  $h$  of water in the vessel, that is  $\frac{dV}{dt} = -4\sqrt{h}$ , where  $V$  is the volume of water remaining in the vessel, in cubic centimetres, after  $t$  minutes.

- b. i.** Show that  $\frac{dh}{dt} = \frac{-4\sqrt{h}}{\pi(h+8)^{\frac{2}{3}}}$ . 2 marks

---



---



---



---



---



---

- ii.** Find the maximum rate, in centimetres per minute, at which the depth of water in the vessel decreases, correct to two decimal places, and find the corresponding depth in centimetres. 2 marks

---



---



---



---

- iii.** Let  $H = 50$  for a particular vessel. The vessel is initially full and water continues to leak out at a rate of  $4\sqrt{h} \text{ cm}^3 \text{ min}^{-1}$ .  
Find the maximum rate at which water can be added, in cubic centimetres per minute, without the vessel overflowing. 1 mark

---



---



---

- c. The vessel is initially full where  $H = 50$  and water leaks out at a rate of  $4\sqrt{h}$   $\text{cm}^3 \text{min}^{-1}$ . When the depth of the water drops to 25 cm, extra water is poured in at a rate of  $40\sqrt{2}$   $\text{cm}^3 \text{min}^{-1}$ .

Find how long it takes for the vessel to refill completely from a depth of 25 cm. Give your answer in minutes, correct to one decimal place.

3 marks

---

---

---

---

---

---

DO NOT WRITE IN THIS AREA

DO NOT WRITE IN THIS AREA

**CONTINUES OVER PAGE**

**SECTION B – continued**  
**TURN OVER**

**Question 4** (11 marks)

A car that performs stunts moves along a track, as shown in the diagram below. The car accelerates from rest at point  $A$ , is launched into the air by the ramp  $BO$  and lands on a second section of track at or beyond point  $C$ . This second section of track is inclined at  $10^\circ$  to the horizontal.

Due to a tailwind, the effect of air resistance is negligible. Point  $O$  is taken as the origin of a cartesian coordinate system and all displacements are measured in metres. Point  $C$  has the coordinates  $(16, 4)$ .

At point  $O$ , the speed of the car is  $u \text{ ms}^{-1}$  and it takes off at an angle of  $\theta$  to the horizontal direction. After the car passes point  $O$ , it follows a trajectory where the position of the car's rear wheels relative to point  $O$ , at time  $t$  seconds after passing point  $O$ , is given by

$\mathbf{r}(t) = ut \cos(\theta) \mathbf{i} + \left( ut \sin(\theta) - \frac{1}{2}gt^2 \right) \mathbf{j}$  until the car lands on the second section of track that starts at point  $C$ .

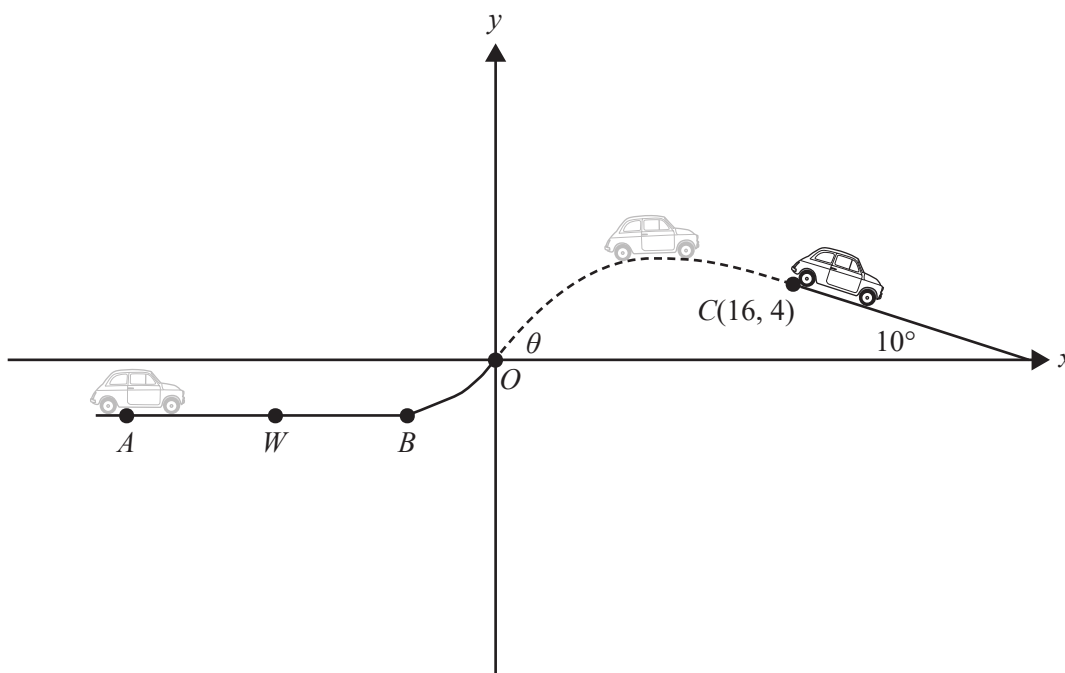

- a. Show that the path of the rear wheels of the car, while in the air, is given in cartesian form by

$$y = x \tan(\theta) - \frac{4.9x^2}{u^2 \cos^2(\theta)}.$$

1 mark

---



---



---



---



---



---

- b. If  $\theta = 30^\circ$ , find the minimum speed, in  $\text{ms}^{-1}$ , that the car must reach at point  $O$  for the rear wheels to land on the second section of track at or beyond point  $C$ . Give your answer correct to two decimal places.

2 marks

---



---



---



---



---

- c. The ramp  $BO$  is constructed so that the angle  $\theta$  can be varied.

For what values of  $\theta$  and  $u$  will the path of the rear wheels of the car join up **smoothly** with the beginning of the second section of track at point  $C$ ? Give your answer for  $\theta$  in degrees, correct to the nearest degree, and give your answer for  $u$  in  $\text{ms}^{-1}$ , correct to one decimal place. 3 marks

---



---



---



---



---



---



---

The car accelerates from rest along the horizontal section of track  $AB$ , where its acceleration,  $a \text{ ms}^{-2}$ , after it has travelled  $s$  metres from point  $A$ , is given by  $a = \frac{60}{v}$ , where  $v$  is its speed at  $s$  metres.

- d. Show that  $v$  in terms of  $s$  is given by  $v = (180s)^{\frac{1}{3}}$ .

2 marks

---



---



---



---



---



---



---

- e. After the car leaves point  $A$ , it accelerates to reach a speed of  $20 \text{ ms}^{-1}$  at point  $B$ . However, if the stunt is called off, the car immediately brakes and reduces its speed at a rate of  $9 \text{ ms}^{-2}$ . It is only safe to call off the stunt if the car can come to rest at or before point  $B$ . Point  $W$  is the furthest point along the section  $AB$  at which the stunt can be called off.

How far is point  $W$  from point  $B$ ? Give your answer in metres, correct to one decimal place. 3 marks

---

---

---

---

---

---

---

---

---

---

DO NOT WRITE IN THIS AREA

DO NOT WRITE IN THIS AREA

**CONTINUES OVER PAGE**

**SECTION B – continued**  
**TURN OVER**

**Question 5** (10 marks)

A mass of  $m_1$  kilograms is placed on a plane inclined at  $30^\circ$  to the horizontal. It is connected by a light inextensible string to a second mass of  $m_2$  kilograms that hangs below a frictionless pulley situated at the top end of the incline, over which the string passes.

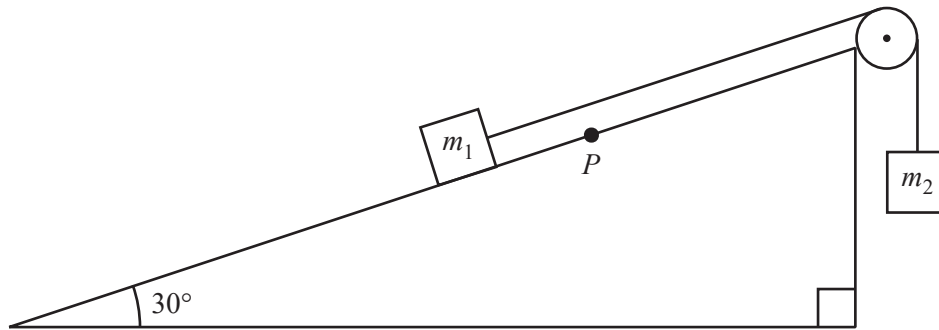

- a. Given that the inclined plane is smooth, find the relationship between  $m_1$  and  $m_2$  if the mass  $m_1$  moves down the plane at constant speed.

2 marks

---



---



---



---



---

The masses are now placed on a **rough** plane inclined at  $30^\circ$ , with the light inextensible string passing over a frictionless pulley in the same way, as shown in the diagram above. Let  $N$  be the magnitude of the normal force exerted on the mass  $m_1$  by the plane. A resistance force of magnitude  $\lambda N$  acts on and opposes the motion of the mass  $m_1$ .

- b. The mass  $m_1$  moves up the plane.

- i. Mark and label all forces acting on this mass on the diagram above.

1 mark

- ii. Taking the direction up the plane as positive, find the acceleration of the mass  $m_1$  in terms of  $m_1$ ,  $m_2$  and  $\lambda$ .

2 marks

---



---



---



---



---



Some time after the masses have begun to move, the mass  $m_2$  hits the ground at  $4.5 \text{ ms}^{-1}$  and the string becomes slack. At this instant, the mass  $m_1$  is at the point  $P$  on the plane, which is 2 m from the pulley. Take the value of  $\lambda$  to be 0.1

- c. How far from point  $P$  does the mass  $m_1$  travel before it starts to slide back down the plane?  
Give your answer in metres, correct to two decimal places. 2 marks

---

---

---

---

---

- d. Find the time taken, from when the string becomes slack, for the mass  $m_1$  to return to point  $P$ .  
Give your answer correct to the nearest tenth of a second. 3 marks

---

---

---

---

---

DO NOT WRITE IN THIS AREA

**Question 6** (10 marks)

The maximum load of a lift in a chocolate company's office building is 1000 kg. The masses of the employees who use the lift are normally distributed with a mean of 75 kg and a standard deviation of 8 kg. On a particular morning there are  $n$  employees about to use the lift.

- a. What is the maximum possible value of  $n$  for there to be less than a 1% chance of the lift exceeding the maximum load?

2 marks

---

---

---

Clare, who is one of the employees, likes to have a hot drink after she exits the lift. The time taken for the drink machine to dispense a hot drink is normally distributed with a mean of 2 minutes and a standard deviation of 0.5 minutes. Times taken to dispense successive hot drinks are independent.

- b. Clare has a meeting at 9.00 am and at 8.52 am she is fourth in the queue for a hot drink. Assume that the waiting time between hot drinks dispensed is negligible and that it takes Clare 0.5 minutes to get from the drink machine to the meeting room.

What is the probability, correct to four decimal places, that Clare will get to her meeting on time?

2 marks

---

---

---

Clare is a statistician for the chocolate company. The number of chocolate bars sold daily is normally distributed with a mean of 60 000 and a standard deviation of 5000. To increase sales, the company decides to run an advertising campaign. After the campaign, the mean daily sales from 14 randomly selected days was found to be 63 500.

Clare has been asked to investigate whether the advertising campaign was effective, so she decides to perform a one-sided statistical test at the 1% level of significance.

- c. i. Write down suitable null and alternative hypotheses for this test. 1 mark

---



---

- ii. Determine the  $p$  value, correct to four decimal places, for this test. 1 mark

---



---

- iii. Giving a reason, state whether there is any evidence for the success of the advertising campaign. 1 mark

---



---

- d. Find the range of values for the mean daily sales of another 14 randomly selected days that would lead to the null hypothesis being rejected when tested at the 1% level of significance. Give your answer correct to the nearest integer. 1 mark

---



---



---



---

- e. The advertising campaign has been successful to the extent that the mean daily sales is now 63 000.

A statistical test is applied at the 5% level of significance.

Find the probability that the null hypothesis would be incorrectly accepted, based on the sales of another 14 randomly selected days and assuming a standard deviation of 5000. Give your answer correct to three decimal places. 2 marks

---



---



---



---



**Victorian Certificate of Education  
2021**

**SPECIALIST MATHEMATICS**

**Written examination 2**

**FORMULA SHEET**

**Instructions**

This formula sheet is provided for your reference.  
A question and answer book is provided with this formula sheet.

**Students are NOT permitted to bring mobile phones and/or any other unauthorised electronic devices into the examination room.**

## Specialist Mathematics formulas

### Mensuration

area of a trapezium	$\frac{1}{2}(a+b)h$
curved surface area of a cylinder	$2\pi rh$
volume of a cylinder	$\pi r^2 h$
volume of a cone	$\frac{1}{3}\pi r^2 h$
volume of a pyramid	$\frac{1}{3}Ah$
volume of a sphere	$\frac{4}{3}\pi r^3$
area of a triangle	$\frac{1}{2}bc \sin(A)$
sine rule	$\frac{a}{\sin(A)} = \frac{b}{\sin(B)} = \frac{c}{\sin(C)}$
cosine rule	$c^2 = a^2 + b^2 - 2ab \cos(C)$

### Circular functions

$\cos^2(x) + \sin^2(x) = 1$	
$1 + \tan^2(x) = \sec^2(x)$	$\cot^2(x) + 1 = \operatorname{cosec}^2(x)$
$\sin(x+y) = \sin(x)\cos(y) + \cos(x)\sin(y)$	$\sin(x-y) = \sin(x)\cos(y) - \cos(x)\sin(y)$
$\cos(x+y) = \cos(x)\cos(y) - \sin(x)\sin(y)$	$\cos(x-y) = \cos(x)\cos(y) + \sin(x)\sin(y)$
$\tan(x+y) = \frac{\tan(x) + \tan(y)}{1 - \tan(x)\tan(y)}$	$\tan(x-y) = \frac{\tan(x) - \tan(y)}{1 + \tan(x)\tan(y)}$
$\cos(2x) = \cos^2(x) - \sin^2(x) = 2\cos^2(x) - 1 = 1 - 2\sin^2(x)$	
$\sin(2x) = 2\sin(x)\cos(x)$	$\tan(2x) = \frac{2\tan(x)}{1 - \tan^2(x)}$

**Circular functions – continued**

<b>Function</b>	$\sin^{-1}$ or arcsin	$\cos^{-1}$ or arccos	$\tan^{-1}$ or arctan
<b>Domain</b>	$[-1, 1]$	$[-1, 1]$	$R$
<b>Range</b>	$\left[-\frac{\pi}{2}, \frac{\pi}{2}\right]$	$[0, \pi]$	$\left(-\frac{\pi}{2}, \frac{\pi}{2}\right)$

**Algebra (complex numbers)**

$z = x + iy = r(\cos(\theta) + i\sin(\theta)) = r \operatorname{cis}(\theta)$	
$ z  = \sqrt{x^2 + y^2} = r$	$-\pi < \operatorname{Arg}(z) \leq \pi$
$z_1 z_2 = r_1 r_2 \operatorname{cis}(\theta_1 + \theta_2)$	$\frac{z_1}{z_2} = \frac{r_1}{r_2} \operatorname{cis}(\theta_1 - \theta_2)$
$z^n = r^n \operatorname{cis}(n\theta)$ (de Moivre's theorem)	

**Probability and statistics**

for random variables $X$ and $Y$	$E(aX + b) = aE(X) + b$ $E(aX + bY) = aE(X) + bE(Y)$ $\operatorname{var}(aX + b) = a^2 \operatorname{var}(X)$
for independent random variables $X$ and $Y$	$\operatorname{var}(aX + bY) = a^2 \operatorname{var}(X) + b^2 \operatorname{var}(Y)$
approximate confidence interval for $\mu$	$\left(\bar{x} - z \frac{s}{\sqrt{n}}, \bar{x} + z \frac{s}{\sqrt{n}}\right)$
distribution of sample mean $\bar{X}$	mean $E(\bar{X}) = \mu$ variance $\operatorname{var}(\bar{X}) = \frac{\sigma^2}{n}$

**Calculus**

$\frac{d}{dx}(x^n) = nx^{n-1}$	$\int x^n dx = \frac{1}{n+1} x^{n+1} + c, n \neq -1$
$\frac{d}{dx}(e^{ax}) = ae^{ax}$	$\int e^{ax} dx = \frac{1}{a} e^{ax} + c$
$\frac{d}{dx}(\log_e(x)) = \frac{1}{x}$	$\int \frac{1}{x} dx = \log_e x  + c$
$\frac{d}{dx}(\sin(ax)) = a \cos(ax)$	$\int \sin(ax) dx = -\frac{1}{a} \cos(ax) + c$
$\frac{d}{dx}(\cos(ax)) = -a \sin(ax)$	$\int \cos(ax) dx = \frac{1}{a} \sin(ax) + c$
$\frac{d}{dx}(\tan(ax)) = a \sec^2(ax)$	$\int \sec^2(ax) dx = \frac{1}{a} \tan(ax) + c$
$\frac{d}{dx}(\sin^{-1}(x)) = \frac{1}{\sqrt{1-x^2}}$	$\int \frac{1}{\sqrt{a^2-x^2}} dx = \sin^{-1}\left(\frac{x}{a}\right) + c, a > 0$
$\frac{d}{dx}(\cos^{-1}(x)) = \frac{-1}{\sqrt{1-x^2}}$	$\int \frac{-1}{\sqrt{a^2-x^2}} dx = \cos^{-1}\left(\frac{x}{a}\right) + c, a > 0$
$\frac{d}{dx}(\tan^{-1}(x)) = \frac{1}{1+x^2}$	$\int \frac{a}{a^2+x^2} dx = \tan^{-1}\left(\frac{x}{a}\right) + c$
	$\int (ax+b)^n dx = \frac{1}{a(n+1)} (ax+b)^{n+1} + c, n \neq -1$
	$\int (ax+b)^{-1} dx = \frac{1}{a} \log_e ax+b  + c$
product rule	$\frac{d}{dx}(uv) = u \frac{dv}{dx} + v \frac{du}{dx}$
quotient rule	$\frac{d}{dx}\left(\frac{u}{v}\right) = \frac{v \frac{du}{dx} - u \frac{dv}{dx}}{v^2}$
chain rule	$\frac{dy}{dx} = \frac{dy}{du} \frac{du}{dx}$
Euler's method	If $\frac{dy}{dx} = f(x)$ , $x_0 = a$ and $y_0 = b$ , then $x_{n+1} = x_n + h$ and $y_{n+1} = y_n + hf(x_n)$
acceleration	$a = \frac{d^2x}{dt^2} = \frac{dv}{dt} = v \frac{dv}{dx} = \frac{d}{dx}\left(\frac{1}{2}v^2\right)$
arc length	$\int_{x_1}^{x_2} \sqrt{1+(f'(x))^2} dx$ or $\int_{t_1}^{t_2} \sqrt{(x'(t))^2 + (y'(t))^2} dt$

**Vectors in two and three dimensions**

$\underline{r} = x\hat{i} + y\hat{j} + z\hat{k}$
$ \underline{r}  = \sqrt{x^2 + y^2 + z^2} = r$
$\dot{\underline{r}} = \frac{d\underline{r}}{dt} = \frac{dx}{dt}\hat{i} + \frac{dy}{dt}\hat{j} + \frac{dz}{dt}\hat{k}$
$\underline{r}_1 \cdot \underline{r}_2 = r_1 r_2 \cos(\theta) = x_1 x_2 + y_1 y_2 + z_1 z_2$

**Mechanics**

momentum	$\underline{p} = m\underline{v}$
equation of motion	$\underline{R} = m\underline{a}$