

**THE  
HEFFERNAN  
GROUP**

P.O. Box 480  
Deepdene Delivery Centre 3103  
ABN 20 607 374 020  
Phone 9836 5021  
Fax 9836 5025

Student Name: \_\_\_\_\_

## **SPECIALIST MATHEMATICS**

### **TRIAL EXAMINATION 1**

#### **(FACTS, SKILLS AND APPLICATIONS TASK)**

**2002**

Reading Time: 15 minutes

Writing time: 90 minutes

#### **Instructions to students**

This exam consists of Part I and Part II.

Part I consists of 30 multiple-choice questions and should be answered on the detachable answer sheet on page 26 of this exam. This section of the paper is worth 30 marks.

Part II consists of 6 short-answer questions, all of which should be answered in the spaces provided. Part II begins on page 17 of this exam. This section of the paper is worth 20 marks.

There is a total of 50 marks available.

The acceleration due to gravity should be taken to have magnitude  $g \text{ m/s}^2$  where  $g = 9.8$

Students may bring up to two A4 pages of pre-written notes into the exam.

Formula sheets can be found on pages 23–25 of this exam.

*This paper has been prepared independently of the Victorian Curriculum and Assessment Authority to provide additional exam preparation for students. Although references have been reproduced with permission of the Victorian Curriculum and Assessment Authority the publication is in no way connected with or endorsed by the Victorian Curriculum and Assessment Authority.*

© THE HEFFERNAN GROUP 2002

This Trial Exam is licensed on a non transferable basis to the purchaser. It may be copied for educational use within the school which has purchased it. This license does not permit distribution or copying of this Trial Exam outside that school or by any individual purchaser.

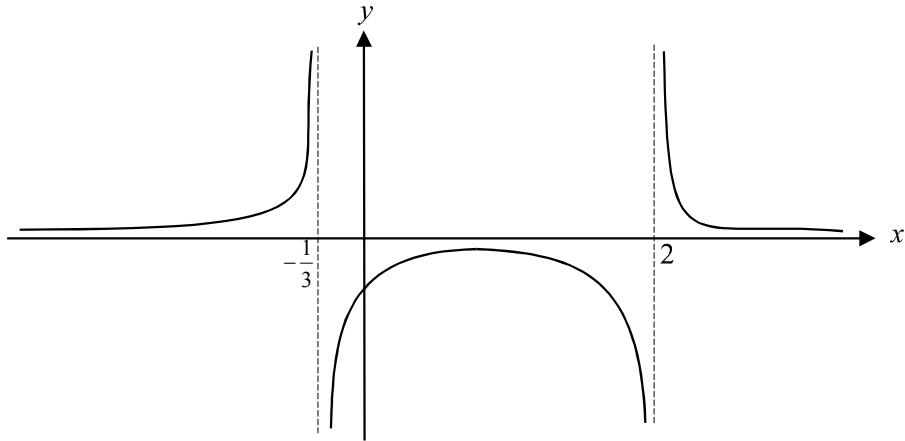
**PART I****Question 1**

The equation for the graph shown above could be

- A.  $y = \frac{1}{3x^2 - 7x + 2}$
- B.  $y = \frac{1}{3x^2 - 5x - 2}$
- C.  $y = \frac{1}{3x - 1} - \frac{1}{x + 2}$
- D.  $y = \frac{1}{3x + 1} + \frac{1}{x - 2}$
- E.  $y = \frac{1}{x - \frac{1}{3}} + \frac{1}{x - 2}$

## Question 2

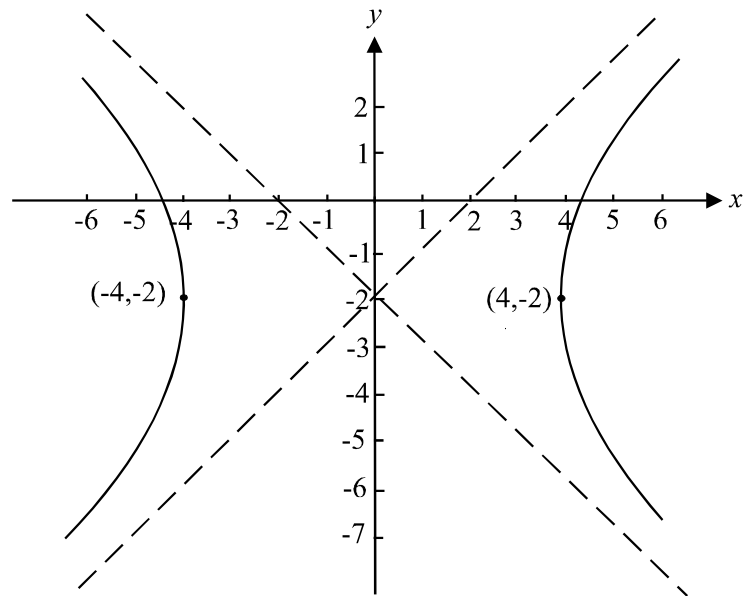

The equation for the graph shown is

- A.  $\frac{x^2}{4} - (y - 2)^2 = 1$
- B.  $x^2 - \frac{(y - 2)^2}{4} = 1$
- C.  $\frac{x^2}{16} - \frac{(y + 2)^2}{4} = 1$
- D.  $\frac{x^2}{16} - \frac{(y - 2)^2}{16} = 1$
- E.  $\frac{x^2}{16} - \frac{(y + 2)^2}{16} = 1$

**Question 3**

If  $\cot \theta = -\frac{1}{4}$  and  $\frac{\pi}{2} < \theta < \pi$  then  $\sin 2\theta$  is equal to

- A.  $\frac{4}{\sqrt{15}}$
- B.  $\frac{-8}{15}$
- C.  $\frac{4}{\sqrt{17}}$
- D.  $\frac{-8}{17}$
- E.  $\frac{8}{17}$

**Question 4**

If  $y = \text{Sin}^{-1}\left(\frac{1}{x^2}\right)$  and  $x \geq 1$  then  $\frac{dy}{dx}$  is equal to

- A.  $\frac{-2x}{\sqrt{x^4 - 1}}$
- B.  $\frac{2x}{\sqrt{x^4 - 1}}$
- C.  $\frac{-2}{x\sqrt{x^4 - 1}}$
- D.  $\frac{2}{x\sqrt{x^4 - 1}}$
- E.  $\frac{-2}{x^3\sqrt{1 - x^2}}$

**Question 5**

If  $u = 2 + 3i$  and  $v = 1 - 2i$  then  $\frac{u}{v}$  is equal to

- A.  $\frac{-4}{13} - \frac{7}{13}i$
- B.  $\frac{-4}{5} + \frac{7}{5}i$
- C.  $\frac{1}{2} - \frac{2}{3}i$
- D.  $\frac{8}{5} - \frac{1}{5}i$
- E.  $2 - \frac{3}{2}i$

**Question 6**

The effect of multiplying a complex number by  $i^3$  is to

- A. translate it 1 unit downwards
- B. reflect it in the line  $y = i^3$
- C. reflect it in the imaginary axis
- D. rotate it through an angle of  $\frac{\pi}{2}$  anticlockwise about the origin
- E. rotate it through an angle of  $\frac{3\pi}{2}$  anticlockwise about the origin.

**Question 7**

The polar form of the complex number  $a + ai$ , where  $a$  is a positive or negative whole number could not be

- A.  $\sqrt{2}\text{cis}\left(\frac{\pi}{4}\right)$
- B.  $2\text{cis}\left(\frac{\pi}{4}\right)$
- C.  $\sqrt{2}\text{cis}\left(\frac{5\pi}{4}\right)$
- D.  $2\sqrt{2}\text{cis}\left(\frac{5\pi}{4}\right)$
- E.  $10\sqrt{2}\text{cis}\left(\frac{\pi}{4}\right)$

**Question 8**

If  $1 + 2i$  is a solution to the equation  $z^3 + az^2 + bz - 10 = 0$  where  $a, b \in R$ , then

- A.  $a = -4$  and  $b = 9$
- B.  $a = 0$  and  $b = 1$
- C.  $a = 1$  and  $b = 2$
- D.  $a = 1$  and  $b = -2$
- E.  $a = 5$  and  $b = -3$

**Question 9**

Which one of the following shows the region of the complex plane described by  $\{z : |z - i| \leq 2\} \cap \{z : \text{Im}(z) - \text{Re}(z) \geq 1\}$ ?

**A.**

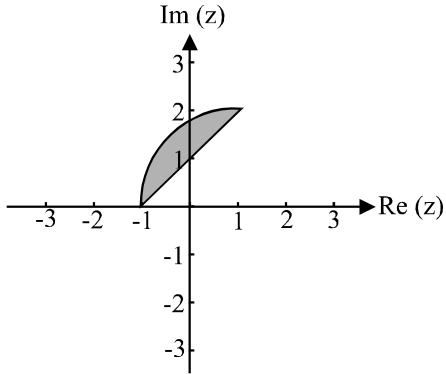

**B.**

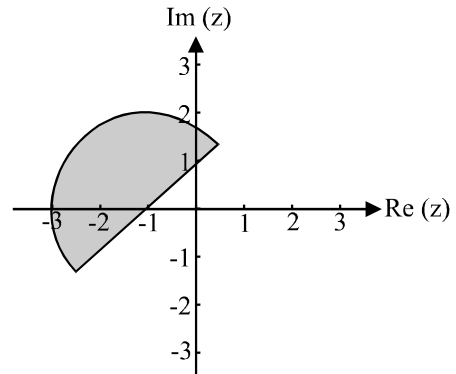

**C.**

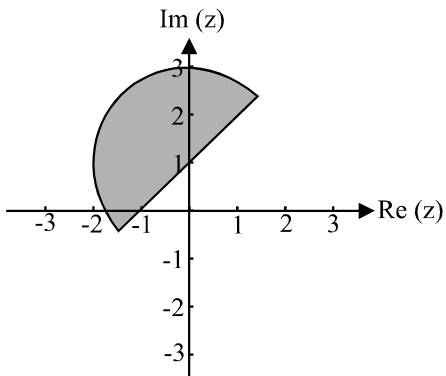

**D.**

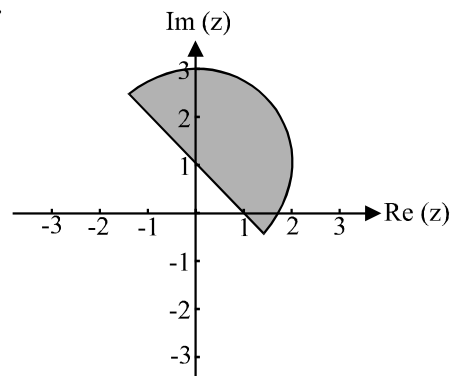

**E.**

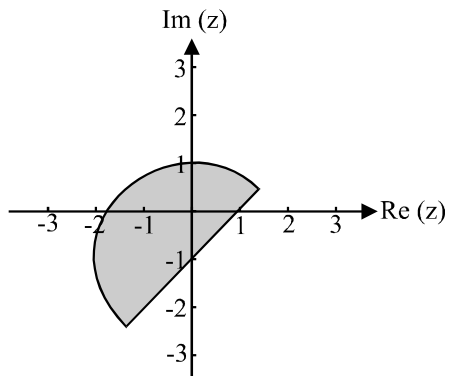

**Question 10**

An antiderivative of  $e^{2x}\sqrt{(e^x-1)(e^x+1)}$  is

- A.  $\frac{1}{4\sqrt{e^{2x}-1}}$   
 B.  $\frac{1}{3}(e^{2x}-1)^{\frac{3}{2}}$   
 C.  $\frac{1}{2}(e^{2x}-1)^{\frac{3}{2}}$   
 D.  $e^{3x}(e^{2x}+1)$   
 E.  $e^{2x}\sqrt{e^{2x}-2}$

**Question 11**

$\int \sin 2x \cos^2 x dx$  is equal to

- A.  $-\frac{\cos^4 x}{2} + c$   
 B.  $\frac{\cos^4 x}{2} + c$   
 C.  $-6 \cos^2 x + c$   
 D.  $-\frac{\cos 2x \cos^3 x}{6} + c$   
 E.  $-\frac{\cos 2x \sin^3 x}{6} + c$

**Question 12**

$\int_0^{\sqrt{7}} \frac{5}{\sqrt{7-x^2}} dx$  is equal to

- A.  $\frac{-5\pi}{2}$   
 B.  $\frac{\pi}{2}$   
 C.  $\frac{5\pi}{2}$   
 D.  $5\pi$   
 E.  $5 \log_e \sqrt{7}$

**Question 13**

If  $h'(x) = \frac{\sqrt{\log_e(5x)}}{2x}$  and  $h\left(\frac{1}{5}\right) = 0$  then  $h(x)$  is equal to

- A.  $\frac{1}{4\sqrt{\log_e(5x)}}$
- B.  $\log_e \sqrt{5x} + 1$
- C.  $\frac{2}{5} \log_e(5x)$
- D.  $\frac{1}{3} (\log_e(5x))^{\frac{3}{2}}$
- E.  $\frac{1}{3} \log_e(5x) + 1$



## Question 14

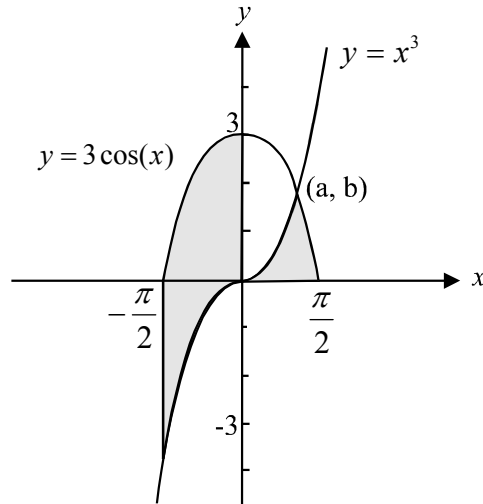

The diagram shows the graph of  $y = x^3$ ,  $x \in R$  and  $y = 3 \cos(x)$ ,  $-\frac{\pi}{2} \leq x \leq \frac{\pi}{2}$ .

The graphs intersect at the point  $(a, b)$ .

The total area of the shaded regions shown above is given by

- A.  $\int_0^{\frac{\pi}{2}} (x^3 - 3 \cos(x)) dx + \int_{-\frac{\pi}{2}}^0 (3 \cos(x) - x^3) dx$
- B.  $\int_a^{\frac{\pi}{2}} (x^3 - 3 \cos(x)) dx - \int_{\frac{\pi}{2}}^0 (3 \cos(x) - x^3) dx$
- C.  $\int_{\frac{\pi}{2}}^b (x^3 - 3 \cos(x)) dx - \int_{-\frac{\pi}{2}}^0 (3 \cos(x) - x^3) dx$
- D.  $\int_b^{\frac{\pi}{2}} 3 \cos(x) dx + \int_0^b x^3 dx + \int_{-\frac{\pi}{2}}^0 (3 \cos(x) - x^3) dx$
- E.  $\int_a^{\frac{\pi}{2}} 3 \cos(x) dx + \int_0^a x^3 dx + \int_{-\frac{\pi}{2}}^0 (3 \cos(x) - x^3) dx$

## Question 15

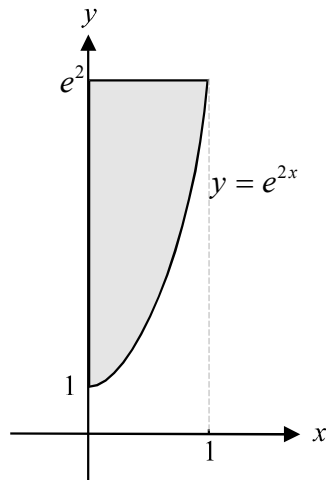

In the diagram above, the shaded region is the region enclosed by the graph of  $y = e^{2x}$ , the  $y$ -axis and the line with equation  $y = e^2$ . This region is rotated about the  $y$ -axis to form a solid of revolution. The volume of this solid in cubic units, is given by

- A.  $\pi \int_1^{e^2} e^{4x} dy$
- B.  $\pi \int_0^1 e^{4x} dy$
- C.  $\pi \int_1^{e^2} \log_e(2y) dy$
- D.  $\frac{\pi}{2} \int \log_e y dy$
- E.  $\pi \int_1^{e^2} (\log_e \sqrt{y})^2 dy$

**Question 16**

The equation  $y = \log_e(\cot \theta)$ ,  $0 < \theta < \frac{\pi}{2}$ , is a solution to which one of the following differential equations?

- A.  $\frac{dy}{d\theta} - \frac{1}{\sin \theta \cos \theta} = 0$
- B.  $\frac{dy}{d\theta} = \cos \theta + \cot \theta$
- C.  $\frac{d^2y}{d\theta^2} + \frac{1}{\sin \theta \cos \theta} = 0$
- D.  $\frac{d^2y}{d\theta^2} + \tan \theta = \cot \theta$
- E.  $\frac{d^2y}{d\theta^2} - \frac{dy}{d\theta} = \frac{\cos^2 \theta - \sin^2 \theta}{\sin^2 \theta \cos^2 \theta} + \frac{1}{\sin \theta \cos \theta}$

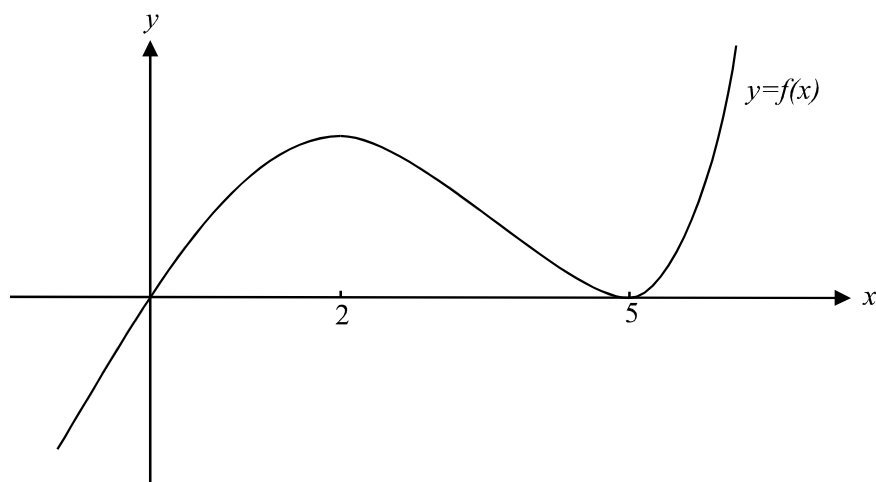
**Question 17**

The graph of  $y = f(x)$  is shown above. From this graph we know that

- A.  $f(0) = 0$ ,  $f(0) = 2$  and  $f'(2) = 0$
- B.  $f(2) = 0$ ,  $f'(2) = 0$  and  $f'(5) = 0$
- C.  $f(5) = 0$ ,  $f'(0) = 0$  and  $f'(2) = 0$
- D.  $f(0) = 0$ ,  $f'(2) = 0$  and  $f''(5) > 0$
- E.  $f(0) = 0$ ,  $f(5) = 0$  and  $f''(2) > 0$

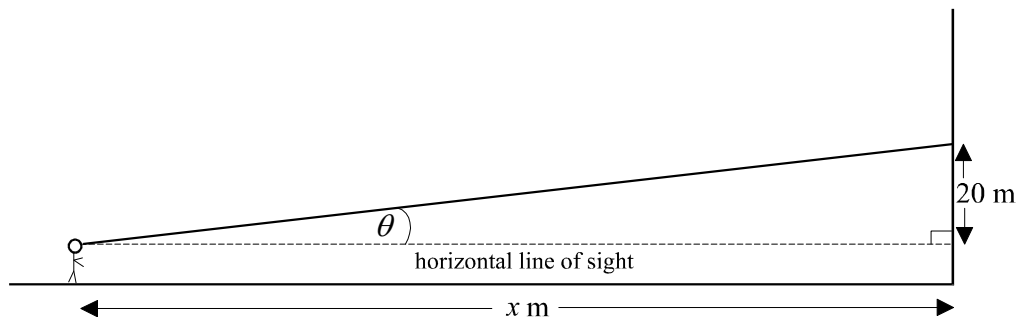
**Question 18**

A man is walking along a horizontal footpath towards a tall building. As he walks, he stares at a window in the building, which is 20m and  $\theta$  radians, above his horizontal line of sight. The man is walking at 2m/sec. The rate at which  $\theta$  is changing,  $\frac{d\theta}{dt}$ , as the man approaches the building is given by

- A.  $\frac{-20}{\sin^2 \theta}$
- B.  $\frac{20}{\sin^2 \theta}$
- C.  $\frac{20}{\tan \theta}$
- D.  $\frac{-\sin^2 \theta}{10}$
- E.  $\frac{\sin^2 \theta}{10}$

**Question 19**

The differential equation  $\frac{dy}{dx} = \sqrt{4 - x^2}$  with  $y = 0$  at  $x = 1$  is solved using Eulers method with a step size of 0.1. The value obtained for  $y$  at  $x = 1.2$ , is closest to

- A. 0.1732
- B. 0.3402
- C. 1.2
- D. 1.3402
- E. 1.462

**Question 20**

A particle starts from rest at an origin and moves in a straight line with an acceleration of  $v(v+1) \text{ m/sec}^2$ . The velocity of the particle when its displacement is  $x$  metres is given by

- A.  $\frac{v^4}{12} + \frac{v^3}{6}$   
 B.  $\log_e(v+1)$   
 C.  $\frac{2x}{x+2}$   
 D.  $1 - e^x$   
 E.  $e^x - 1$

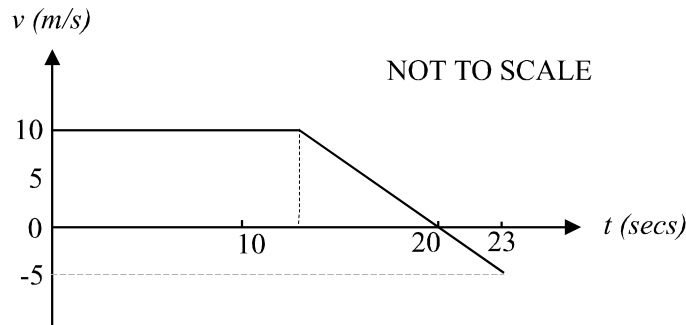
**Question 21**

The diagram above shows the velocity-time graph of a particle moving in a straight line. If, at  $t = 23$ , the displacement of the particle was  $162.5 \text{ m}$ , and the velocity was  $-5 \text{ m/s}$ , then the latest time when the particle had a velocity of  $10 \text{ m/s}$  would have been

- A.  $t = 11$   
 B.  $t = 12.5$   
 C.  $t = 13$   
 D.  $t = 13.5$   
 E.  $t = 14$

**Question 22**

If  $\vec{AB} = 2\vec{i} + 3\vec{j} + \vec{k}$  and  $\vec{AC} = \vec{i} - \vec{j} + 2\vec{k}$  then  $|\vec{BC}|$  is equal to

- A.  $3\sqrt{2}$   
 B.  $\sqrt{22}$   
 C.  $2\sqrt{5}$   
 D.  $5\sqrt{2}$   
 E.  $2\sqrt{21}$

**Question 23**

If  $\underline{u} = 2\underline{i} - \underline{j}$  and  $\underline{v} = \underline{i} - \underline{j} - 3\underline{k}$  then  $\hat{\underline{u}} \cdot \hat{\underline{v}}$  is equal to

- A.  $\frac{1}{55}(2\underline{i} - \underline{j})$   
 B.  $\frac{1}{\sqrt{55}}(2\underline{i} - \underline{j} - 3\underline{k})$   
 C.  $\frac{1}{\sqrt{55}}$   
 D.  $\frac{3}{\sqrt{55}}$   
 E. 1

**Question 24**

If  $\underline{u}$ ,  $\underline{v}$  and  $\underline{w}$  are non-zero vectors where  $\underline{u} = 2\underline{v}$  and  $\underline{w} = \frac{1}{3}\underline{u}$  then which one of the following is false?

- A.  $\underline{u}$  and  $\underline{v}$  are linearly dependent  
 B.  $\underline{u}$ ,  $\underline{v}$  and  $\underline{w}$  are linearly dependent  
 C.  $\underline{v}$  is one and a half times the length of  $\underline{w}$   
 D.  $\underline{v}$  is parallel to  $\underline{w}$   
 E.  $\underline{v}$  and  $\underline{w}$  are linearly independent.

**Question 25**

A group of bushwalkers leave base camp at point  $O$  and walk on a bearing of  $S60^\circ E$  for a distance of 2km to a point  $P$ . If  $\underline{i}$  and  $\underline{j}$  are unit vectors in the direction east and north

respectively then the position vector  $\vec{OP}$  is given by

- A.  $\underline{i} - \sqrt{3}\underline{j}$   
 B.  $\underline{i} + 2\sqrt{3}\underline{j}$   
 C.  $-\sqrt{2}\underline{i} + \sqrt{3}\underline{j}$   
 D.  $\sqrt{3}\underline{i} - \underline{j}$   
 E.  $\sqrt{3}\underline{i} + \underline{j}$

**Question 26**

A particle moves so that its displacement in metres from a fixed origin  $O$  at time  $t$  secs is given by

$$\underline{r} = 5t \underline{i} + \sin(2t) \underline{j} + t \underline{k}, \quad t \geq 0$$

The maximum speed reached by the particle in m/sec is

- A.  $\sqrt{7}$
- B.  $3\sqrt{3}$
- C.  $\sqrt{30}$
- D. 7
- E. 30

**Question 27**

A body of mass 2kg is moving with a velocity  $\underline{v}$  where  $\underline{v} = 3 \underline{i} + 2 \underline{j} + \underline{k}$ .

The momentum of the body, in kg m/s is given by

- A.  $2\sqrt{6}$
- B.  $2\sqrt{14}$
- C. 12
- D.  $\frac{3}{2} \underline{i} + \underline{j} + \frac{1}{2} \underline{k}$
- E.  $6 \underline{i} + 4 \underline{j} + 2 \underline{k}$

**Question 28**

A particle of 2kg is acted on by a force with magnitude  $(3 + t^2)$  newton. The velocity of the particle initially is 4 m/s in the direction of the force.

The speed of the particle, in m/s, 3 seconds later is

- A. 6
- B.  $\frac{19}{2}$
- C. 11
- D. 13
- E. 17

**Question 29**

A trunk of mass 20kg slides over a smooth surface which is inclined at an angle of  $45^\circ$  to the horizontal. The trunk accelerates down the slope at  $a \text{ m/s}^2$ .

The value of  $a$  is

- A.  $\frac{g}{2}$
- B.  $\frac{g}{\sqrt{2}}$
- C.  $\frac{\sqrt{3}g}{2}$
- D.  $\sqrt{2}g$
- E.  $20g$

**Question 30**

An object of mass 20kg is on a rough table top and is acted on by a force of  $P$  newton at an angle of  $30^\circ$  to the horizontal. The mass is attached to a light inextensible string, which passes over a smooth pulley and down the side of the table and is attached to a 10kg mass as indicated in the diagram.

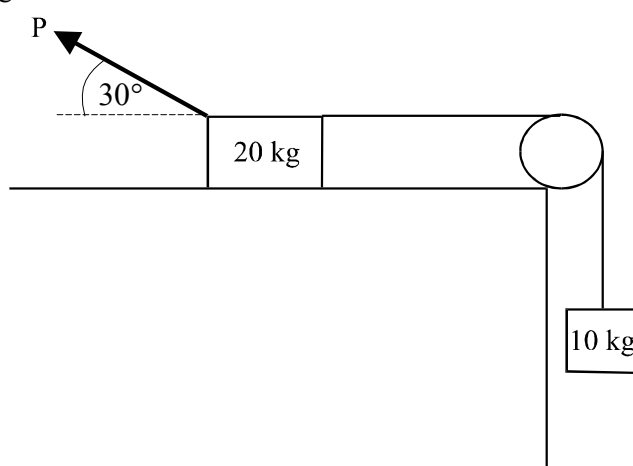

The normal force acting on the 20kg mass is  $N$  newton and the frictional force is  $Fr$  newton.

In the diagram, the 20kg mass accelerates towards the left at  $a \text{ m/s}^2$ .

For this system, which one of the following equations is true?

- A.  $a = \frac{\sqrt{3}P}{40} - \frac{g}{2}$
- B.  $a = \frac{\sqrt{3}P}{40} - \frac{Fr}{20}$
- C.  $a = \frac{P}{40} + Fr + \frac{g}{2}$
- D.  $a = \frac{\sqrt{3}P}{40} - \frac{Fr}{20} - \frac{g}{2}$
- E.  $a = \frac{\sqrt{3}P}{60} - \frac{Fr}{30} - \frac{g}{3}$



**PART II****Question 1**

Factorise over C

**i.**      $z^3 - 2z^2 + 5z - 10$

---

---

---

---

1 mark

**ii.**      $z^6 - 64$

---

---

---

---

---

2 marks

**Question 2**

A particle moves so that its acceleration vector at time  $t$  is given by  $\ddot{\mathbf{r}}(t) = 2\mathbf{i}$ ,  $t \geq 0$ .

When  $t = 0$ , its position vector was  $\mathbf{r}(0) = -\mathbf{i} - \mathbf{j}$  and its velocity vector was  $\dot{\mathbf{r}}(0) = \mathbf{j}$ .

- a. Find the position vector of the particle at time  $t$ .

---



---



---



---



---



---



---



---

2 marks

- b. On the set of axes below, sketch the path of the particle.

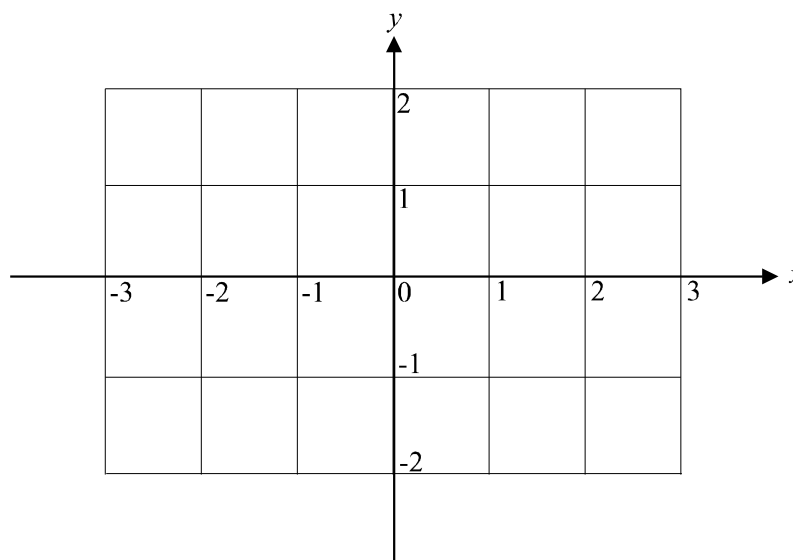

2 marks

**Question 3**

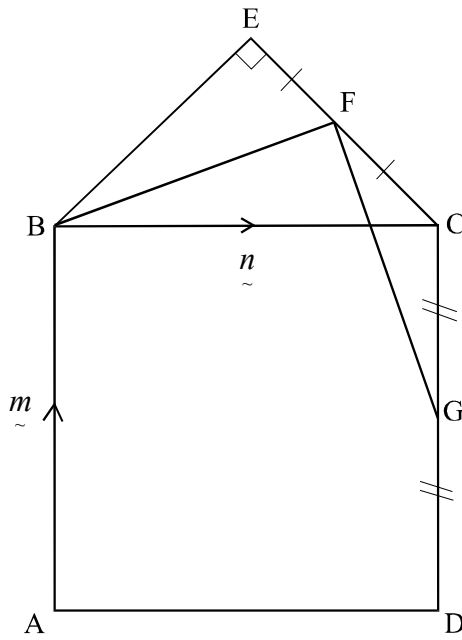

In the diagram above, ABCD is a square with  $\vec{AB} = \vec{m}$  and  $\vec{BC} = \vec{n}$ . BCE is a right-angled isosceles triangle. The point F is the midpoint of CE and the point G is the midpoint of CD. Use a vector method to prove that  $\angle BFG$  is a right angle.

---

---

---

---

---

---

---

---

---

---

---

---

---

---

---

---

---

---

---

---

---

---

---

---

3 marks

**Question 4**

- a. On the diagram below, indicate those points on the complex plane described by

$$\left\{ z : \text{Arg}(z) = \frac{3\pi}{4} \right\}.$$

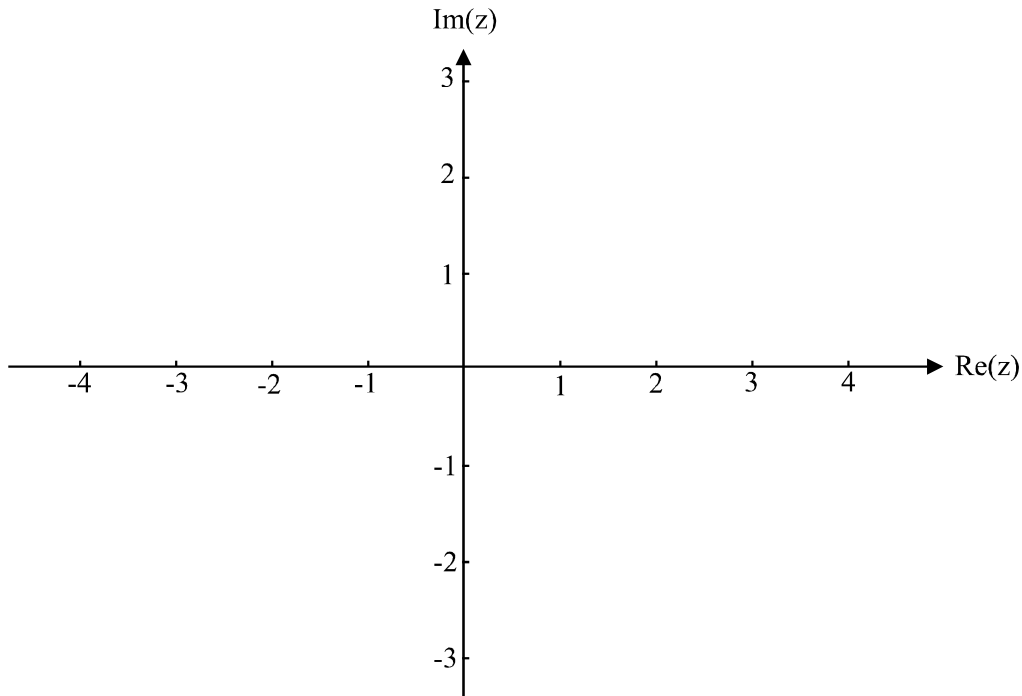

1 mark

- b. On the diagram below, indicate those points on the complex plane described by

$$\left\{ z : |z| \leq |z + 2 + 2i| \right\}$$

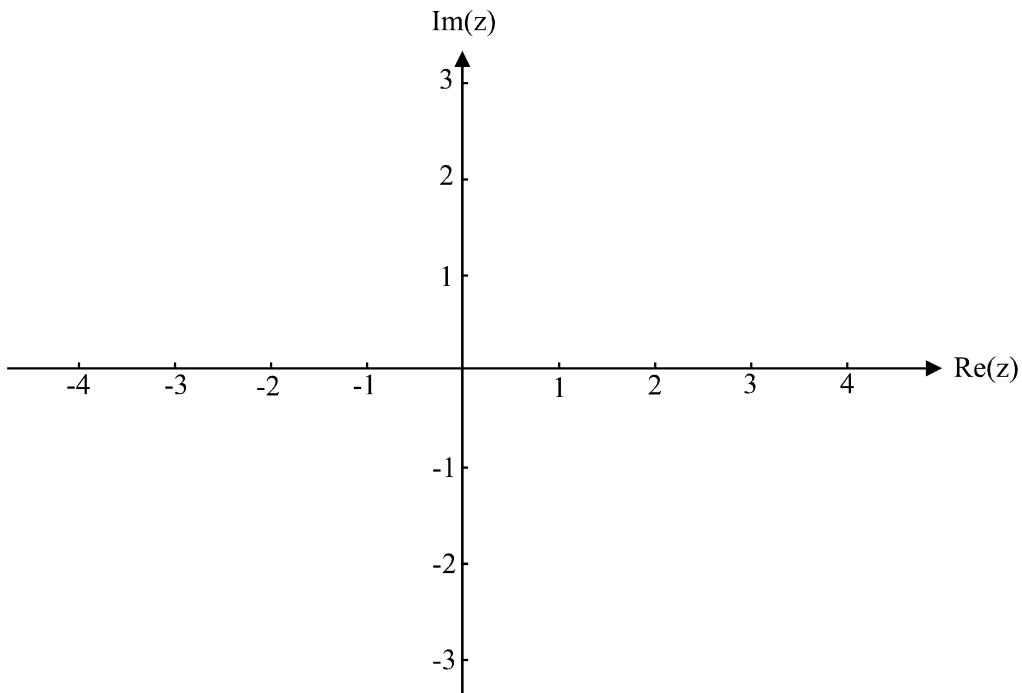

2 marks

**Question 5**

A bath bomb is dropped into a bath and immediately begins to dissolve. The mass, in grams, of the bath bomb at time  $t$ , in minutes, after the bomb is dropped, is given by  $m$ . The rate at which the bath bomb is dissolving is directly proportional to  $m$ .

- a. Write down a differential equation for  $m$  in terms of  $t$ .

---

---

---

1 mark

- b. The mass of the bath bomb is initially 100 grams and 10 minutes later it is 50 grams. Find an expression for  $m$  in terms of  $t$ .

---

---

---

---

---

---

---

---

---

---

2 marks



## Specialist Mathematics Formulas

### Mensuration

area of a trapezium:	$\frac{1}{2}(a + b)h$
curved surface area of a cylinder:	$2\pi rh$
volume of a cylinder:	$\pi r^2 h$
volume of a cone:	$\frac{1}{3}\pi r^2 h$
volume of a pyramid:	$\frac{1}{3}Ah$
volume of a sphere:	$\frac{4}{3}\pi r^3$
area of a triangle:	$\frac{1}{2}bc \sin A$
sine rule:	$\frac{a}{\sin A} = \frac{b}{\sin B} = \frac{c}{\sin C}$
cosine rule:	$c^2 = a^2 + b^2 - 2ab \cos C$

### Coordinate geometry

ellipse:	$\frac{(x-h)^2}{a^2} + \frac{(y-k)^2}{b^2} = 1$
hyperbola:	$\frac{(x-h)^2}{a^2} - \frac{(y-k)^2}{b^2} = 1$

### Circular (trigonometric) functions

$\cos^2(x) + \sin^2(x) = 1$	
$1 + \tan^2(x) = \sec^2(x)$	$\cot^2(x) + 1 = \operatorname{cosec}^2(x)$
$\sin(x + y) = \sin(x)\cos(y) + \cos(x)\sin(y)$	$\sin(x - y) = \sin(x)\cos(y) - \cos(x)\sin(y)$
$\cos(x + y) = \cos(x)\cos(y) - \sin(x)\sin(y)$	$\cos(x - y) = \cos(x)\cos(y) + \sin(x)\sin(y)$
$\tan(x + y) = \frac{\tan(x) + \tan(y)}{1 - \tan(x)\tan(y)}$	$\tan(x - y) = \frac{\tan(x) - \tan(y)}{1 + \tan(x)\tan(y)}$
$\cos(2x) = \cos^2(x) - \sin^2(x) = 2\cos^2(x) - 1 = 1 - 2\sin^2(x)$	
$\sin(2x) = 2\sin(x)\cos(x)$	$\tan(2x) = \frac{2\tan(x)}{1 - \tan^2(x)}$

function	Sin <sup>-1</sup>	Cos <sup>-1</sup>	Tan <sup>-1</sup>
domain	[-1, 1]	[-1, 1]	R
range	$\left[-\frac{\pi}{2}, \frac{\pi}{2}\right]$	[0, π]	$\left(-\frac{\pi}{2}, \frac{\pi}{2}\right)$

*Reproduced with permission of the Victorian Curriculum and Assessment Authority.*

*(These formula sheets have been copied from the 2001 Specialist Maths Exam 1. Teachers and students are reminded that changes to formula sheets are notified in the VCE Bulletins and on the VCAA website.)*

**Algebra (Complex numbers)**

$$z = x + yi = r(\cos \theta + i \sin \theta) = r \operatorname{cis} \theta$$

$$|z| = \sqrt{x^2 + y^2} = r$$

$$-\pi < \operatorname{Arg} z \leq \pi$$

$$z_1 z_2 = r_1 r_2 \operatorname{cis}(\theta_1 + \theta_2)$$

$$\frac{z_1}{z_2} = \frac{r_1}{r_2} \operatorname{cis}(\theta_1 - \theta_2)$$

$$z^n = r^n \operatorname{cis}(n\theta) \quad (\text{de Moivre's theorem})$$

**Calculus**

$$\frac{d}{dx}(x^n) = nx^{n-1}$$

$$\int x^n dx = \frac{1}{n+1} x^{n+1} + c, n \neq -1$$

$$\frac{d}{dx}(e^{ax}) = ae^{ax}$$

$$\int e^{ax} dx = \frac{1}{a} e^{ax} + c$$

$$\frac{d}{dx}(\log_e(x)) = \frac{1}{x}$$

$$\int \frac{1}{x} dx = \log_e(x) + c, \text{ for } x > 0$$

$$\frac{d}{dx}(\sin(ax)) = a \cos(ax)$$

$$\int \sin(ax) dx = -\frac{1}{a} \cos(ax) + c$$

$$\frac{d}{dx}(\cos(ax)) = -a \sin(ax)$$

$$\int \cos(ax) dx = \frac{1}{a} \sin(ax) + c$$

$$\frac{d}{dx}(\tan(ax)) = a \sec^2(ax)$$

$$\int \sec^2(ax) dx = \frac{1}{a} \tan(ax) + c$$

$$\frac{d}{dx}(\operatorname{Sin}^{-1}(x)) = \frac{1}{\sqrt{1-x^2}}$$

$$\int \frac{1}{\sqrt{a^2-x^2}} dx = \operatorname{Sin}^{-1}\left(\frac{x}{a}\right) + c, a > 0$$

$$\frac{d}{dx}(\operatorname{Cos}^{-1}(x)) = \frac{-1}{\sqrt{1-x^2}}$$

$$\int \frac{-1}{\sqrt{a^2-x^2}} dx = \operatorname{Cos}^{-1}\left(\frac{x}{a}\right) + c, a > 0$$

$$\frac{d}{dx}(\operatorname{Tan}^{-1}(x)) = \frac{1}{1+x^2}$$

$$\int \frac{a}{a^2+x^2} dx = \operatorname{Tan}^{-1}\left(\frac{x}{a}\right) + c$$

product rule: 
$$\frac{d}{dx}(uv) = u \frac{dv}{dx} + v \frac{du}{dx}$$

quotient rule: 
$$\frac{d}{dx}\left(\frac{u}{v}\right) = \frac{v \frac{du}{dx} - u \frac{dv}{dx}}{v^2}$$

chain rule: 
$$\frac{dy}{dx} = \frac{dy}{du} \frac{du}{dx}$$

*Reproduced with permission of the Victorian Curriculum and Assessment Authority.*

*(These formula sheets have been copied from the 2001 Specialist Maths Exam 1. Teachers and students are reminded that changes to formula sheets are notified in the VCE Bulletins and on the VCAA website.)*



mid-point rule:  $\int_a^b f(x)dx \approx (b-a)f\left(\frac{a+b}{2}\right)$

trapezoidal rule:  $\int_a^b f(x)dx \approx \frac{1}{2}(b-a)(f(a) + f(b))$

Euler's method: If  $\frac{dy}{dx} = f(x)$ ,  $x_0 = a$  and  $y_0 = b$ ,  
then  $x_{n+1} = x_n + h$  and  $y_{n+1} = y_n + hf(x_n)$

acceleration:  $a = \frac{d^2x}{dt^2} = \frac{dv}{dt} = v \frac{dv}{dx} = \frac{d}{dx}\left(\frac{1}{2}v^2\right)$

constant (uniform) acceleration:  $v = u + at$   $s = ut + \frac{1}{2}at^2$   
 $s = \frac{1}{2}(u + v)t$   
 $v^2 = u^2 + 2as$

### Vectors in two and three dimensions

$$\vec{r} = x\vec{i} + y\vec{j} + z\vec{k}$$

$$|\vec{r}| = \sqrt{x^2 + y^2 + z^2} = r$$

$$\vec{r}_1 \cdot \vec{r}_2 = r_1 r_2 \cos \theta = x_1 x_2 + y_1 y_2 + z_1 z_2$$

$$\dot{\vec{r}} = \frac{d\vec{r}}{dt} = \frac{dx}{dt}\vec{i} + \frac{dy}{dt}\vec{j} + \frac{dz}{dt}\vec{k}$$

### Mechanics

momentum:  $\vec{p} = m\vec{v}$

equation of motion:  $\vec{R} = m\vec{a}$

friction:  $F \leq \mu N$

*Reproduced with permission of the Victorian Curriculum and Assessment Authority.*

*(These formula sheets have been copied from the 2001 Specialist Maths Exam 1. Teachers and students are reminded that changes to formula sheets are notified in the VCE Bulletins and on the VCAA website.)*

# SPECIALIST MATHEMATICS

## TRIAL EXAMINATION 1

### MULTIPLE- CHOICE ANSWER SHEET

STUDENT NAME:.....

### INSTRUCTIONS

Fill in the letter that corresponds to your choice. Example:  A  B  C  D  E

The answer selected is B. Only one answer should be selected.

- |  |  |  |
|--|--|--|
| 1. <input type="checkbox"/> A <input type="checkbox"/> B <input type="checkbox"/> C <input type="checkbox"/> D <input type="checkbox"/> E  | 11. <input type="checkbox"/> A <input type="checkbox"/> B <input type="checkbox"/> C <input type="checkbox"/> D <input type="checkbox"/> E | 21. <input type="checkbox"/> A <input type="checkbox"/> B <input type="checkbox"/> C <input type="checkbox"/> D <input type="checkbox"/> E |
| 2. <input type="checkbox"/> A <input type="checkbox"/> B <input type="checkbox"/> C <input type="checkbox"/> D <input type="checkbox"/> E  | 12. <input type="checkbox"/> A <input type="checkbox"/> B <input type="checkbox"/> C <input type="checkbox"/> D <input type="checkbox"/> E | 22. <input type="checkbox"/> A <input type="checkbox"/> B <input type="checkbox"/> C <input type="checkbox"/> D <input type="checkbox"/> E |
| 3. <input type="checkbox"/> A <input type="checkbox"/> B <input type="checkbox"/> C <input type="checkbox"/> D <input type="checkbox"/> E  | 13. <input type="checkbox"/> A <input type="checkbox"/> B <input type="checkbox"/> C <input type="checkbox"/> D <input type="checkbox"/> E | 23. <input type="checkbox"/> A <input type="checkbox"/> B <input type="checkbox"/> C <input type="checkbox"/> D <input type="checkbox"/> E |
| 4. <input type="checkbox"/> A <input type="checkbox"/> B <input type="checkbox"/> C <input type="checkbox"/> D <input type="checkbox"/> E  | 14. <input type="checkbox"/> A <input type="checkbox"/> B <input type="checkbox"/> C <input type="checkbox"/> D <input type="checkbox"/> E | 24. <input type="checkbox"/> A <input type="checkbox"/> B <input type="checkbox"/> C <input type="checkbox"/> D <input type="checkbox"/> E |
| 5. <input type="checkbox"/> A <input type="checkbox"/> B <input type="checkbox"/> C <input type="checkbox"/> D <input type="checkbox"/> E  | 15. <input type="checkbox"/> A <input type="checkbox"/> B <input type="checkbox"/> C <input type="checkbox"/> D <input type="checkbox"/> E | 25. <input type="checkbox"/> A <input type="checkbox"/> B <input type="checkbox"/> C <input type="checkbox"/> D <input type="checkbox"/> E |
| 6. <input type="checkbox"/> A <input type="checkbox"/> B <input type="checkbox"/> C <input type="checkbox"/> D <input type="checkbox"/> E  | 16. <input type="checkbox"/> A <input type="checkbox"/> B <input type="checkbox"/> C <input type="checkbox"/> D <input type="checkbox"/> E | 26. <input type="checkbox"/> A <input type="checkbox"/> B <input type="checkbox"/> C <input type="checkbox"/> D <input type="checkbox"/> E |
| 7. <input type="checkbox"/> A <input type="checkbox"/> B <input type="checkbox"/> C <input type="checkbox"/> D <input type="checkbox"/> E  | 17. <input type="checkbox"/> A <input type="checkbox"/> B <input type="checkbox"/> C <input type="checkbox"/> D <input type="checkbox"/> E | 27. <input type="checkbox"/> A <input type="checkbox"/> B <input type="checkbox"/> C <input type="checkbox"/> D <input type="checkbox"/> E |
| 8. <input type="checkbox"/> A <input type="checkbox"/> B <input type="checkbox"/> C <input type="checkbox"/> D <input type="checkbox"/> E  | 18. <input type="checkbox"/> A <input type="checkbox"/> B <input type="checkbox"/> C <input type="checkbox"/> D <input type="checkbox"/> E | 28. <input type="checkbox"/> A <input type="checkbox"/> B <input type="checkbox"/> C <input type="checkbox"/> D <input type="checkbox"/> E |
| 9. <input type="checkbox"/> A <input type="checkbox"/> B <input type="checkbox"/> C <input type="checkbox"/> D <input type="checkbox"/> E  | 19. <input type="checkbox"/> A <input type="checkbox"/> B <input type="checkbox"/> C <input type="checkbox"/> D <input type="checkbox"/> E | 29. <input type="checkbox"/> A <input type="checkbox"/> B <input type="checkbox"/> C <input type="checkbox"/> D <input type="checkbox"/> E |
| 10. <input type="checkbox"/> A <input type="checkbox"/> B <input type="checkbox"/> C <input type="checkbox"/> D <input type="checkbox"/> E | 20. <input type="checkbox"/> A <input type="checkbox"/> B <input type="checkbox"/> C <input type="checkbox"/> D <input type="checkbox"/> E | 30. <input type="checkbox"/> A <input type="checkbox"/> B <input type="checkbox"/> C <input type="checkbox"/> D <input type="checkbox"/> E |