



# Victorian Certificate of Education 2006

SUPERVISOR TO ATTACH PROCESSING LABEL HERE

## STUDENT NUMBER

Letter

Figures

Words

# INFORMATION SYSTEMS

## Written examination

**Thursday 9 November 2006**

**Reading time: 11.45 am to 12.00 noon (15 minutes)**

**Writing time: 12.00 noon to 2.00 pm (2 hours)**

## QUESTION AND ANSWER BOOK

### Structure of book

<i>Section</i>	<i>Number of questions</i>	<i>Number of questions to be answered</i>	<i>Number of marks</i>
A	10	10	25
B	17	17	75
			Total 100

- Students are permitted to bring into the examination room: pens, pencils, highlighters, erasers, sharpeners, rulers and one scientific calculator.
- Students are NOT permitted to bring into the examination room: blank sheets of paper and/or white out liquid/tape.

### Materials supplied

- Question and answer book of 23 pages with a detachable insert containing a case study for Section B in the centrefold.

### Instructions

- Remove the insert containing the case study during reading time.
- Write your **student number** in the space provided above on this page.
- All written responses must be in English.

**Students are NOT permitted to bring mobile phones and/or any other unauthorised electronic devices into the examination room.**

**SECTION A – Short answer questions**

**Instructions for Section A**  
 Answer **all** questions in the spaces provided.

**Question 1**

A cinema uses a network of computers for selling tickets from day to day. What type of information system is the cinema using?

1 mark

**Question 2**

The diagram below shows the layout for a computer network used in a hairdressing salon.

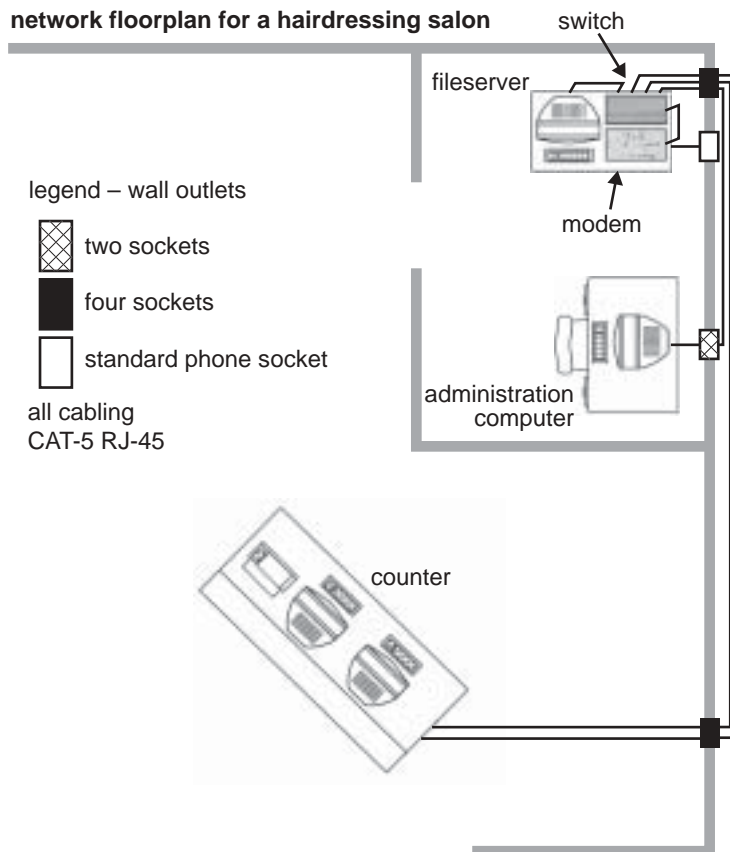

a. State the **topology** of the network above.

1 mark

b. State the **type** of network used above.

1 mark

**Question 3**

Describe the major difference between the functions of a switch and a modem in a network.

---



---



---



---



---

1 mark

**Question 4**

A network operating system provides services to network administrators and users. State two **important** services you would expect to be provided: one for the administrator and one for the user.

Administrator	User
<hr/>	<hr/>
<hr/>	<hr/>
<hr/>	<hr/>
<hr/>	<hr/>

2 marks

**Question 5**

Link each of these scenarios with one of the following stages of the systems development life cycle.

analysis, design, development, implementation, evaluation

A network administrator identifies the error rate of his organisation's Internet connection.	
A school replaces old computers in the computer room with new ones during the school holidays.	
A graphics company identifies some concerns in the way it <b>currently</b> stores and accesses past customers' details.	

3 marks

**Question 6**

A company, No Blots, supplies ink cartridges for printers which are sold only through the Internet. When customers place an order, the order is checked, a confirmation is sent back to the customer and the details of the order are sent to the warehouse. The diagram below shows the data flow diagram (DFD) for the No Blots online purchasing system. The diagram does not show the data sources and destinations.

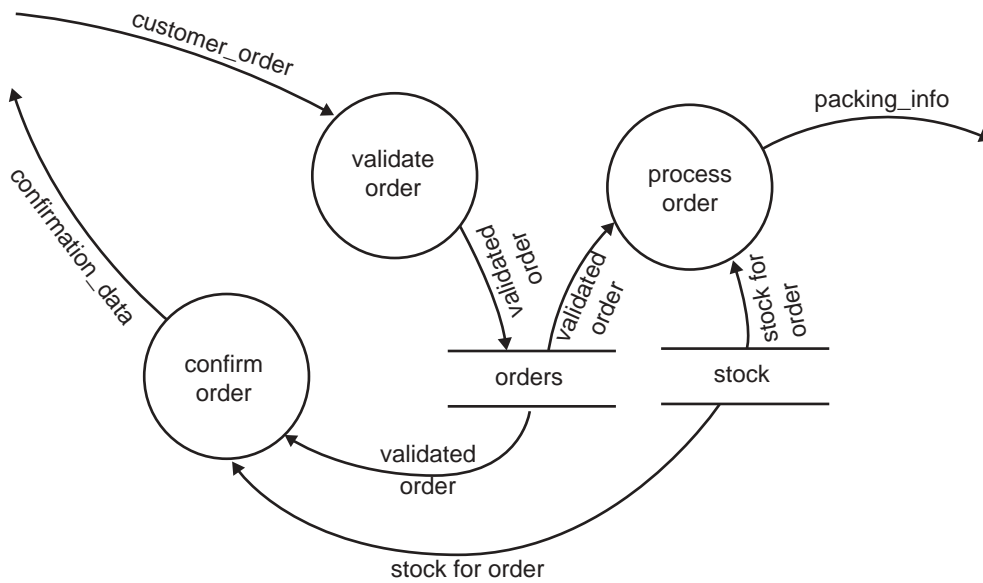

a. In a DFD a circle represents a process. Briefly explain what is meant by a process.

---



---

1 mark

b. In the DFD, what do the symbols labelled **stock** and **orders** represent?

---



---

1 mark

c. Complete the context diagram below for the No Blots system.

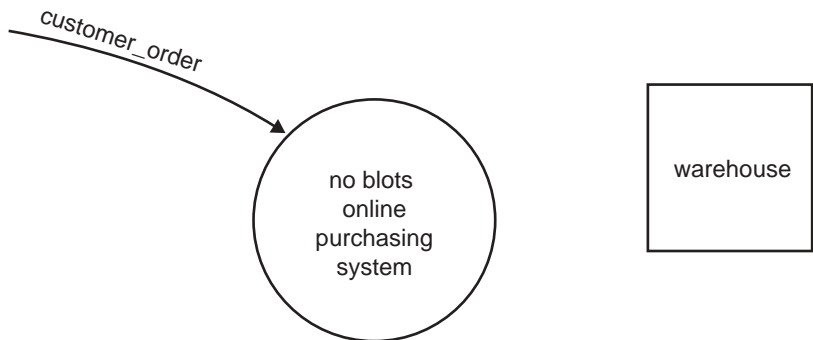

3 marks

**Question 7**

A computerised machine sorts fruit by weight. It uses a program that directs the fruit through three different gates according to weight. Below is a small segment of that program.

```

message ← "Fruit is undersized"
fruit_count ← 0
Repeat
    good_fruit ← true
    Close all gates
    Input (fruit_weight)
    If (fruit_weight > 30.00) then
        Open (gate1)
        fruit_count ← fruit_count + 1
    Else
        If (fruit_weight > 20.00) then
            Open (gate2)
            fruit_count ← fruit_count + 1
        Else
            good_fruit ← false
            Open (gate3)
        Endif
    Endif
    If not (good_fruit) then
        Output (message)
    Endif
Until eof                ***end of fruit
Output (fruit_count)

```

- a. Identify each variable shown in the table below as one of the following variable types: text, date, boolean, integer, floating point.

Variable	Type
fruit_count	
message	
good_fruit	

3 marks

- b. The code is to be written as a procedure within a larger program. The programmer decides to name the procedure 'helen' in honour of his girlfriend. Briefly explain why this is a poor choice of name for the procedure.

---



---



---



---

1 mark

**Question 8**

Explain the difference between Read Only Memory (ROM) and Random Access Memory (RAM).

---



---



---



---



---

2 marks

**Question 9**

Describe how a router can help make a large network run more efficiently.

---



---



---



---

2 marks

**Question 10**

A company requires a particular task to be carried out using a computer. It has a choice of two programs, A and B. The company would like to evaluate both programs so that it can decide which to purchase.

Several criteria can be used to evaluate software, including

effectiveness, efficiency, maintainability, reliability, usability.

The company will perform three trials, each trial measuring a different criterion. The trials are shown in the table below. For each trial, state which of the criteria listed above is being measured.

Trial	Criterion being measured
Carefully examine the user interface of each program.	
Give the same task to both programs and record the time each takes to complete it.	
Have each program run the same task 1000 times and count how many times each crashes.	

3 marks

Total 25 marks

**END OF SECTION A**

**SECTION B – Case study****Instructions for Section B**

Answer **all** questions in the spaces provided.

Remove the case study insert and read **all** the information provided before you answer these questions.

Answers must apply to the case study.

Lucy has decided she needs some help to introduce her new computer climate control system for her greenhouses. She employs a system analyst, Susan, and outlines her current system and what she would like to achieve with the new system.

**Question 1**

Susan asks Lucy for technical information about the sensors used in her current system, but Lucy cannot help her.

- a. Identify a primary source from which Susan can obtain more information about the sensors.

---

1 mark

- b. State **two** examples of the technical information Susan can expect to obtain from the primary source.

---



---



---



---



---



---



---

2 marks

**Question 2**

Lucy describes the temperature control to Susan.

The temperature in a greenhouse room is constantly monitored and if it falls below 19°C a heater is turned on. If the temperature rises above 21°C the heater is turned off. When the temperature goes over 25°C vents are opened to allow fresh air into the room and if it gets hotter than 29°C evaporative cooling is turned on. Once the temperature drops below 24°C vents are closed and cooling stops.

Susan finds this description confusing so she documents this process with a Nassi-Shneiderman (NS) diagram.

Susan’s NS diagram is shown below.

**Five** items are missing from it.

From the following list choose **only five items** and write each item in the correct place in the diagram.

1. turn water on
2. turn heater off
3. turn evaporative cooling on
4. temperature > 30°C
5. temperature > 29°C
6. temperature < 24°C
7. temperature < 19°C
8. monitor temperature

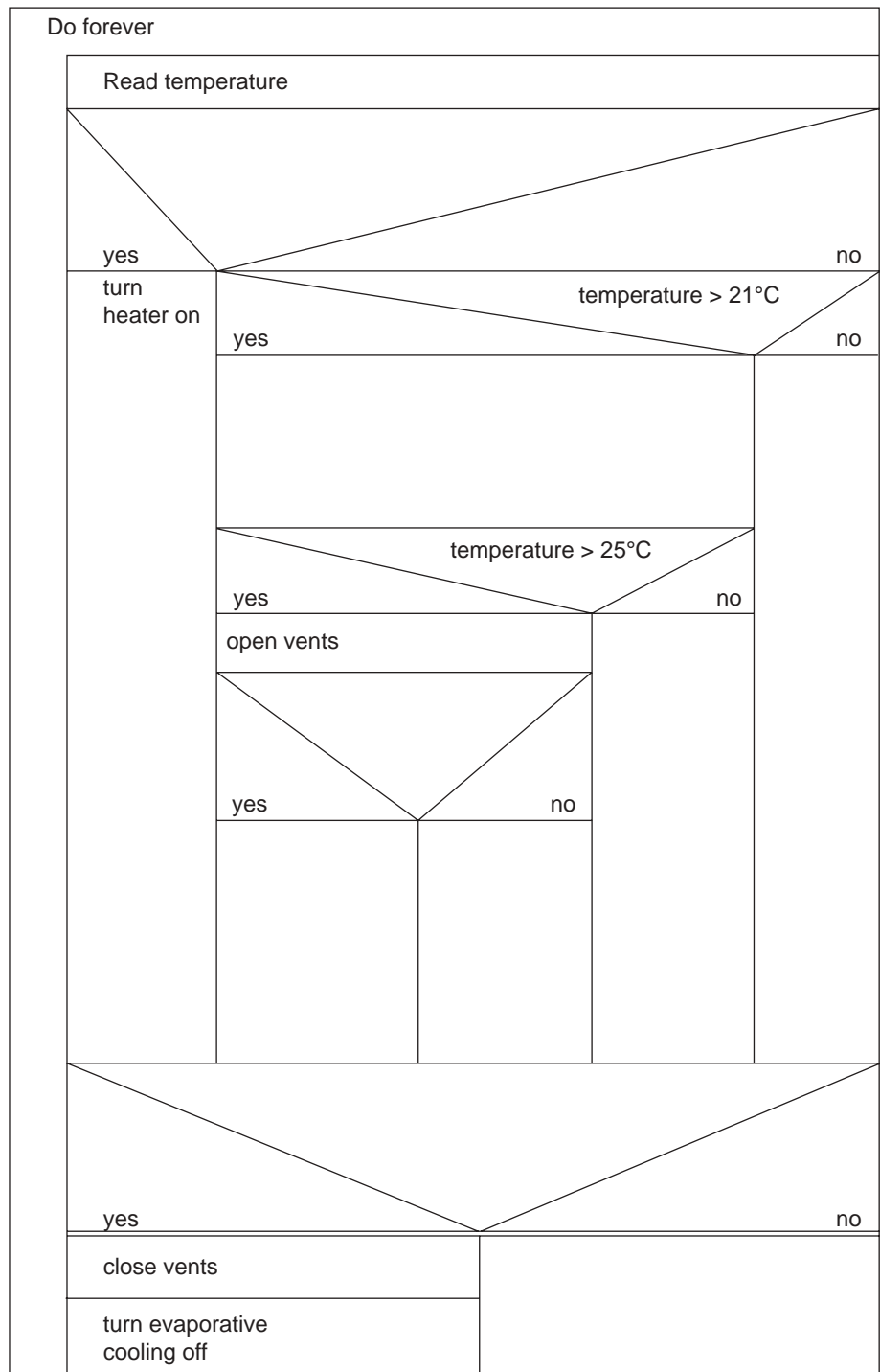

5 marks





**Question 4**

Susan has discovered a shareware program on the Internet that appears to suit Lucy’s needs. The program uses a number of standard interface screens that will allow Lucy to make adjustments to the conditions in the greenhouses. Other screens are used to alert Lucy to problems in the greenhouses.

The following screen is a typical data entry screen.



Lucy thinks that this screen has a major design fault.

- a. Identify this fault.

---

---

---

---

1 mark

- b. Suggest how the fault can be corrected.

---

---

---

---

---

---

1 mark

The following screen is used to alert Lucy to problems with the growing conditions in the greenhouses.



Lucy thinks that this screen also has a major design fault.

c. Identify this fault.

---

---

1 mark

d. Suggest how the fault can be corrected.

---

---

---

---

---

1 mark



After checking carefully Lucy is satisfied that she can allow Peter to fix problems and make any changes that he would like.

### Question 6

Lucy wants to receive an alert message if the humidity drops below 20% or rises above 80%. Peter writes a program module to do this and tests it with the following test data.

Test data	Expected results
19	Alert
25	No Alert
80	No Alert

- a. Susan is not satisfied that this data has fully tested the program module. Explain why.

---



---



---



---



---



---



---

2 marks

- b. Explain exactly what Peter needs to do to satisfy Susan's concerns.

---



---



---



---



---



---



---

2 marks

**Question 7**

One of the errors that Peter has found is in the code to control the shade curtain motor.

For her flowering orchids, Lucy wants the shade curtain to be closed if the light exceeds 15 000 lux (MaxLight). She also wants the shade curtain closed when the temperature exceeds 33°C (MaxTemp). The curtain should only be opened when the light falls below 7 000 lux (MinLight) and when the temperature drops below 30°C (MinTemp). The light and temperature values will vary depending on the plants grown in each greenhouse ‘room’.

Peter has found that the code follows the algorithm below.

**Begin**

**If** Temperature > MaxTemp **Or** Light >MaxLight **Then**  
     CurtainMotor (Close)

**Endif**

**If** Temperature < MinTemp **Or** Light < MinLight **Then**  
     CurtainMotor (Open)

**Endif**

**End**

- a. Below is a testing table. Work out the action that the algorithm finally produces and complete the **last** column.

		<b>Action required</b>	<b>Action produced by algorithm</b>
<b>temperature</b>	<b>light</b>	<b>curtain motor</b>	<b>curtain motor</b>
34	16 000	Close	
34	5 000	Close	
29	5 000	Open	
29	16 000	Close	

4 marks

- b. A line in the algorithm contains a logic error. Identify that line by writing it out in full.

---

1 mark

- c. Describe how this error can be corrected.

---



---



---

1 mark

**Question 8**

The new system requires a computer in each nursery to control the greenhouse climates. The orchids may be damaged if these computers fail to work. Each computer will be placed in a small enclosed area as shown in Figure 3 of the case study.

**a.** List **three** separate hazards to which these computers will be exposed.

1. \_\_\_\_\_

\_\_\_\_\_

2. \_\_\_\_\_

\_\_\_\_\_

3. \_\_\_\_\_

\_\_\_\_\_

3 marks

**b.** Select **one** hazard and describe why this is a concern for Lucy.

\_\_\_\_\_

\_\_\_\_\_

\_\_\_\_\_

\_\_\_\_\_

\_\_\_\_\_

\_\_\_\_\_

2 marks

**c.** Describe how Lucy should protect the computers from the hazard described in **part b**.

\_\_\_\_\_

\_\_\_\_\_

\_\_\_\_\_

\_\_\_\_\_

2 marks

**Question 9**

Lucy wishes to connect the computer in the local nursery with a computer in her house so she can monitor the greenhouse from her study. The distance is approximately 30 metres. She has two choices.

Option 1: to connect via CAT-5 cable

Option 2: to set up a wireless link

Select the better option for Lucy. Justify your selection by comparing the **two** options.

---

---

---

---

---

---

---

---

---

---

---

2 marks



**Question 10**

Lucy needs to monitor her new remote nursery as described in the case study insert. She needs to connect the nursery computer (five kilometres away) to her home computer. She expects the remote nursery computer to transmit approximately 2 KB of data every five minutes to the home computer. She has a phone service to the remote nursery. She is investigating a number of options for this task.

- a. What type of network does Lucy want to set up?

---

1 mark

- b. For each of the following three options outline **one** strength.

Option 1: Use dial up Internet – get the computer to use the Internet by dialling in every 5 minutes.

---



---

Option 2: Use broadband instead of dial up Internet.

---



---

Option 3: Set up a microwave link.

---



---

3 marks

- c. Select the best possible option for Lucy. Justify your selection by discussing the **three** options above.

---



---



---



---



---



---



---



---

3 marks



**Question 12**

Lucy has a huge project to convert her current greenhouse, and to include her new greenhouses into the new computer climate controlled system.

For each greenhouse, she has to coordinate tasks such as

- purchasing new equipment
- removing old equipment
- installing new equipment including computers, cabling and sensors
- installing the software
- setting up the network.

a. Which **project management tool** would be most suitable for Lucy to use to plan her project?

---

1 mark

b. Describe **three** ways in which this project management tool will help Lucy manage the project.

---

---

---

---

---

---

---

---

---

---

3 marks

**Question 13**

Lucy has decided to trial the new computerised greenhouse climate control system in her local nursery first before installing it in her remote nursery. She also considered two other methods.

- running both the new and current system at the same time for a month
- changing over to the new system in both nurseries all at once

a. Identify the type of changeover method Lucy has decided to use.

---

1 mark

b. Explain why this method is a better choice for Lucy than the other two options.

---

---

---

---

---

---

---

---

---

---

---

---

3 marks

**Question 14**

Lucy has read a great deal lately about viruses that can attack home computers through Internet connections. Lucy is relying on her Internet connection to monitor her remote nursery's greenhouse conditions and to alert her of any problems. It is important that her computer is always turned on and connected to the Internet.

Describe **two** ways Lucy could protect her computer against attack from viruses.

1. \_\_\_\_\_

\_\_\_\_\_

\_\_\_\_\_

\_\_\_\_\_

\_\_\_\_\_

2. \_\_\_\_\_

\_\_\_\_\_

\_\_\_\_\_

\_\_\_\_\_

\_\_\_\_\_

4 marks

**Question 15**

Lucy had to be rushed to hospital for an appendix operation. She was forced to leave her nurseries in the hands of a fellow orchid grower, Edmund. Edmund is very familiar with looking after orchids but has never used a system like Lucy's new greenhouse climate control system. Lucy had no time to give Edmund instructions on running the system so she told Edmund where to find the 365-page user manual.

- a. Describe another form of user documentation that should have been available for Lucy to give to Edmund.

\_\_\_\_\_

\_\_\_\_\_

1 mark

- b. Identify the main topics this documentation should contain.

\_\_\_\_\_

\_\_\_\_\_

\_\_\_\_\_

\_\_\_\_\_

\_\_\_\_\_

\_\_\_\_\_

3 marks

**SECTION B – continued  
TURN OVER**

**Question 16**

After Lucy’s system had been set up and working for about three months, a data security company contacted Lucy about backing up her data. This company uses the Internet to transfer customer data to their storage facilities. The company has made the following three claims about their service.

Claim 1: Lucy would not need to worry about the backup, they would do it all for her.

Claim 2: Lucy would always be able to access the backup.

Claim 3: They would keep Lucy’s backup on a very secure site that is well away from the nurseries.

Discuss what Lucy needs to investigate before accepting each claim.

Claim 1

---

---

---

---

Claim 2

---

---

---

---

Claim 3

---

---

---

---

2 + 2 + 2 = 6 marks

**Question 17**

When the system was being designed, Lucy produced a list of objectives for the new system.

Objective 1: The temperature, light and humidity do not go outside the set limits.

Objective 2: No more than two errors in a month will be recorded.

Objective 3: Record all errors and immediately send an alert message to her mobile phone.

After six months of operation, Lucy thinks that her new greenhouse climate control system is a success. However, she wants some data to support her feeling, so she has checked the error log from both nursery computers. The content of the error log is shown below.

12-3-2006	17:31:57	vents stuck	action required
15-3-2006	03:54:29	mist sprayers malfunction	action required
27-5-2006	13:45:11	greenhouse too hot	action required
31-8-2006	07:34:51	vents stuck	action required
03-9-2006	14:04:33	greenhouse too bright	action required

a. For **Objective 1**, indicate the data that informs Lucy that the objective **is not being** met.

---



---



---



---

1 mark

b. For **Objective 2**, indicate the data that informs Lucy that the objective **is being met**.

---



---



---



---

1 mark

c. What additional data needs to be checked to evaluate if **Objective 3** has been met? Explain.

---



---



---



---



---



---



---



---

2 marks

**CASE STUDY INSERT**

Please remove from the centre of this book during reading time.

Lucy is the owner of Lucky Orchids which specialises in growing orchids for the pot plant market. Her nursery, a 600 square metre heated greenhouse, is located next to her house in country Victoria. At most times during the year there are 100 000 plants growing in the nursery. The orchids are worth about \$2 000 000.

**Lucy's current system**

So she can grow the best orchids, Lucy has to have different growing conditions at different stages of a plant's life. For example, her seedlings and younger plants require less light, a higher temperature and higher humidity than older plants. To achieve this, Lucy has divided the greenhouse into three rooms.

Each room has its own set of climate control units as shown in Figure 1 on the following page. They can be set according to the needs of the plants in that room.

For example, for Lucy's flowering plants

- if the light exceeds 15 000 lux (a measure of light brightness), shade curtains are automatically pulled across the roof
- if the humidity rises above 80%, the mist sprayers are turned off
- if the temperature is above 25°C, vents are opened to allow fresh air into the greenhouse.

Each unit operates independently and automatically although sometimes one will fail. This can have serious consequences for Lucy's plants and she can only check each unit by going into the greenhouse and reading various climate gauges in the greenhouse. For example, if heaters fail at night she will not know until the morning when she physically checks the thermometer. Cool overnight temperatures will cause her plants to grow more slowly or even kill them. Failure to control light or humidity may also cause damage. Unfortunately, Lucy cannot be in the nursery every day because of personal and business commitments.



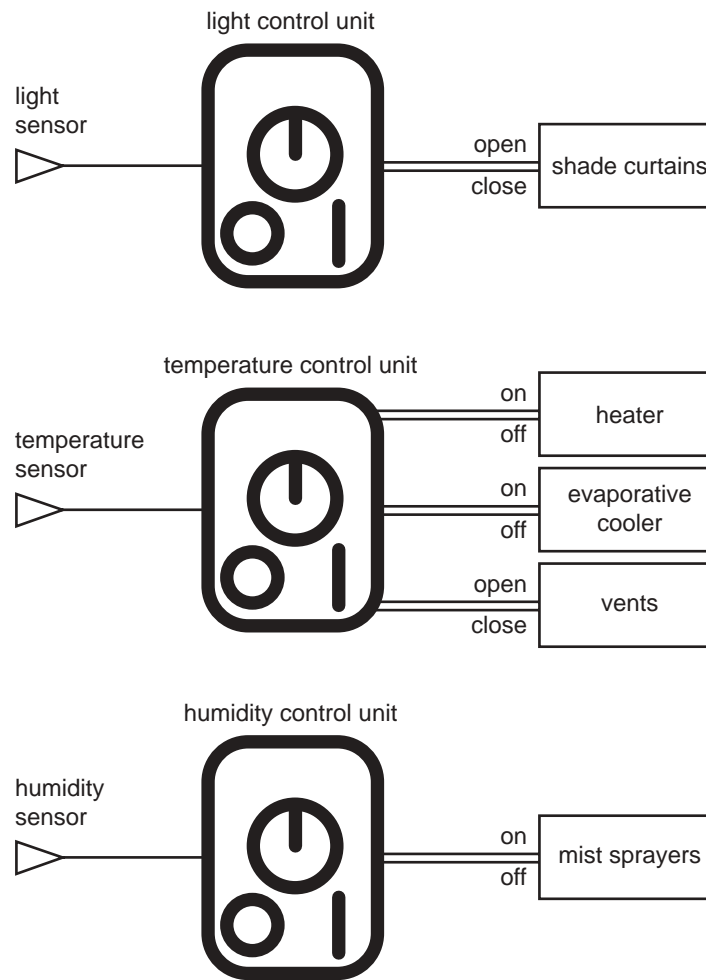

**Figure 1. Climate control units for one room**

With the current system, Lucy can grow plants from seedling to flowering in  $2\frac{1}{2}$  years. On a recent trip to Holland, to purchase new varieties of plants, she noted that Dutch nurseries were growing plants from seedling to flowering in  $1\frac{1}{2}$  to 2 years. The reason for this is that the climate in their greenhouses is computer controlled. All the sensors and climate control devices are connected to a computer. A computer program then maintains ideal growing conditions. For example, if the temperature gets too high, shade curtains are activated regardless of the light level, and in extreme conditions, mist sprayers are also turned on, even if humidity is above 80%.

### Lucy's new system

Lucy recently purchased a new nursery five kilometres from her house. It has unheated greenhouses covering 3000 square metres of land. Because her new greenhouses will have to be upgraded for her orchids, Lucy decides that she wants to introduce a computer controlled climate system into both her existing local nursery and her new remote nursery.

She would like this computer climate control system to

- combine control of all climate devices to produce better conditions for orchid growth
- allow her to remotely check and alter the conditions in each greenhouse room in both nurseries
- record errors and send an alert message to her mobile phone if something fails.

Lucy imagines that the new system will be something like that shown in Figures 2 and 3.

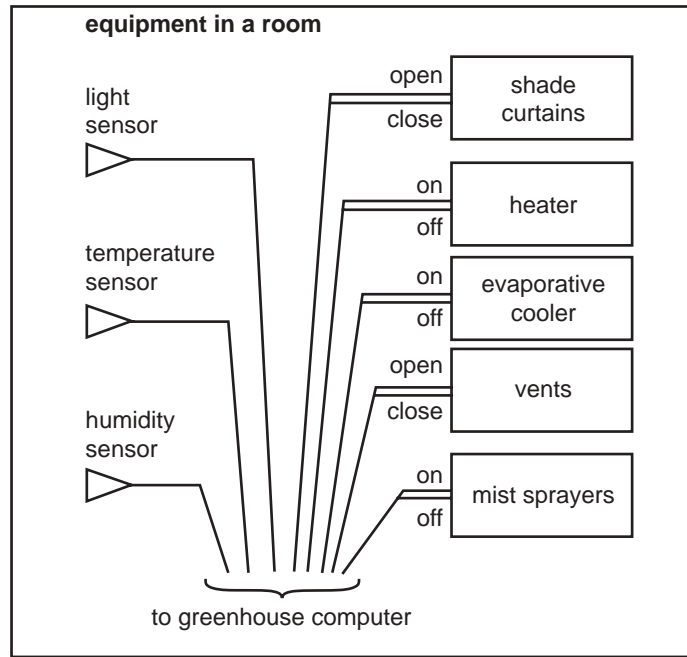

**Figure 2. Proposed equipment plan for a room**

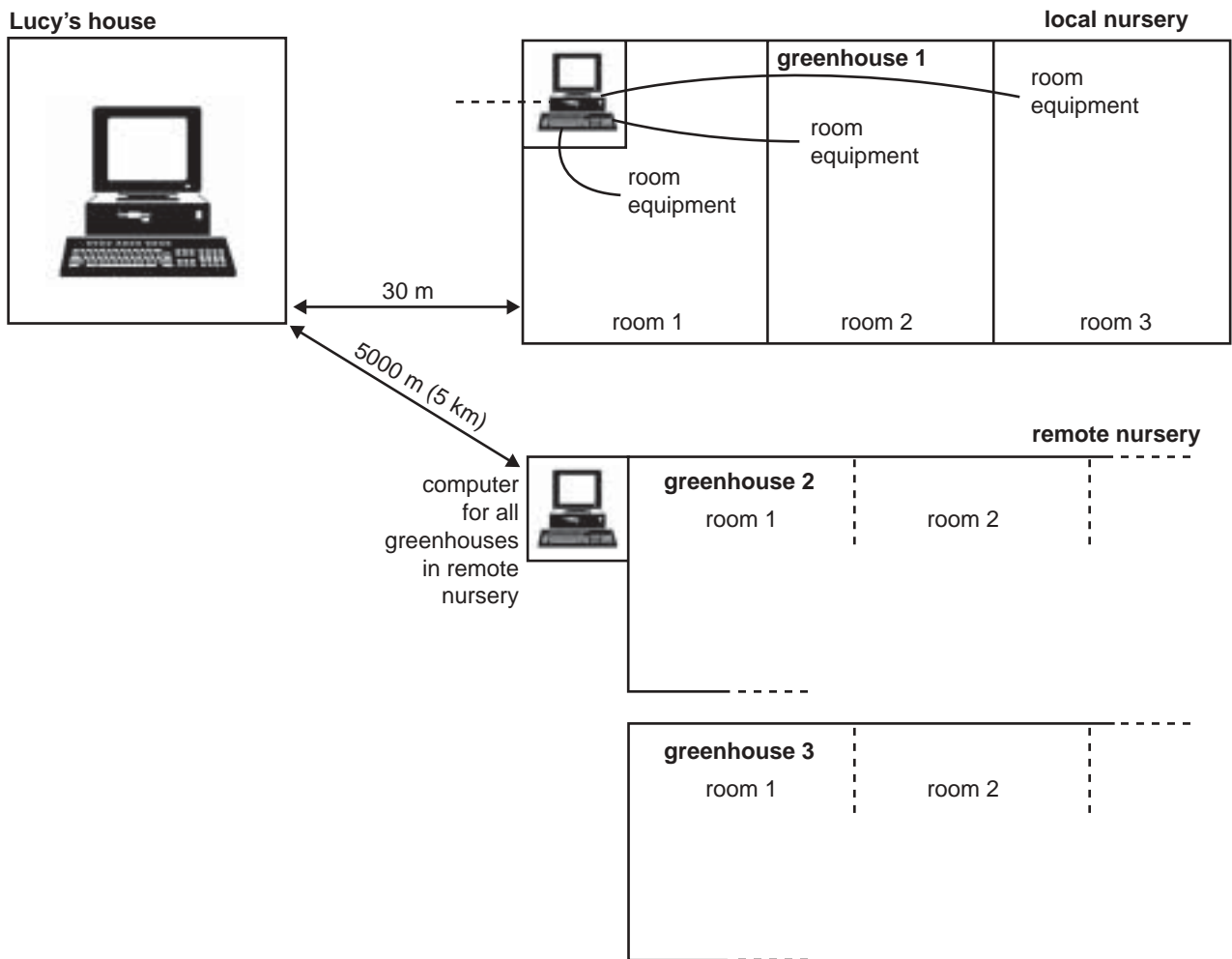

**Figure 3. Proposed plan for the two nurseries**

**END OF CASE STUDY INSERT**