

# 2022

# VCE

# Physics

# Trial Examination



**Kilbaha Education**

Quality educational content

**Kilbaha Education**  
PO Box 2227  
Kew Vic 3101  
Australia

**Tel: (03) 9018 5376**

[kilbaha@gmail.com](mailto:kilbaha@gmail.com)

<https://kilbaha.com.au>

*All publications from Kilbaha Education are digital and are supplied to the purchasing school in both WORD and PDF formats with a school site licence to reproduce for students in both print and electronic formats.*



# Kilbaha Education

Quality educational content

**Kilbaha Education (Est. 1978) (ABN 47 065 111 373)**  
**PO Box 2227**  
**Kew Vic 3101**  
**Australia**

**Tel: +613 9018 5376**  
**Fax: +613 9817 4334**  
**Email: [kilbaha@gmail.com](mailto:kilbaha@gmail.com)**  
**Web: <https://kilbaha.com.au>**

## **IMPORTANT COPYRIGHT NOTICE FOR KILBAHA PUBLICATIONS**

- (1) The material is copyright. Subject to statutory exception and to the provisions of the relevant collective licensing agreements, no reproduction of any part may take place without the written permission of Kilbaha Pty Ltd.
- (2) The contents of these works are copyrighted. Unauthorised copying of any part of these works is illegal and detrimental to the interests of the author(s).
- (3) For authorised copying within Australia please check that your institution has a licence from <https://www.copyright.com.au> This permits the copying of small parts of the material, in limited quantities, within the conditions set out in the licence.
- (4) All pages of Kilbaha files must be counted in Copyright Agency Limited (CAL) surveys.
- (5) Kilbaha files must **not** be uploaded to the Internet.
- (6) Kilbaha files may be placed on a password protected school Intranet.

**Kilbaha educational content has no official status and is not endorsed by any State or Federal Government Education Authority.**

While every care has been taken, no guarantee is given that the content is free from error. Please contact us if you believe you have found an error.

### **CAUTION NEEDED!**

All Web Links when created linked to appropriate Web Sites. Teachers and parents must always check links before using them with students to ensure that students are protected from unsuitable Web Content. Kilbaha Education is not responsible for links that have been changed in its publications or links that have been redirected.



# Kilbaha Education

Quality educational content

**STUDENT NUMBER****Letter**

<b>Figures</b>		
<b>Words</b>		

--

**Student Name** .....

**PHYSICS****Trial Written Examination**

Reading time: 15 minutes

Writing time: 2 hours 30 minutes

**QUESTION AND ANSWER BOOK****Structure of book**

<i>Section</i>	<i>Number of questions</i>	<i>Number of questions to be answered</i>	<i>Number of marks</i>
A	20	20	20
	<i>Number of questions</i>	<i>Number of questions to be answered</i>	<i>Number of marks</i>
B	20	20	110
			Total 130

**Materials allowed**

- Students are permitted to bring into the examination room: pens, pencils, highlighters, erasers, sharpeners, rulers, up to two pages (two A4 sheets) of pre-written notes (typed or handwritten) and one scientific calculator.
- Students are NOT permitted to bring into the examination room: blank sheets of paper and/or white out liquid/tape.

**Materials supplied**

- Question and Answer book of 51 pages. A formula sheet of 3 pages.
- Answer sheet for multiple-choice questions.
- All written responses must be in English.

**Instructions**

- Write your student **number** and **name** in the space provided above on the Answer Booklet and also on the Multiple Choice answer sheet at the front of the Question and Answer book.
- Unless otherwise indicated, the diagrams in this book are **not** drawn to scale.

**At the end of the examination**

- Place the answer sheet for multiple-choice questions inside the front cover of this answer book.

**Students are NOT permitted to bring mobile phones and/or any other unauthorised electronic devices into the examination room.**

©Kilbaha Pty Ltd 2022

# VCE PHYSICS 2022

## Trial Written Examination

### MULTIPLE-CHOICE ANSWER SHEET

**Student Name** \_\_\_\_\_

**Student Number** \_\_\_\_\_

Use a **PENCIL** for **ALL** entries. For each question, shade the box that indicates your answer.

All answers must be completed like **THIS** example. This example selects **B**.

A	<input checked="" type="checkbox"/>	C	D
---	-------------------------------------	---	---

Marks will **NOT** be deducted for incorrect answers.

**NO MARK** will be given if more than **ONE** answer is completed for any question.

If you make a mistake, **ERASE** the incorrect answer. **DO NOT** cross it out.

**ONLY ONE ANSWER PER QUESTION**

Question	A	B	C	D
1				
2				
3				
4				
5				
6				
7				
8				
9				
10				

Question	A	B	C	D
11				
12				
13				
14				
15				
16				
17				
18				
19				
20				

## SECTION A Multiple choice questions

Answer all questions for this section in pencil on the multiple choice answer provided.

Choose the response which is clearly correct or best answers the question.

A correct answer scores 1, an error scores 0.

Marks are not deducted for incorrect answers.

No marks are given if two or more selections are made to the answers.

Unless otherwise indicated the diagrams are not drawn to scale.

The value of  $g$  is to be taken as  $9.8 \text{ ms}^{-2}$  unless otherwise stated.

### Question 1

Two electromagnets are shown in **Figure 1** below.

The direction of current flow through the windings is shown.

At Point X the strength of the magnetic field produced by Electromagnet Y is 0.030 T. This point is equally spaced from the end of each electromagnet.

Electromagnet Z has a field of 0.045 T at point X, but the current producing it is the same as in Electromagnet Y.

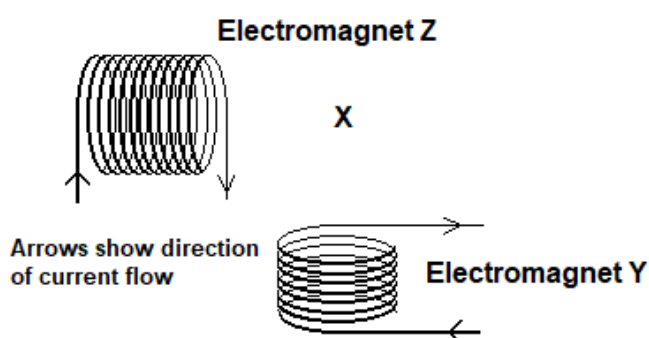

**Figure 1**

The Earth's magnetic field can be ignored at this stage, as its strength is very much less.

Which answer best gives the magnitude of the resultant field at Point X produced by the two electromagnets?

- A 0.015 T
- B 0.042 T
- C 0.054 T
- D 0.075 T

**Question 2**

The current in the electromagnets in **Question 1** is now reduced equally in both and the field produced by Electromagnet Y is now  $3.0 \times 10^{-5}$  T.

The Earth's field is also  $3.0 \times 10^{-5}$  T at this location and must also be considered now. It is directed towards magnetic north which is shown on the direction arrows.

Which arrow best shows the direction of the resultant field at Point X produced by the three fields?

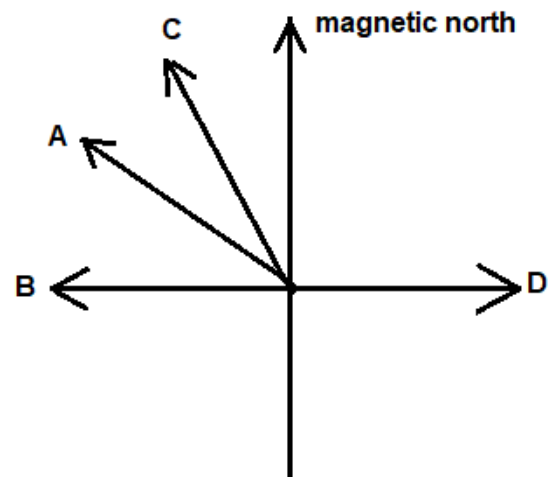

- A
- B
- C
- D

### Question 3

Electron microscope calibration spheres were placed into an electric field of  $4.0 \times 10^4 \text{ V m}^{-1}$ . Each sphere has a mass  $7.2 \times 10^{-15} \text{ kg}$ .

The motion of one sphere was measured and found to be stationary, held balanced between the electric and the gravitational fields. See

#### Figure 2.

#### Figure 2

A small plastic sphere is stationary between two electrically charged plates.

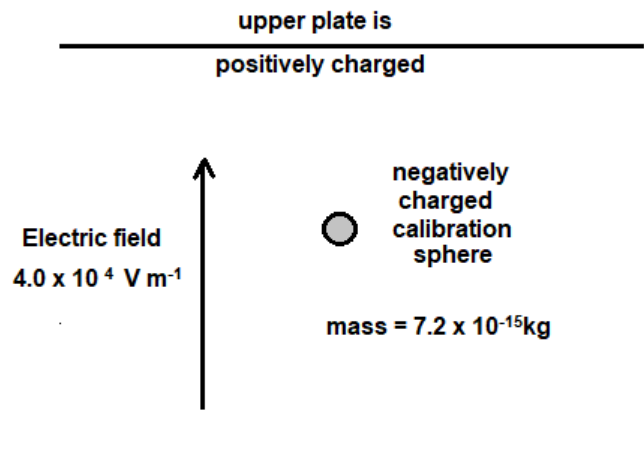

How many electron charges must be on the plastic sphere? Select the best answer.

- A 1
- B 11
- C 108
- D 110

**Question 4**

In a magnetic field system, what form of polar structure does the field have?

- A** In experiments with magnets, a north pole magnet will attract a south pole magnet. On the other hand, like magnetic pole magnets repel. The field is dipolar.
- B** Without poles, because the magnetic field penetrates through the bar of a magnet. The direction of the field can be identified at any point on the loop.
- C** Monopolar, because any magnetic pole will have field lines, both entering and leaving the pole. All magnets have both north and south poles.
- D** Dipolar, because any magnetic source will have field lines, both entering and leaving the magnet. Dividing a magnet does not produce separate north and south poles.



### Question 5

When a vehicle with a siren is nearby, pedestrians will hear the sound of the siren change from that when the vehicle is approaching the intersection, to that when departing.

This change in sound is the Doppler Effect. It is produced:

- A** When the vehicle is moving closer to the intersection, pedestrians sense the sound as having a higher frequency, because they receive the sound at higher speed, as described by  $v = f\lambda$ . This is reversed as the vehicle departs.
- B** When the vehicle is moving closer to the intersection, pedestrians sense the sound as having a lower frequency, because they receive the sound at lower speed, as described by  $v = f\lambda$ . This is reversed as the vehicle departs.
- C** The speed of sound is constant,  $v = f\lambda$ . As the vehicle is moving closer to the pedestrians, they sense the sound as having a lower frequency. They receive the next cycle of sound more slowly, giving it a shorter wavelength which lowers the frequency. This is reversed as the vehicle departs.
- D** The speed of sound is constant,  $v = f\lambda$ . As the vehicle is moving closer to the pedestrians, they sense the sound as having a higher frequency. They receive the next cycle of sound more quickly, giving it a shorter wavelength which raises the frequency. This is reversed as the vehicle departs.

### Question 6

An electron beam passes through a narrow slit and strikes a screen.

A series of high and low intensity regions (maxima and minima) appear on the screen.

See **Figure 3**.

**Figure 3** An electron beam passing through a narrow slit.

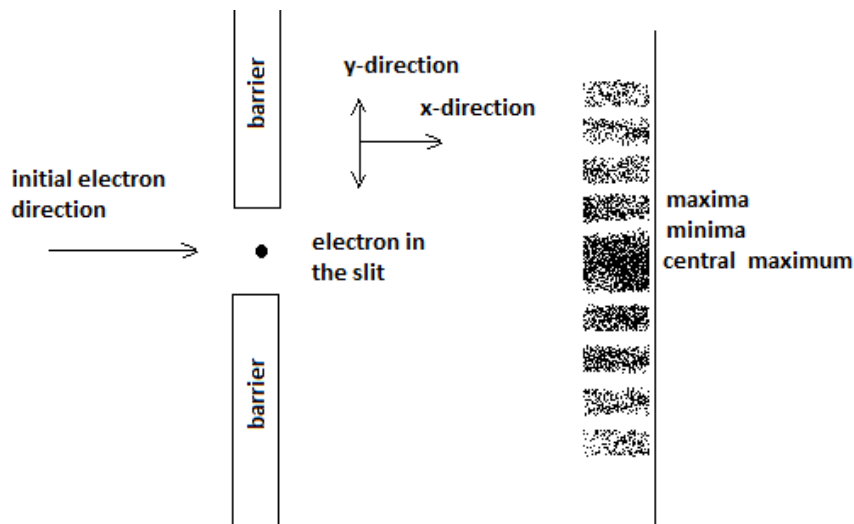

The best explanation of this observation is:

- A** Electrons passing through the slit have high uncertainty in their y-direction location inside the slit. By Heisenberg's uncertainty principle there must be a large uncertainty in their momentum in the forwards (x-direction). This produces the diffraction pattern, seen on the screen.
- B** Electrons passing through the slit have little uncertainty in their y-direction location inside the slit. By Heisenberg's uncertainty principle there must be a large uncertainty in their momentum in the sideways (y-direction). This produces the diffraction pattern, seen on the screen.
- C** Coulomb forces in the barrier are applied to the negatively charged electrons as they pass through the slit. This random force in the y direction accelerates the electrons in a small but random sideways direction. This is seen in the quantised groupings on the screen.
- D** Electrons passing through the slit have high uncertainty in their y-direction location inside the slit. By Heisenberg's uncertainty principle there must be a large uncertainty in their location in the forwards (x-direction). This produces the diffraction pattern, seen on the screen.

### Question 7

Two students are investigating a generator which is driven to provide power to a small motor. The generator has a split ring commutator which connects the output voltage to terminals M and N. Wires are then used to connect the generated voltage from M and N to the terminals of the motor at P and Q. The connections at M and N are also to a split ring commutator. See **Figure 4**.

Wires are then used to connect the generated voltage from M and N to the terminals of the motor at P and Q. The connections at M and N are also to a split ring commutator.

See **Figure 4**.

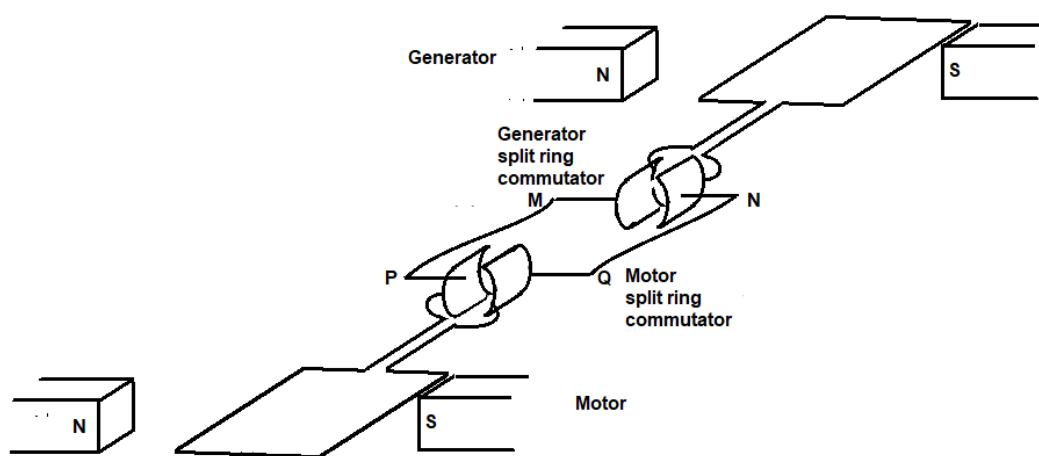

**Figure 4** The generator and motor are on separate axles. The devices share an electrical connection.

The motor is a DC motor. The students discuss whether the motor also needs a split ring commutator given there is one on the generator. The correct decision and reason is:

- A** The motor needs a commutator because the generator's commutator converts its AC output voltage to DC, and a DC motor needs to have its current switched each half cycle.
- B** The motor needs a commutator because the generator's commutator converts its DC voltage to AC, and this current needs to be switched to a continuous DC voltage to supply the DC motor.
- C** The motor doesn't need a commutator, because the generator's commutator has already switched the current to DC in each half cycle, just as the motor requires for ongoing rotation.
- D** The motor doesn't need a commutator, because the generator's commutator has switched the current to AC which is reversed in each half cycle, just as the motor requires for ongoing rotation.

### Question 8

In a laboratory experiment, a low friction trolley carrying a total mass of 5.0 kg collides with a second unloaded trolley, mass 2.5 kg. The second trolley was stationary.

In the impact the second trolley was accelerated and moves off ahead of the first, which slowed down during the impact.

Each trolley has a change in its velocity.

Friction can be ignored in this situation.

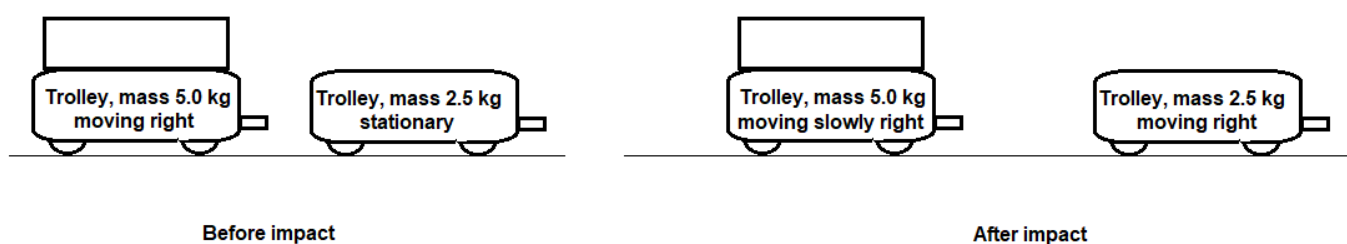

**Figure 5** The two trolleys before and after the impact.

Considering the motion of the trolleys in this situation, select the best statement describing the change in their motion.

- A** The force on the first trolley is equal and opposite to the force on the second trolley.
- B** The magnitude of the acceleration of the first trolley is equal to the magnitude of the acceleration of the second trolley.
- C** The change in velocity of the first trolley is equal to the change in velocity of the second trolley.
- D** The change in velocity of the first trolley is twice the change in velocity of the second trolley.

**Question 9**

In **Question 8**, the average force  $F_{\text{on the second trolley, by the first}}$  was 75 N and operated over 0.10 m. What was the net work done on the system during the impact?

- A** 0 J
- B** 7.5 J
- C** 15.0 J
- D** 22.5 J

**Question 10**

In a 100 m sprint race, two timing methods were used. Firstly the start was timed manually and the finish electronically. In the second both the start and the finish were timed electronically.

Researchers expected that the manual timing would produce a greater random spread of results than the all electronic method.

They found, that the first method produced slightly shorter times, than the second using only electronic timing. They concluded that:

- A** The results were actually spread as predicted. The action of starting the stop watches was random and this was appearing as the error in the timings.
- B** The race timers did not know when the race pistol would fire and their timings were all delayed in a systematic error, of the delay in their response time to the start of the race.
- C** The race timers did not know when the race pistol would fire and their timings were all affected in a random error in starting the timing, which lengthened the race times recorded.
- D** The timers were watching the starter carefully and anticipating the firing of the starting pistol. This early start to the timing produced the systematic error.

### Question 11

In an investigation of total internal reflection a beam of white light passes into a semi-circular prism. At the flat surface the beam splits. Some of the beam is totally internally reflected, some is refracted. The beam passing out of the flat side of the prism has a different colour to that which is reflected. An observer describes the coloured beams as “red” and “blue”.

The white beam struck the flat surface at  $37^\circ$  from the normal.

Note: index of refraction for red is less than the index of refraction for blue light

The beams are shown in **Figure 6** below.

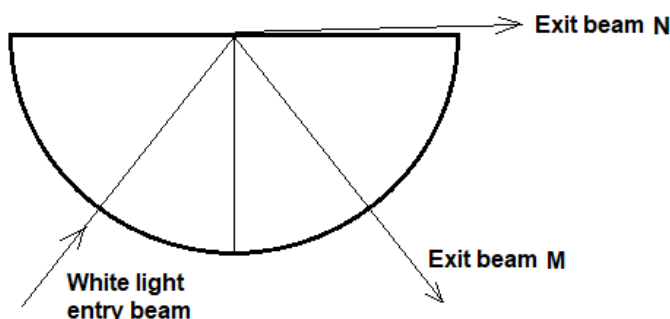

**Figure 6** The split beams seen in a total internal reflection experiment.

In this experiment, the observations show that:

Select the best answer.

- A** Beam N is “blue” and the index of refraction is 1.66
- B** Beam N is “red” and the index of refraction is 2.30
- C** Beam N is “red” and the index of refraction is 1.66
- D** Beam N is “blue” and the index of refraction is 2.30

### Question 12

Some systems of street lighting use mercury vapour lamps rather than incandescent or other lighting.

Such a street light is shown in **Figure 7**. These lights have now largely been removed and replaced with more efficient LED lighting.

These mercury vapour lamps have a bluish tinge.

**Figure 7** Mercury vapour street light Ewing, New Jersey.

Famartin - Own work, CC BY-SA 4.0,  
<https://commons.wikimedia.org/w/index.php?curid=36985606>



The light emitted by energised mercury vapour lights as used in street lighting differs from ordinary incandescent white light in several ways. How does the light production differ? Select the best statement.

- A** the filament of a the globe producing white light is coated in tungsten, while that of the mercury lamp is a mercury alloy. The difference in surfaces changes the colouring of the light. Both are incandescent.
- B** the light from a mercury vapour lamp is generated by specific electron transitions, while that of incandescent white light is produced by heat randomly accelerating charges and producing random wavelength photons.
- C** the light from a mercury vapour lamp is polarised and coherent when emitted from the mercury vapour. It is the most basic form of laser light. In contrast, white light is non-polarised and incoherent when produced in the heated filament.
- D** the light from both sources is generated by acceleration of charge, but the mercury vapour light is stronger in the violet end of the spectrum, producing significant UV light. The incandescent white light produces more infra-red light. There are more extreme accelerations producing the light in the mercury lamp than in incandescent white light.

**Question 13**

A small AC generator is forced to commence rotating. The output voltage was measured on an oscilloscope screen.

Select the most likely result to be seen, from the voltage time diagrams below.

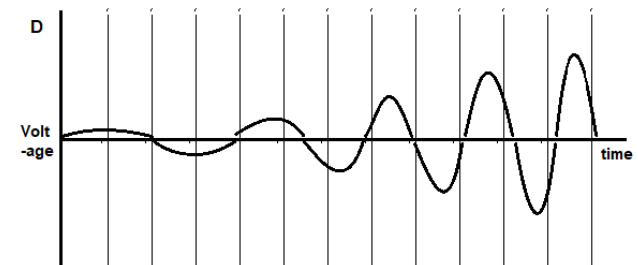
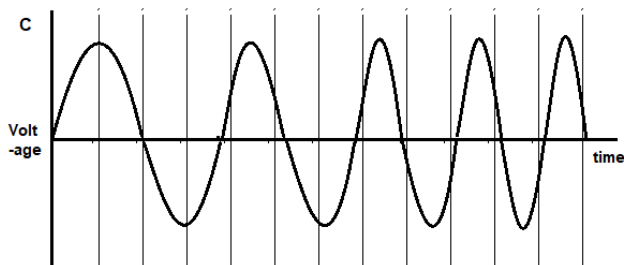
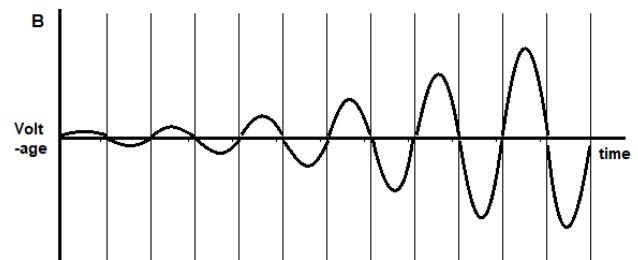
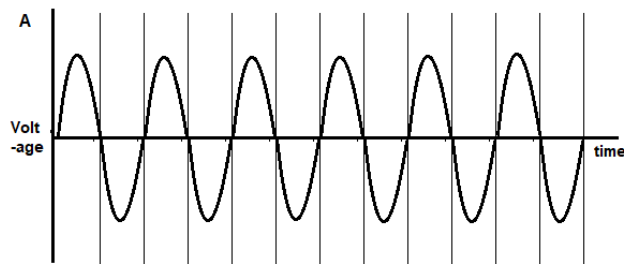



**Question 14**

An inverter is operating by converting voltage from a storage battery to 30 V AC. This voltage is then changed to 240 V AC in a transformer.

The design of the transformer is shown in **Figure 8** below.

**Figure 8**

The input winding of the transformer has 400 turns.

The two windings are linked with a transformer iron core.

Diagrams are not to scale.

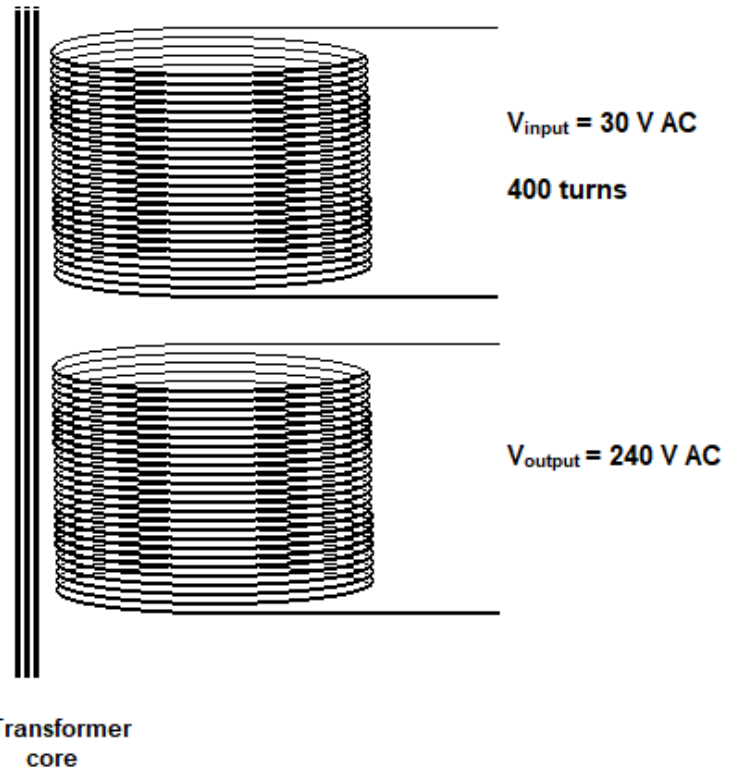

Determine the number of winding turns needed to give an output voltage of 240 V AC. In the table below, identify the primary and secondary windings. Identify the correct number of turns on the output winding.

	Input Winding	Output Winding	Output Winding Turns
<b>A</b>	primary	secondary	50
<b>B</b>	secondary	primary	50
<b>C</b>	secondary	primary	3200
<b>D</b>	primary	secondary	3200

**Question 15**

The AC power from the system in **Question 14** will be transferred by a cable from one building to another over a distance of 20 m. At this point it delivers power to a load of  $15.4 \Omega$ .

The ground between is rock and ice. To reduce the risk of ice movement damaging the cable, it is designed with a resistance which generates some heat in the wire and prevents ice gripping the cable.

The cable has a total resistance of  $1.2 \Omega$ .

See **Figure 9**.

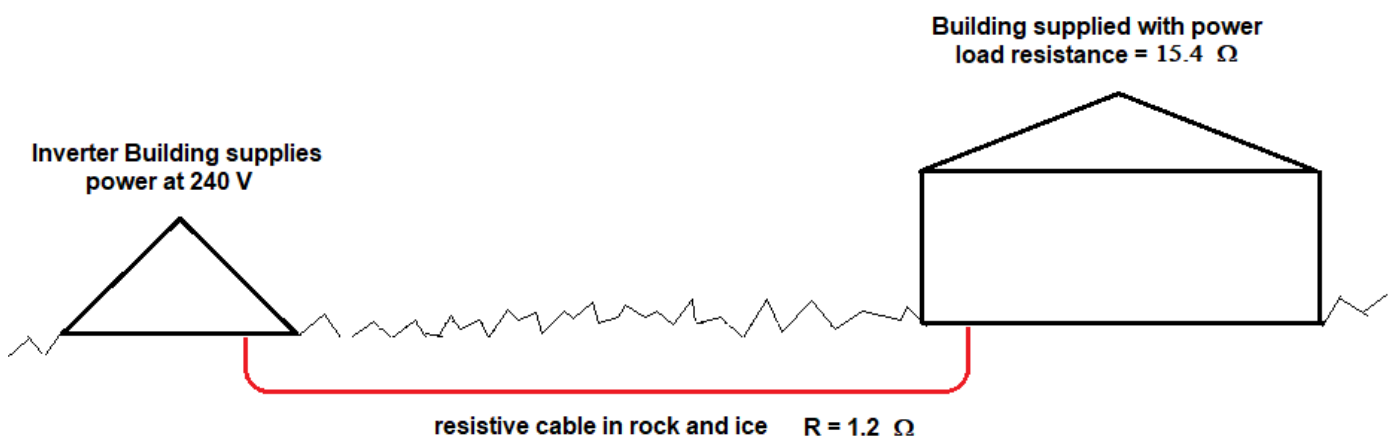

**Figure 9** shows the wire connecting the two buildings in a risky environment.

Under full current conditions, what power is delivered in the wire to protect it from damage?  
Choose the best answer.

- A** 250 W
- B** 290 W
- C** 3430 W
- D** 3740 W

### Question 16

It is sometimes suggested that thermal generators could be designed to be more efficient as a way to reduce but perhaps not eliminating carbon dioxide production.

One method proposed is the use of a magneto-hydrodynamic (MHD) generator. This generator operates at a much higher temperature and the waste heat then drives a conventional turbine. This means that the heat energy can be used twice. Heat for this generator could be from fossil fuels, hydrogen or nuclear.

In the MHD generator, a charged gas at high temperature flows through a tube where there is a magnetic field directed across the direction of motion of the charged gas.

A DC voltage is collected on the electrodes on the side of the tube. In this case the magnetic field is directed down. See **Figure 10**.

**Figure 10** The layout of an MHD generator using negatively charged gas.

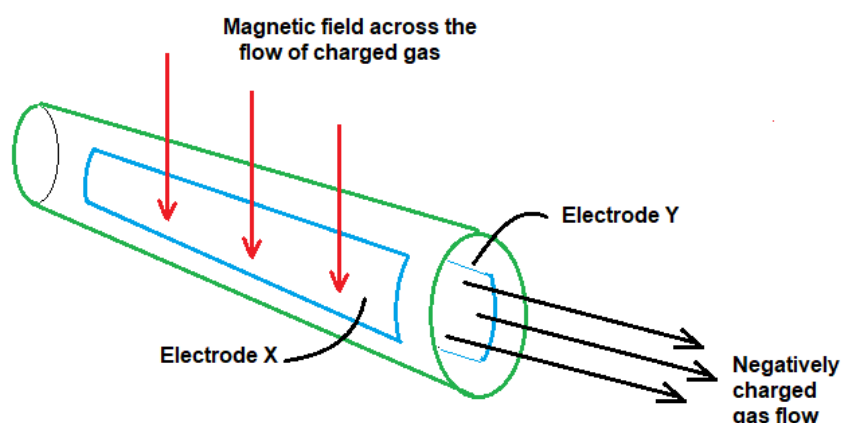

The voltage on Electrode X will be:

- A** negatively charged because the magnetic field rotates the gas molecules to orientate the negative towards Electrode X
- B** negatively charged because the right hand rule shows the negative charge is forced towards Electrode X.
- C** positively charged because the magnetic field rotates the gas molecules to orientate the negative charge towards Electrode Y
- D** positively charged because the right hand rule shows the negative charge is forced towards Electrode Y.

**Question 17**

Earthquakes involve the movement of several types of waves. One type is called the S wave which is a transverse wave. Another is a P wave which is longitudinal. When the waves arrive they can deliver accelerations comparable to that produced by the Earth's gravity.

These waves are generated when fault lines in the Earth's crust slip or slide.

In **Figure 11** such damage can be seen.



Photo Martin Luff BY-SA/2.0  
The Darfield earthquake of September 2010 caused much damage in Christchurch, 40 km away. Vertical movement pushed this storm drain up through the road in Brooklands (northern Christchurch NZ).



This 40 m long wall of the Christchurch museum “stretched” 100 mm as its foundations separated during the 2010 earthquake.

Author's photo

**Figure 11** Earthquake damage in Christchurch 2010.

**Question 17 (continued)**

Considering these two types of earthquake waves, select the best statement.

- A** The transverse S waves move the Earth's surface vertically up and down carrying energy, but the longitudinal P waves move the ground physically away from the earthquake source. It is this second movement which dislodges foundations and does major damage.
- B** The longitudinal P waves move the Earth's surface horizontally back and forth transferring energy, but the transverse S waves move the ground physically up or down leaving the surface levels changed and matter transferred. It is this second movement which dislodges foundations and does major damage.
- C** Both S and P waveforms transfer energy, but they do not transfer matter. The disruption and damage of the earthquake is caused by buildings and the ground structure failing during these accelerations. Rock is deformed and damaged by the delivery of this energy. This produces permanent changes in the land surface, in addition to changes produced at the fault-line movement.
- D** Both S and P waves transfer matter. This movement and the speed at which the movement is made causes damage all the way from the earthquake centre where rock was thrust up from inside the earth's crust. Energy transfer is not an issue in transverse or longitudinal waves.

**Question 18**

In **Figure 12** below, the photo electric data of four different metals is shown. The graphs cover a range of frequencies up to  $1.0 \times 10^{15}$  Hz and show the relevant maximum kinetic energies.

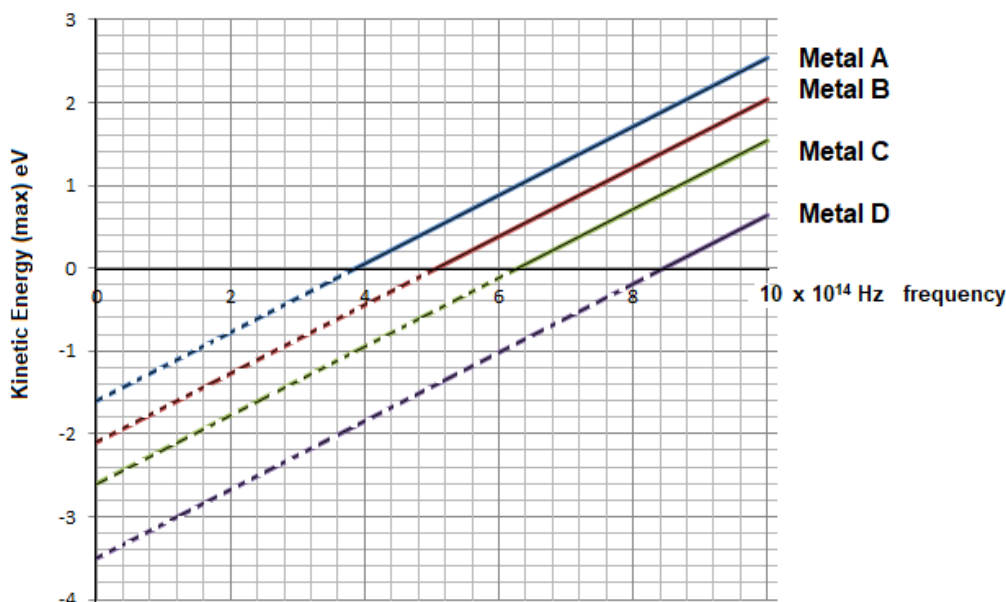

**Figure 12** The kinetic energy – frequency graph for four different metals

Consider the work functions, the cut-off frequencies and the maximum kinetic energy of electrons released by light with frequency  $8.0 \times 10^{14}$  Hz, for these four metals, A, B, C and D. Select the statement, which best identifies these properties for these metals.

The **Answer** letters correspond to the metal letters.

metal, answer	work function eV	cut-off frequency Hz	maximum kinetic energy at $8.0 \times 10^{14}$ Hz (eV)
<b>A</b>	-1.6	$3.9 \times 10^{14}$	1.7
<b>B</b>	-2.1	$5.1 \times 10^{14}$	1.2
<b>C</b>	2.6	$6.3 \times 10^{14}$	0.7
<b>D</b>	3.5	$8.4 \times 10^{14}$	-0.2

**Question 19**

In an investigation of two projectiles, one is dropped from a 10 m height and allowed to fall the ground.

Simultaneously, a second projectile is launched upwards with sufficient velocity to just reach the height of 10 m.

See **Figure 13**.

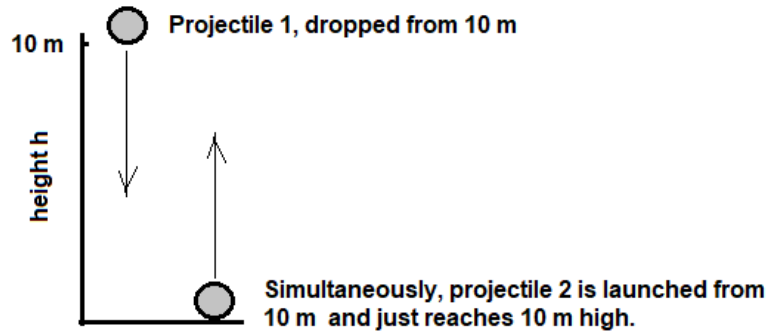

**Figure 13** shows the motion of the two projectiles which pass each other in vertical motion. The directions of their movements are shown.

The distance time graphs were recorded for both motions. The intersection of the graphs shows the moment when the two projectiles pass each other.

Select the graph which is closest to that expected for these movements?

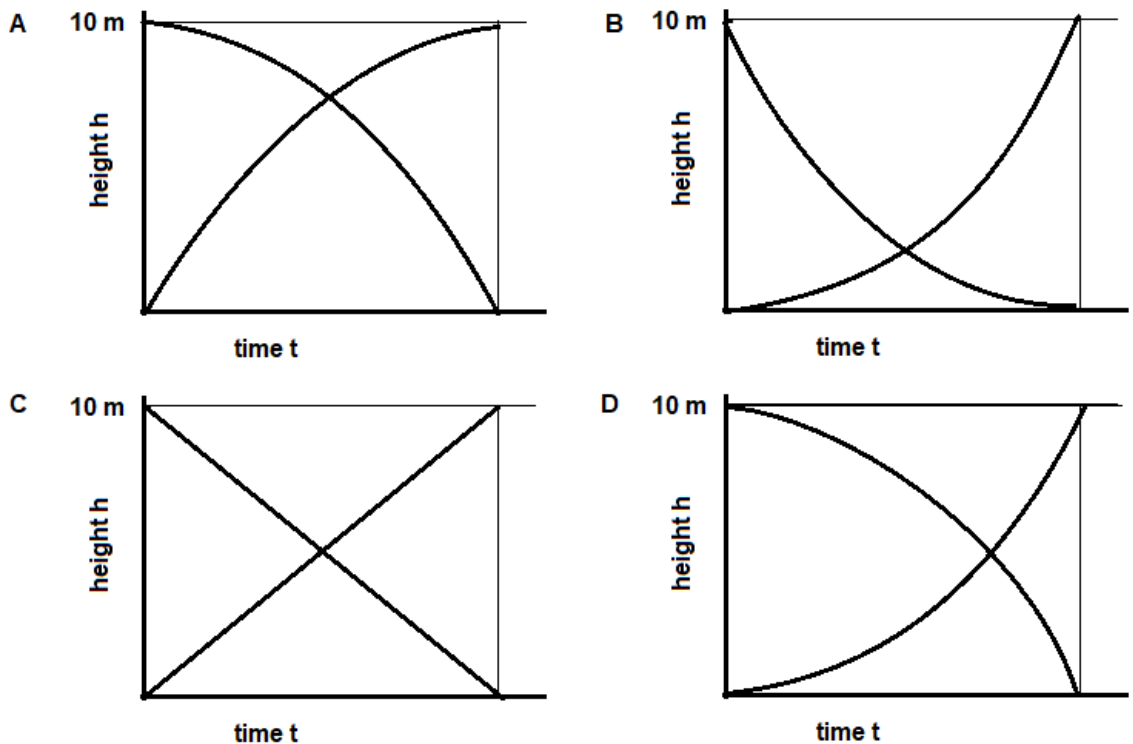



**Question 20**

When a 20 kg mass was suspended from a spring, it stretched 0.040 m.

The 20 kg mass was then supported on the spring at the point of zero extension. The mass was then allowed to drop, with its fall only restrained by the spring.

See **Figure 14**.

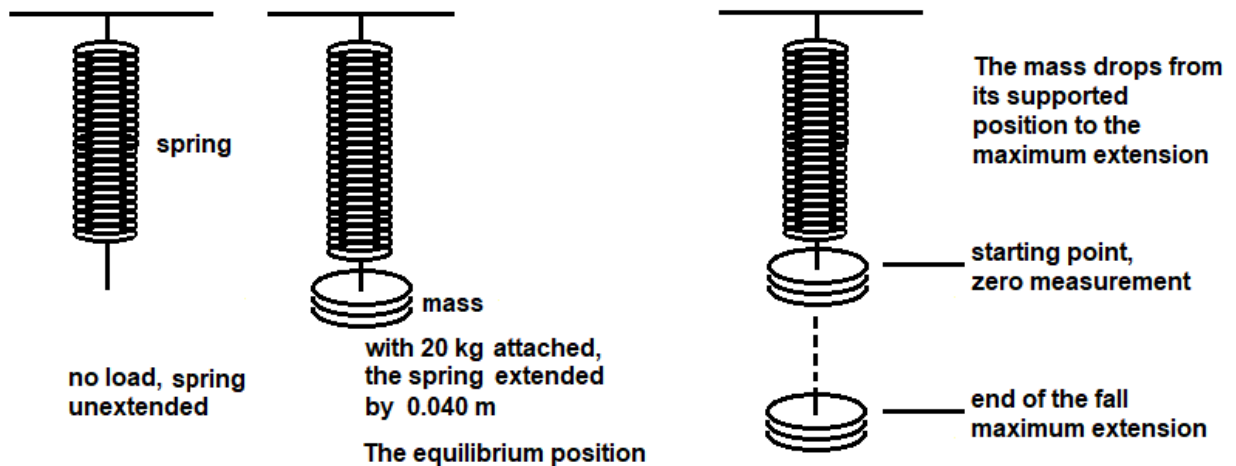

**Figure 14** shows the spring, loaded with 20 kg, which was stretched by 0.040 m at equilibrium. It then is let drop from the zero extension to the maximum extension of the spring.

How far does the spring stretch before stopping the mass momentarily, if the mass is allowed to drop from the unloaded extension position?

Select the best answer.

- A 0.000 m
- B 0.040 m
- C 0.080 m
- D 0.012 m

**End of Section A**



## SECTION B

### Instructions for Section B

Answer all questions in the spaces provided, Write using a blue or black pen.

Where an answer box is provided, write your final answer in that box.

If an answer has a unit printed in it, give your answer in that unit.

In questions where more than one mark is available, appropriate working **must** be shown.

Unless otherwise indicated, the diagrams in this book are **not** drawn to scale.

Take the value of  $g$  to be  $9.8 \text{ m s}^{-2}$  unless otherwise specified.

### Question 1 (5 marks)

Fredericka frog is sitting on the bank beside a pond. Fredericka is  $0.10 \text{ m}$  above the water line. She intends to leap to a lily pad on the water surface,  $0.78 \text{ m}$  away from her starting position. However there are reeds in the way which she must leap to reach the lily pad.

She will need to be travelling horizontally at the point  $0.35 \text{ m}$  from her start and at height  $0.30 \text{ m}$  above the water, to avoid the reeds. See **Figure 15**.

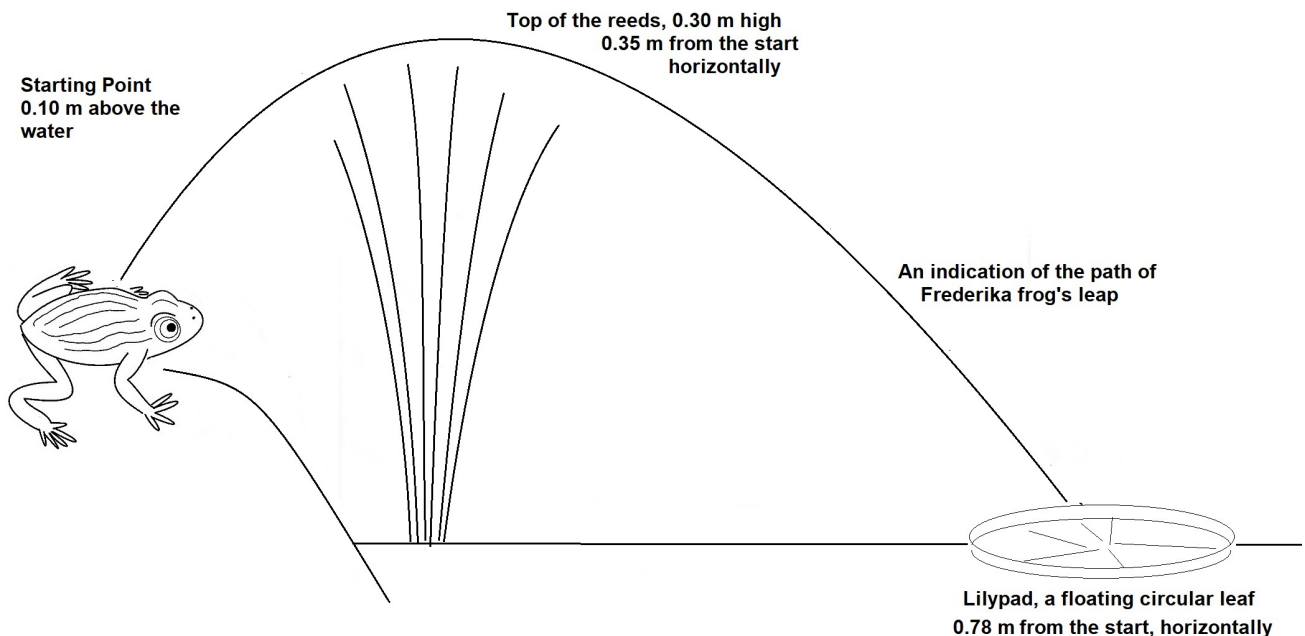

**Figure 15** shows the location of the frog as it prepares to leap to the lily pad.

**Question 1 continued**

**a**

**(2 marks)**

What horizontal velocity will Fredericka need to pass over the reeds, travelling horizontally at that point? Show your working.

$\text{ms}^{-1}$
------------------

**b**

**(2 marks)**

What total time will be taken in the leap? Show your working.

s
---

**c**

**(1 mark)**

Show that Fredericka does land on the lily pad.  
You must show your calculations.

**Question 2 (8 marks)**

Students were investigating the strength of a magnetic field surrounding a current carrying wire. The current in the wire was set at 10.0 A. The layout is shown in **Figure 16**.

The magnetic detector was aligned so that the field measurements did not include the Earth's magnetic field strength or other stray fields. It was understood that the recording of the field strength was very accurate, using the blue sensor.

The blue magnetic sensor was moved along the axis, to the right. Radius measurements from the centre of the wire were recorded and the magnetic field at that point was then determined.

The students expected to show a linear relationship between  $1/\text{Radius}$  and the strength of the magnetic field.

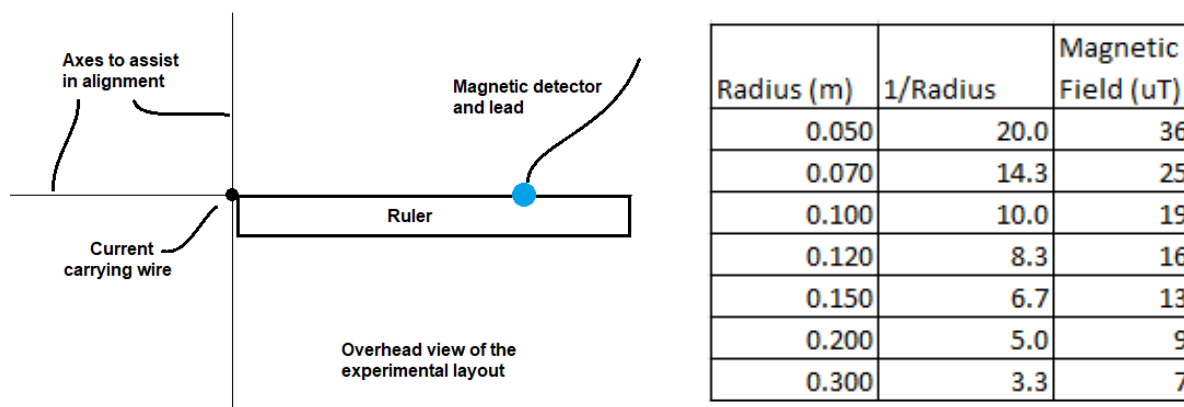
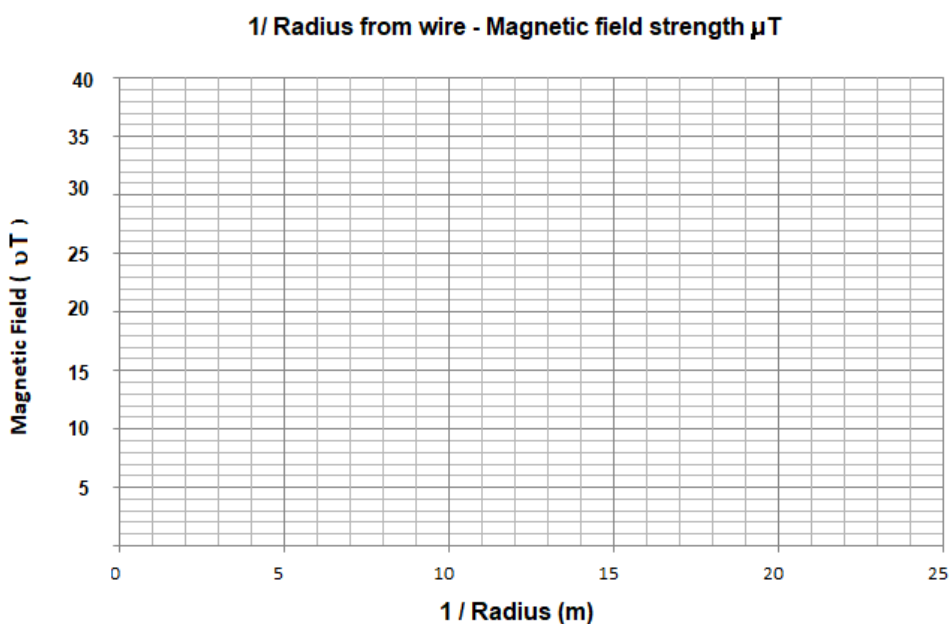

**Figure 16** The experimental setup of equipment and the data collected.

**a**

**(2 marks)**

Plot the collected data of  $1/\text{Radius}$  – magnetic field strength, on the graph below. Show a line of best fit to describe the data.



**Question 2 continued**

**b**

**(2 marks)**

Which variable is the independent variable in this experiment?

Which variable is the dependent?

Explain your choice.

.....

.....

.....

**c**

**(2 marks)**

The students are concerned that while the graph was expected to direct to the origin, the line of best fit does not appear to begin there. There is a small positive intercept on the (magnetic field) y-axis. Realigning the line of best fit to the origin suggests many data errors.

What sort of an uncertainty have they discovered?

What steps could they take in reviewing the experiment to possibly deal with this problem?

.....

.....

.....

**d**

**(2 marks)**

Reviewing the data, how would you correctly assess the experiment's results for precision and for accuracy, explaining your decision?

.....

.....

.....

**Question 3 (5 marks)**

In a large hall, a mirror ball is hanging on a light axle, from the ceiling.

A wind blows through the hall and sets the mirror ball swinging in a circular path at  $19^\circ$  from the vertical.

The radius of the rotation is 0.22 m

This is shown below in **Figure 17**.

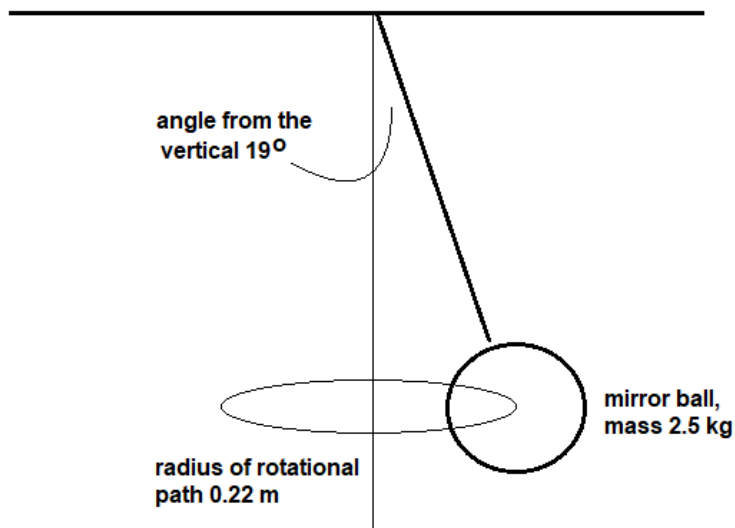

**Figure 17**

The mirror ball is forced to rotate in a circle, radius 0.22 m

**a**

**(3 marks)**

What is the period of rotation of the mirror ball?

Show your working.

s
---

**b**

**(2 marks)**

What load does the 2.5.kg mirror ball impose on the supporting axle while following this circular path? Show your working.

N
---

**Question 4 (6 marks)**

A robotic space explorer arrived at a distance solar system, chose a planet and placed itself in orbit around it as it began its investigation.

The first measurements were about the explorer's path.

The orbital period was  $1.58 \times 10^5$  s.

It was in orbit  $7.80 \times 10^7$  m above the surface of a planet, with a  $1.20 \times 10^4$  km in radius.

This is shown in **Figure 18**.

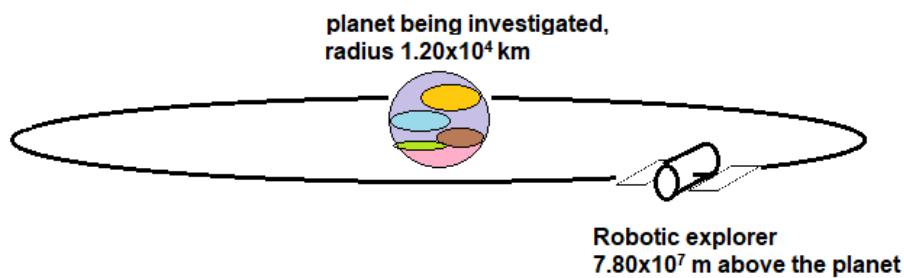

**Figure 18** The robotic explorer in orbit around the planet which was being investigated.

**a**

**(2 marks)**

The explorer used this data to determine the mass of the planet.

What is the mass of the planet? You must show your working.

kg
----

**Question 4 continued**

**b**

**(2 marks)**

What is the strength of the gravitational field at this orbital position?  
You must show your working.

$\text{N kg}^{-1}$
--------------------

**c**

**(2 marks)**

The robotic explorer determined that it needed to change its orbital height by  $1.0 \times 10^7$  m. At the new position the strength of gravity was  $0.180 \text{ N kg}^{-1}$ . At these heights above the planet, the change in the gravitational field strength can be regarded as linear over this height change. The robotic explorer has mass 2300 kg.

What is the magnitude of the change in the explorer's gravitational potential energy?

$\text{J}$
------------

**Question 5 (5 marks)**

The photoelectric experiment supports a particle model of light unlike many other light investigations. In the photoelectric experiment there is a threshold frequency, below which no electrons are emitted.

**a (2 marks)**

How does this observation of a threshold frequency support a particle model and what would be expected of the wave model of light in this context if it was correct?

.....

.....

.....

.....

In a particular investigation, the threshold frequency was determined to be  $5.2 \times 10^{14}$  Hz. At  $6.6 \times 10^{14}$  Hz, the photo-electron current was brought to zero by an opposing voltage of 0.55 V. See **Figure 19**.

**Figure 19** shows the experimental layout and some data from the investigation.

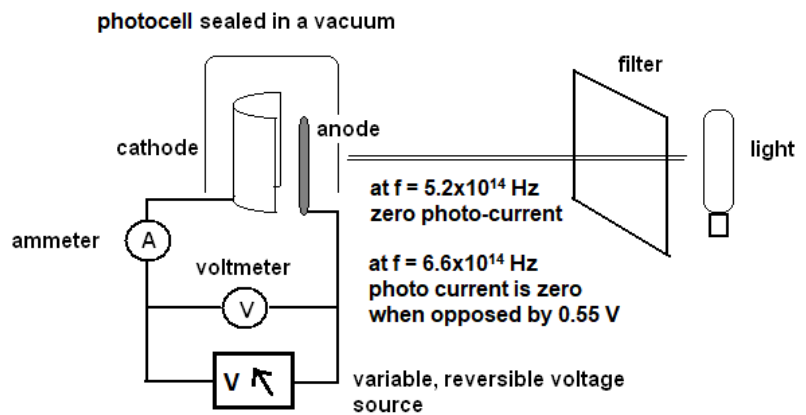

**b (3 marks)**

What is the experimental value of Planck's constant found from these observations?  
Show your working.

J s
-----



**Question 6 (5 marks)**

In an investigation of diffraction through circular gaps, investigators plan to produce a pattern using electrons which have been accelerated by 2.0 V.

The electrons pass through a gap  $1.4 \times 10^{-7}$  m in diameter

**a**

**(2 marks)**

What is the wavelength of these electrons?

Show your working.

m
---

Under appropriate conditions a diffraction pattern, similar to that seen for the electrons, could be formed using photons. See **Figure 20**.

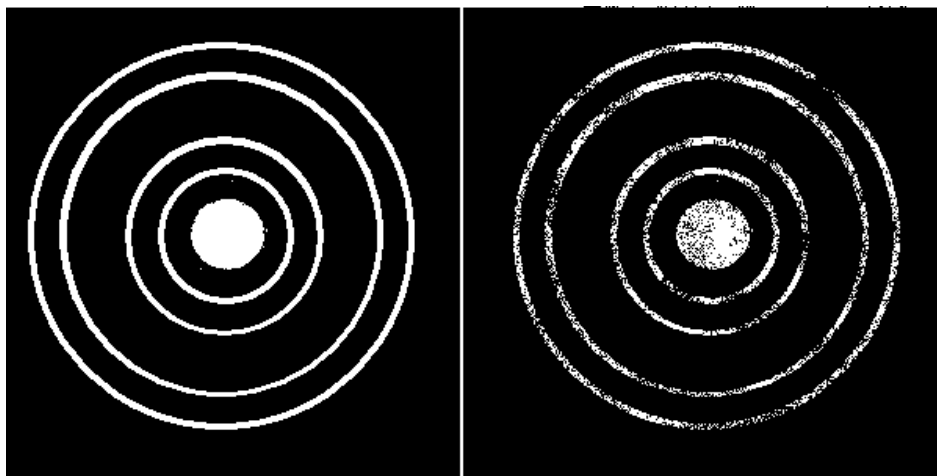

**Figure 20** A similarly structured diffraction pattern formed with photons, left and electrons right, passing through circular holes. These patterns are not identical in size.

**Question 6 continued**

**b**

**(2 marks)**

The investigators use photons with wavelength 430 nm which pass through a different set of circular holes. The pattern is to have the same form as that produced by electrons in **part a**.

What size circle would the investigators expect to use to create the same structure of diffraction pattern, using this wavelength of light? Show your working.



**c**

**(1 mark)**

What is the one feature shared by these two diffraction systems?

.....

**Question 7 (5 marks)**

A new relativistic speed space ship is being tested for its performance.  
It was designed with a length of 800 m.

While under test, the Earth based design team observe that the length is less, than that in the design specifications. It is measured to be 450 m.

**Figure 21**

Some features of the spaceship seem different to those in the design specifications.

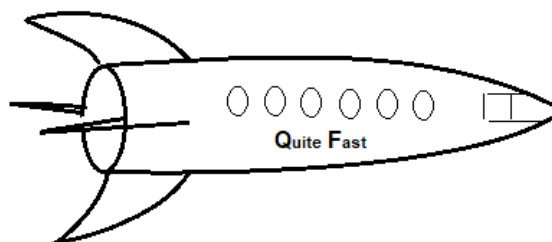

**a**

**(2 marks)**

Give a basis for the observation that the length is observed to be less, than in the design.  
Relate this to a relevant Einsteinian postulate.

.....

.....

.....

**b**

**(2 marks)**

What was the spaceship's speed when the shorter length observation was made?  
Answer correct to 3 significant figures. Show your working.

$\text{m s}^{-1}$
-------------------

**Question 7 continued**

**c**

**(1 mark)**

What is the kinetic energy of the 15000 tonne space ship at this speed?

J
---

**Question 8 (4 marks)**

Observers have measured the average lifetime of muons in the laboratory and know that it is  $2.2 \mu\text{s}$ . After this time, muons decay into different particles.

In the upper atmosphere where muons are created in collisions, they travel down through the atmosphere at  $0.99c$ . This is a Lorentz factor of 7.1.

**a** **(1 mark)**

At this speed, and with such a short lifetime, the muons should only be able to travel briefly through the atmosphere. However, they are observed travelling for much longer times before they decay. Why are their lifetimes in the atmosphere so much longer than in the laboratory?

.....  
.....

**b** **(1 mark)**

For Earth based observers, how long do muons exist before decaying while travelling through the atmosphere?

$\mu\text{s}$
---------------

**c** **(1 mark)**

From the muon's frame of reference, the distance travelled would be expected to be 650 m before they decay. Why can they travel so much further?

.....  
.....

**d** **(1 mark)**

How far will a muon reference frame observer record the atmosphere travelling towards the muon?

$\text{m}$
------------

**Question 9 (7 marks)**

A sound box with a resonant wire was being used in an analysis of sound waves. The resonant wire was put under tension by a hanging weight. See **Figure 22** below.

**Figure 22**  
The tensioned string on a resonant box

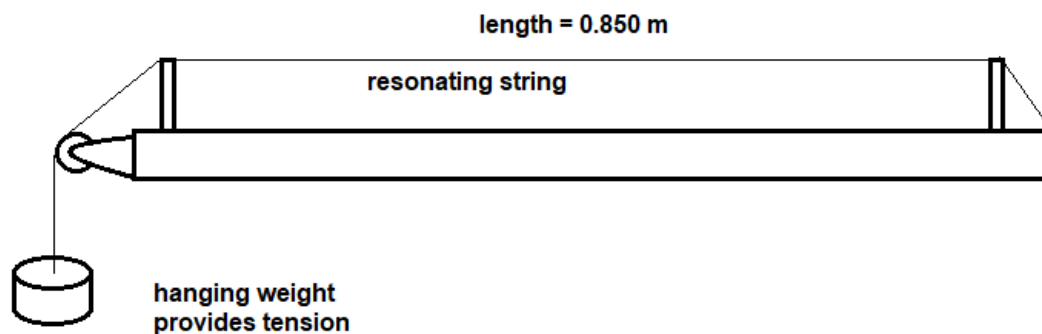

The wire is plucked so that it resonates at its fundamental frequency. The sound wave generated in the wire travels at  $255 \text{ m s}^{-1}$ .

**a** (1 mark)

What is the frequency of the fundamental first harmonic generated in the wire?

Hz
----

**b** (2 marks)

The string is plucked again, producing a third harmonic in the wire.

On the diagram below, sketch the waveform in the wire at two different times.

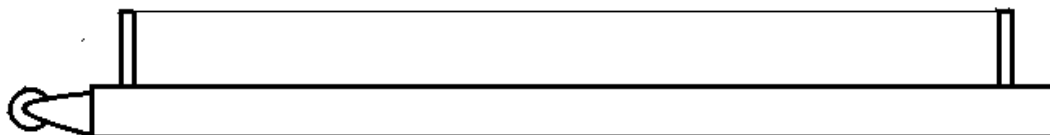

**Question 9 continued**

**c**

**(2 marks)**

How does this wave travel and form its shape in the wire?

.....

.....

.....

.....

**d**

**(2 marks)**

How does it differ from the waves which carry sound through the air?

.....

.....

.....

.....

**Question 10 (8 marks)**

An experimental generator has a uniform magnetic field of 0.25 T and a rotating coil of 300 turns. The output is collected from the coil through two slip rings and the output is recorded on a voltage data logger which records as a positive value the average output emf in a specified section of the rotation of the coil.

Length YZ is 0.050 m and WX is 0.060 m.

The coil rotates at 40 Hz. The generator layout is shown in **Figure 23**.

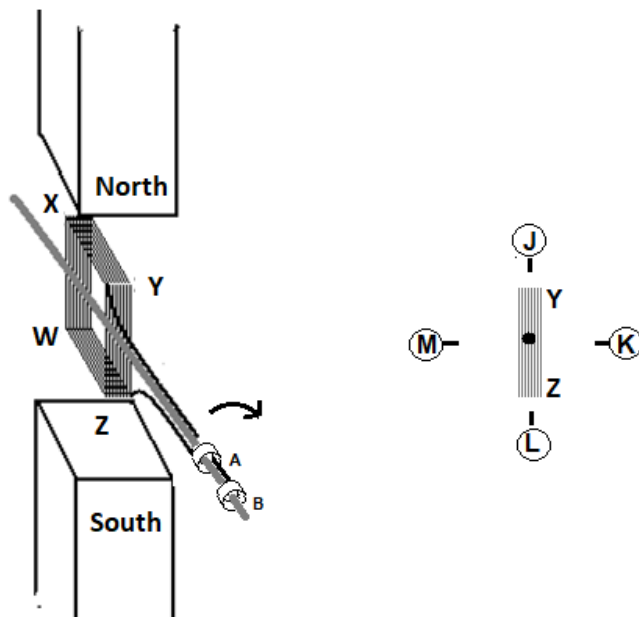

**Figure 23**

On the left is the experimental motor with its slip rings, A and B.  
 On the right is an end view of the coil, showing the length YZ. It shows four alignment points, J, K, L and M. In this view the end Y is aligned with point J.

**a**

**(1 mark)**

What is the maximum flux which passes through the coil?

Wb
----



**Question 10 continued**

**b**

**(2 marks)**

In one investigation, voltage generated is measured when the coil rotates a quarter turn, with point Y moving from J to K.

What is the average emf recorded in this quarter turn?

V
---

**c**

**(2 marks)**

On the axes provided sketch the graph of the flux through the coil as it moves from position J to K.

Show a peak value for the flux. Regard the magnitude of the flux as positive.

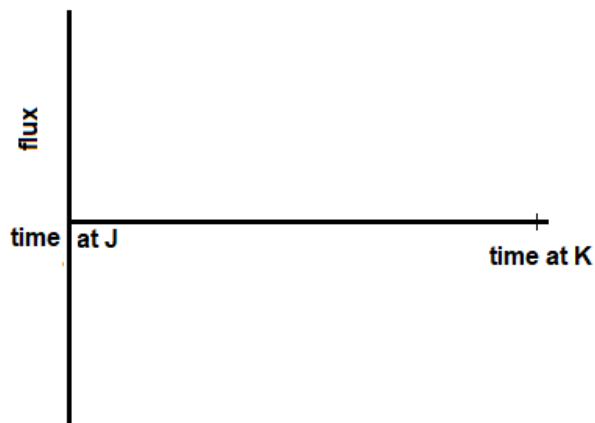

**d**

**(1 mark)**

The experimental process is repeated, but this time the emf is measured as Y rotates from M to K.

What is the average emf recorded in this half turn?

V
---

**Question 10 continued**

The generator is now changed, to use a split ring commutator, instead of the slip rings.  
 See **Figure 23**.

**Figure 23**

The generator now has a split ring commutator

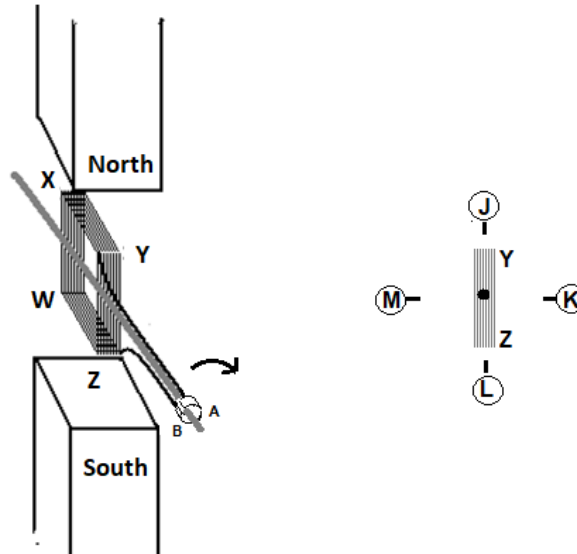

e

**(2 marks)**

The procedure is repeated, moving the end point Y from M to K while using the split ring commutator.

What is the emf recorded in this half turn?

V

**Question 11 (2 marks)**

Researchers working on fusion energy programs have considered an alternative approach using laser or accelerator controlled processes, rather than reactor based reactions. While raising new problems to solve, it leads to quite different solutions to those usually proposed for fusion power.

A proposed reaction could be:

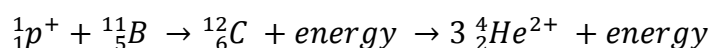

A proton strikes a Boron-11 atom. It is absorbed briefly into the nucleus, initially forming Carbon-12 but the nucleus is so energised that it nearly immediately shatters into three alpha particles (Helium-4 nucleus)

mass of a proton  $1.673 \times 10^{-27}$  kg

mass of Boron-11  $1.8281 \times 10^{-26}$  kg

mass of an alpha particle (He-4)  $6.645 \times 10^{-27}$  kg

**a**

**(2 marks)**

What is the total energy release in this reaction forming three alpha particles from a proton and boron? Show your working.

J
---

**Question 12 (5 marks)**

A voltmeter which records AC voltage as RMS was used to measure the output from a transformer.

The input voltage to the transformer reads 12.4 V. The transformer was a step-up design in a ratio 1:4.

**a**

**(2 marks)**

What would be the output voltage  $V_{\text{peak to peak}}$ ? Show your working.

V
---

**b**

**(2 marks)**

This output voltage supplies a load of  $130 \Omega$ . What power is delivered to the load?  
Show your working.

W
---

**c**

**(1 mark)**

Identify one feature of an AC supply which makes it a convenient form of electricity supply.

.....

**Question 13 (4 marks)**

Researchers were examining the trails left on film by positrons after the decay of a radio-isotope. The trails were made while controlling the path of the positron with a 0.012 T field. The positron's circular path is 2.2 cm in diameter.

The mass of a positron is the same as that of the electron and its charge is equal, but positive. See **Figure 24**

**Figure 24**

The path and direction of the as seen by the researcher.

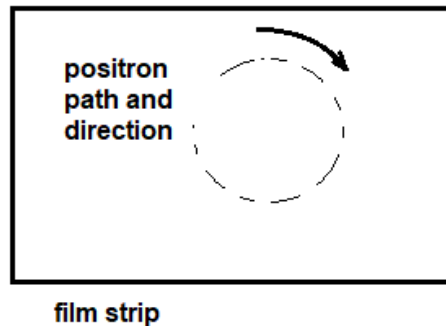

positron

The path of the ejected positron is known to be clockwise on the film.

**a** (1 mark)

What was the direction of the magnetic field relative to the researchers' view of the film?  
Explain your answer.

.....

.....

**b** (1 mark)

As the positron follows its circular path, it generates a magnetic field.  
What is its direction at the centre of the circular path?

.....

**c** (2 marks)

What is the speed of the positron? Show your working.

$\text{m s}^{-1}$
-------------------

**Question 14 (7 marks)**

A green laser ray, wavelength 550 nm was shone on a double slit, width 0.43 mm.  
A screen was placed 1.25 m from the two slits and the image was investigated.  
A series of green and black bands was seen spread across the screen.

**a** **(2 marks)**

The width of 10 green bands was measured on the screen.  
What total width would be expected for these 10 green bands? Show your working.



**b** **(2 marks)**

What would be seen on the screen if a ray of white light had been used instead?

.....

.....

.....

**Question 14 continued**

**c**

**(1 mark)**

The central antinode was identified in the pattern on the screen.

Now, considering the point of the 3<sup>rd</sup> nodal line, what is the difference in lengths of the paths from the two slits to this node? See **Figure 25**

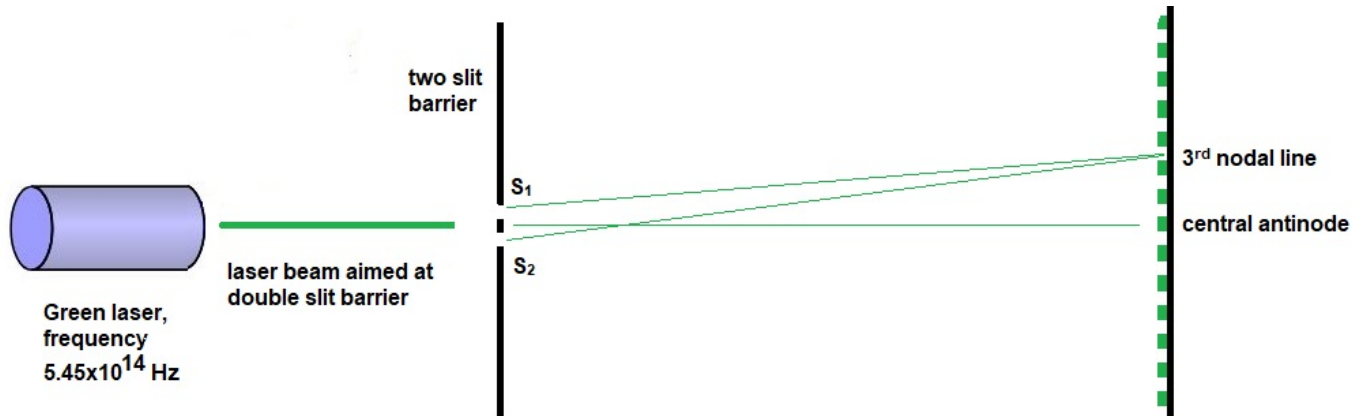

**Figure 25** The experimental arrangement showing the antinodes and nodes on the screen.

m
---

**d**

**(2 marks)**

What is the physical process which allows this length to be identified?

.....

.....

.....

**Question 15 (6 marks)**

A mercury atom has an electron energised so that it is at level  $n=4$ . See **Figure 26**.

**Figure 26**

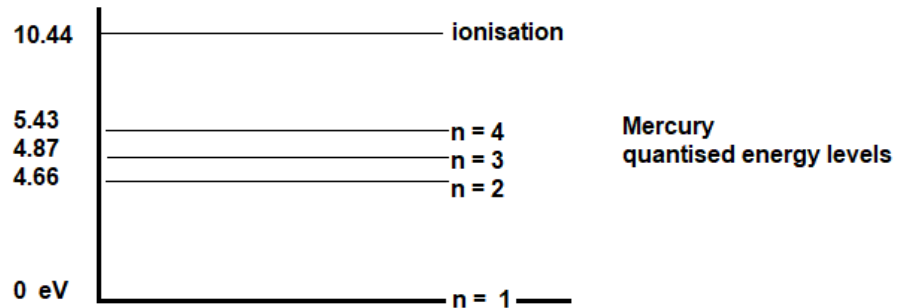

**a** (2 marks)

On **Figure 26** above, use appropriate arrow indications to show all the electron transitions between level  $n = 4$  and  $n = 1$  which will emit photons.

**b** (2 marks)

On the diagram below, sketch two wave structures which could be held by this electron at level  $n = 4$ .

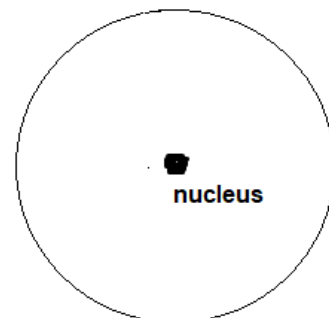

**c** (2 marks)

How does the standing wave structure of the electron around an atom show that the electron's energy must be quantised?



**Question 16 (9 marks)**

A toy roller coaster is being investigated. The trolley is forced to travel on a track, initially level, but which leads to a circular loop. After passing through the loop, the trolley continues further on a path at the original level.

The spring stores 3.4 J of energy and is able to deliver 75% of that to the trolley, mass 0.61 kg. The trolley follows a path with radius 0.15m in the circular loop.

This is shown in **Figure 27**.

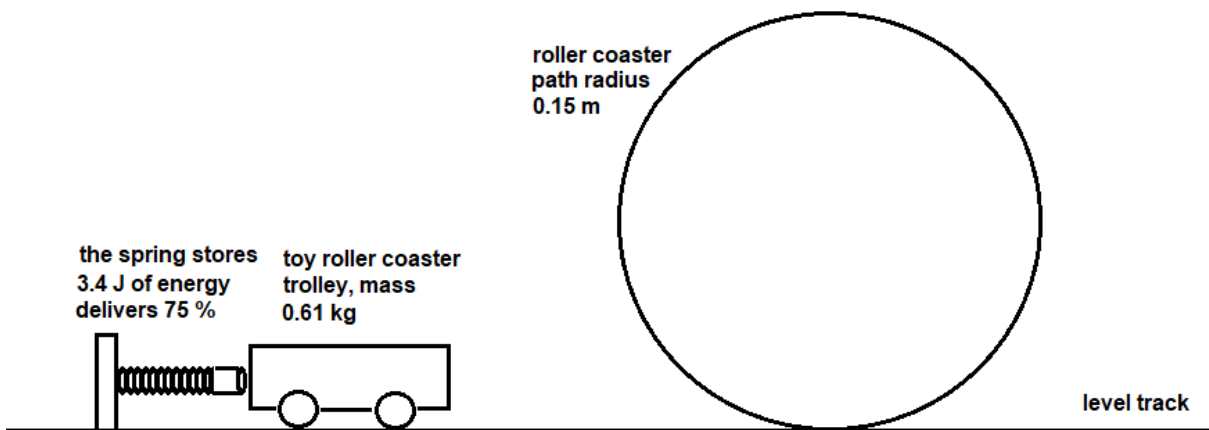

**a**

**(3 marks)**

What is the speed of the trolley at the top of the circle?  
Show your working.

$\text{m s}^{-1}$
-------------------

**Question 16 continued**

**b**

**(3 marks)**

What force does the track exert on the trolley when it is at the top of the circular track?  
Show your working.

**c**

**(1 mark)**

At what velocity would the force between the trolley and the loop drop to zero?

**d**

**(2 marks)**

If the trolley had only this speed at the top of the loop, what was the efficiency of the spring energy transfer if the spring still stored 3.4 J? Show your working.

**Question 17 (5 marks)**

Electrons, with energy 160 eV, were used in part of an electron microscope investigation.

**a** **(3 marks)**

What is the size of the smallest object which could be investigated by these electrons?

m

**b** **(1 mark)**

What physical process produces this limit?

.....

.....

**c** **(1 mark)**

If electromagnetic radiation was used to achieve similar resolution of an image of this size, what would be its energy?

eV

**Question 18 (6 marks)**

An alpha particle, travelling at  $9.60 \times 10^6 \text{ m s}^{-1}$  strikes a stationary proton. The velocity of the alpha particle drops to  $5.74 \times 10^6 \text{ m s}^{-1}$  after the impact.

The mass of the alpha particle is 3.97 times the mass of the proton.

The alpha particle has two positive charges, while the proton has one.

There are no relativistic issues involved, and there is no change in the rotation of the particles during the collision.

After the impact, both particles move in the direction of the alpha particle's original path as shown in **Figure 28**

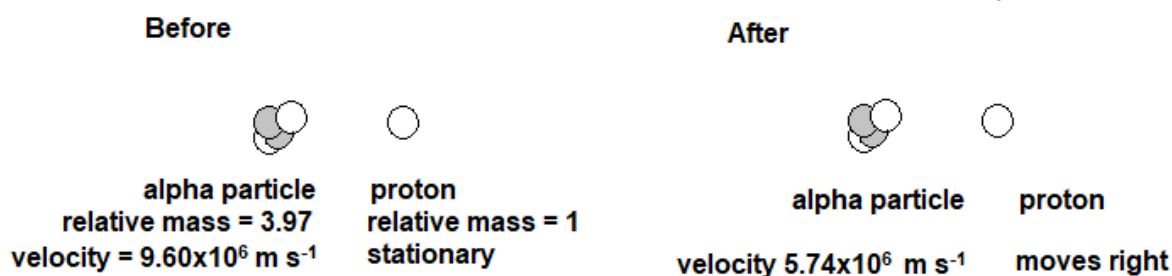

**Figure 28** The collision when an alpha particle strikes a proton.

**a** (2 marks)

What is the speed of the proton after the collision? Show your working.

$\text{m s}^{-1}$
-------------------

**b** (2 marks)

Is this collision elastic or inelastic? Show your working

**Question 18 continued**

**c**

**(1 mark)**

Why was this, the likely form of the collision?

.....

**d**

**(1 mark)**

Why was it possible to ignore relativistic effects in this question?

.....

.....

**Question 19 (5 marks)**

Photons are passed through a double slit and a diffraction pattern is observed, when only one photon is in the slit – screen region at any one time. This pattern is the same if more photons are used.

**a** **(1 mark)**

If a similar experiment was performed using only one electron at a time, what will be observed?

.....

**b** **(2 marks)**

What do these interference experiments confirm about the nature of electrons and photons in these observations?

.....

**c** **(2 marks)**

While particles like electrons and photons can show similar properties, during diffraction, they will also show differences.

Identify two differences between electrons and photons while they are both demonstrating wave properties.

.....

.....

**Question 20 (3 marks)**

We have many uses for the waves of the electromagnetic spectrum.

**a** **(1 mark)**

Identify a usage of the UHF Ultra High Frequency band, 300 MHz to 3 GHz (approximately).

.....

**b** **(1 mark)**

Which band of the electromagnetic spectrum would be chosen to sterilise air which is contaminated with water droplets containing viruses?

.....

**Question 20 continued**

**c**

**(1 mark)**

Many living organisms have the ability to sense light, using its photon behaviour, in the range of visible wavelengths, approximately 380 to 720 nm in humans. Some fish including goldfish can see UV light up to 277 nm using the extra receptors in their retinas. Goldfish can also release an enzyme which allows them to modify their red vision and see IR light at least down to 770 nm. See **Figure 29**.

**Figure 29** The vision ranges for humans shown in spectral colours, and those for goldfish with their additional ranges in white.

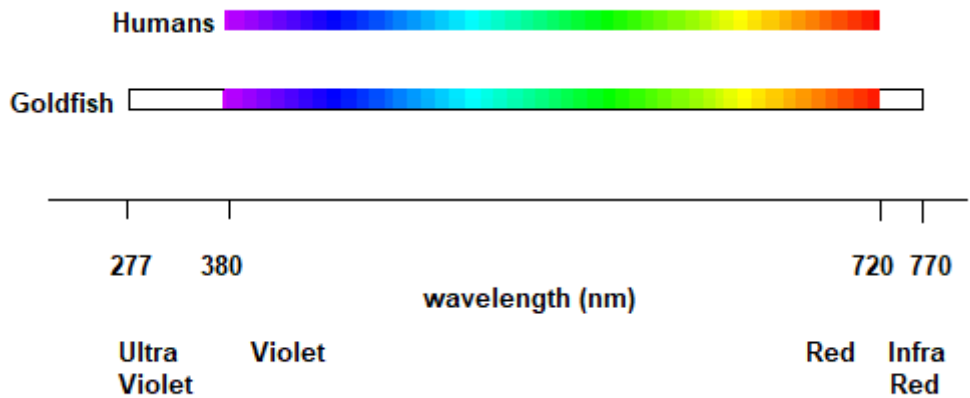

Suggest why vision works within this range of light wavelengths for so many organisms.

.....

.....

**End of questions for the 2022 Kilbaha VCE Physics Trial Examination**

<b>Kilbaha Education</b> PO Box 2227 Kew Vic 3101 Australia	<b>Tel: (03) 9018 5376</b> <a href="mailto:kilbaha@gmail.com">kilbaha@gmail.com</a> <a href="https://kilbaha.com.au">https://kilbaha.com.au</a>
--	---

## Formula List

### Motion and related energy transformations

velocity, acceleration	$v = \frac{\Delta x}{\Delta t}$ $a = \frac{\Delta v}{\Delta t}$
equations for constant acceleration	$v = u + at$ $s = ut + \frac{1}{2}at^2$ $s = vt - \frac{1}{2}at^2$ $v^2 = u^2 + 2ax$ $x = \frac{1}{2}(v + u)t$
Newton's second law	$\Sigma F = ma$
circular motion	$a = \frac{v^2}{r} = \frac{4\pi^2 r}{T^2}$
Hooke's law	$F = -k\Delta x$
elastic potential energy	$\frac{1}{2}k\Delta x^2$
gravitational potential energy near the surface of the Earth	$mg\Delta h$
kinetic energy	$\frac{1}{2}mv^2$
Newton's law of universal gravitation	$F = G\frac{M_1M_2}{r^2}$
gravitational field	$g = G\frac{M}{r^2}$
impulse	$F\Delta t$
momentum	$mv$
Lorentz factor	$\gamma = \frac{1}{\sqrt{1 - \frac{v^2}{c^2}}}$
time dilation	$t = t_o \gamma$
length contraction	$L = \frac{L_o}{\gamma}$
rest energy	$E_{rest} = E_o = mc^2$
relativistic total energy	$E_{total} = \gamma mc^2$
relativistic kinetic energy	$E_K = (\gamma - 1)mc^2$



### Fields and application of field concepts

electric field between charged plates	$E = \frac{V}{d}$
energy transformations of charges in an electric field	$\frac{1}{2}mv^2 = qV$
field of a point charge	$E = \frac{kq}{r^2}$
force on an electric charge	$F = qE$
Coulomb's law	$F = \frac{kq_1q_2}{r^2}$
magnetic force on a moving charge	$F = qvB$
magnetic force on a current carrying conductor	$F = nIlB$
radius of a charged particle in a magnetic field	$r = \frac{mv}{qB}$

### Generation and transmission of electric power

voltage, power	$V = RI, P = VI = I^2R$
resistors in series	$R_T = R_1 + R_2$
resistors in parallel	$\frac{1}{R_T} = \frac{1}{R_1} + \frac{1}{R_2}$
ideal transformer action	$\frac{V_1}{V_2} = \frac{N_1}{N_2} = \frac{I_2}{I_1}$
AC voltage and current	$V_{RMS} = \frac{1}{\sqrt{2}}V_{Peak}, I_{RMS} = \frac{1}{\sqrt{2}}I_{Peak}$
electromagnetic induction	$EMF: \varepsilon = -N\frac{\Delta\Phi_B}{\Delta t}, Flux: \Phi = B_{\perp}A$
transmission losses	$V_{Drop} = I_{Line}R_{Line}, P_{Loss} = I_{Line}^2R_{Line}$

### Wave concepts

wave equation	$v = f\lambda$
constructive interference	$path\ difference = n\lambda$
destructive interference	$path\ difference = (n - \frac{1}{2})\lambda$
fringe spacing	$\Delta x = \frac{\lambda L}{D}$
Snell's Law	$n_1 \sin \theta_1 = n_2 \sin \theta_2$
refractive index and wave speed	$n_1 v_1 = n_2 v_2$

### Nature of light and matter

photoelectric effect	$E_{K \max} = hf - W$
photon energy	$E = hf$
photon momentum	$p = \frac{h}{\lambda}$
de Broglie wavelength	$\lambda = \frac{h}{p}$

### Data

acceleration due to gravity at the Earth's surface	$g = 9.8 \text{ ms}^{-2}$
mass of the electron	$m_e = 9.1 \times 10^{-31} \text{ kg}$
magnitude of charge of the electron	$e = 1.6 \times 10^{-19} \text{ C}$
Planck's constant	$h = 6.63 \times 10^{-34} \text{ J s}$ $h = 4.14 \times 10^{-15} \text{ eV s}$
speed of light in a vacuum	$c = 3.0 \times 10^8 \text{ m s}^{-1}$
universal gravitational constant	$G = 6.67 \times 10^{-11} \text{ N m}^2 \text{ kg}^{-2}$
mass of the Earth	$m_E = 5.98 \times 10^{24} \text{ kg}$
radius of the Earth	$r_E = 6.37 \times 10^6 \text{ m}$
Coulomb constant	$k = 8.99 \times 10^9 \text{ N m}^2 \text{ C}^{-2}$

### Prefixes

p = pico = $10^{-12}$	n = nano = $10^{-9}$	$\mu$ = micro = $10^{-6}$	m = milli = $10^{-3}$
k = kilo = $10^3$	M = mega = $10^6$	G = giga = $10^9$	t = tonne = $10^3 \text{ kg}$

End of formula sheet for the 2022 Kilbaha VCE Physics Trial Examination

<b>Kilbaha Education</b> <b>PO Box 2227</b> <b>Kew Vic 3101</b> <b>Australia</b>	<b>Tel: (03) 9018 5376</b>  <a href="mailto:kilbaha@gmail.com">kilbaha@gmail.com</a> <a href="https://kilbaha.com.au">https://kilbaha.com.au</a>
---	---