

# PHYSICS UNITS 3&4



## 2020 Practice Exam

(including fully-worked answers for every question!)

### ABOUT THIS RESOURCE

Our VCE Physics Practice Exam is written by our experienced textbook authors and VCE teachers.

- The exam consists of questions worth 130 marks, in exactly the same format as the VCE exam.
- The questions have been designed and written to simulate the experience of sitting a VCAA-style exam.
- Included is a full answer section with exemplar answers and checklists to guide students on how to produce a high-scoring answer.
- All questions are tailored to the study design updates for 2020.

Share this free exam with Physics students to help them prepare for the 2020 exam period!



### EDROLO TEXTBOOKS

The questions and answers in this practice exam have been rigorously designed to help your students understand exactly how to succeed in their upcoming exam, and are modelled on the questions and answers in the new range of Edrolo textbooks, already used and loved by thousands of Victorian students and teachers. Each Edrolo textbook has hundreds of scaffolded exam-style questions, each with full exemplar responses (like you'll find in these pages), plus online video solutions and checklists, all explaining how to get full marks.

Talk to your Edrolo representative about accessing these textbooks today or email [textbooks@edrolo.com](mailto:textbooks@edrolo.com) today.

Learn more about our textbooks: [edrolo.com.au/vic/catalogue/](http://edrolo.com.au/vic/catalogue/)



Want more free Edrolo Practice Exams for other subjects too?

Download these at [edrolo.com.au/freepracticeexams](http://edrolo.com.au/freepracticeexams) for:



**BUSINESS  
MANAGEMENT**



**CHEMISTRY**



**BIOLOGY**



**LEGAL STUDIES**

DATE: \_\_\_\_\_

STUDENT NAME: \_\_\_\_\_

TEACHER NAME: \_\_\_\_\_

# PHYSICS

## Practice written examination

Duration: 15 minutes reading time, 2 hrs 30 minutes writing time

### QUESTION BOOK

#### Structure of book

Section	Number of questions	Number of marks
A	20	20
B	21	110
		Total 130

#### Reminders for students:

Avoid rounding your calculations until you provide your final answer.

For all questions worth more than one mark, working must be shown.

Write the formula you intend to use and then write the equation with the correct substituted values.

In general, marks will be awarded for showing correct substitutions.

Remember to provide your answer in the correct units indicated by the answer box.

For worded responses, ensure your answer addresses the question directly.

### SECTION A – Multiple-choice questions

#### Instructions for Section A

Answer **all** questions in pencil on the answer sheet provided for multiple-choice questions.

Choose the response that is **correct** or that **best answers** the question.

A correct answer scores 1; an incorrect answer scores 0.

Marks will **not** be deducted for incorrect answers.

No marks will be given if more than one answer is completed for any question.

Unless otherwise indicated, the diagrams in this book are **not** drawn to scale.

Take the value of  $g$  to be  $9.8 \text{ m s}^{-2}$ .

#### Question 1

Two identical magnets are arranged perpendicular to each other as shown.

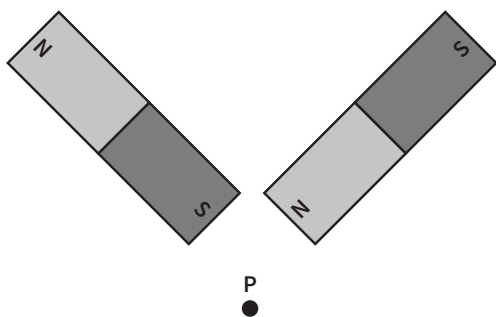

Which one of the following arrows best represents the direction of the resultant magnetic field at point P?

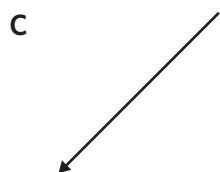

**Question 2**

Stevie and Achol measure the wavelength of a particular signal from a loudspeaker on separate occasions.

Stevie takes the following readings: 2.30 m, 3.10 m, 2.60 m, and 2.90 m (average 2.73 m).

Achol takes the following readings: 1.50 m, 2.70 m, 2.50 m, and 3.90 m (average 2.65 m).

The true value of the wavelength is 2.60 m.

Which one of the following statements best describes these sets of measurements?

- A Both sets of measurements are equally precise.
- B Stevie's measurements are more accurate than Achol's results.
- C Both sets of measurements are equally accurate.
- D Achol's measurements are less precise than Stevie's results.

**Question 3**

Students are investigating the forces involved in vertical circular motion. Their apparatus consists of a ball with a known mass attached to a string that incorporates a sensor for measuring the tension force in the string, as shown.

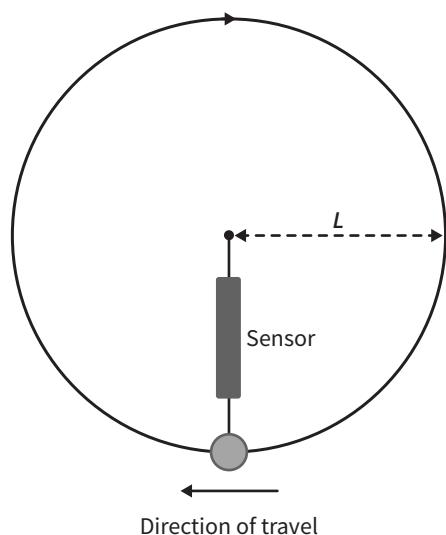

Using the same ball and keeping the period fixed at 0.2 seconds, the students vary the length of the string,  $L$ , and record the maximum tension force when the ball is at the lowest position.

Which one of the following is the best description of the dependent variable in this experiment?

- A The mass of the ball
- B The tension force in the string
- C The length of the string
- D The period of each rotation

**Question 4**

A ball is attached to a string and travelling in a horizontal circle as shown.

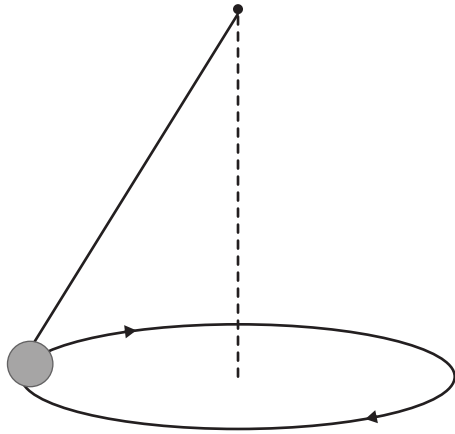

Which one of the following arrows best represents the direction of the resultant force acting on the ball in the position shown?

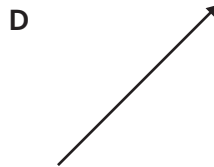
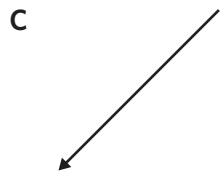
**Question 5**

Which one of the following is the **best** description of light?

- A** An electric wave which is produced by charges
- B** An electromagnetic wave which is produced by a constant current, which in turn produces a magnetic field
- C** An electromagnetic wave which is produced by accelerating charges, which in turn produces changing electric fields and changing magnetic fields
- D** A discrete electron which has been ejected from a material with an energy proportional to its frequency

**Question 6**

A particle travels 20 metres in a straight line in a science laboratory. The particle's rest energy is one-quarter of its kinetic energy.

The distance travelled by the particle as measured in its reference frame is closest to

- A** 4.0 metres.
- B** 5.0 metres.
- C** 20 metres.
- D** 80 metres.

**Question 7**

An unstable subatomic particle at rest decays completely into electromagnetic radiation. The mass of the particle is  $3.2 \times 10^{-27}$  kg.

The energy released in this decay is closest to

- A  $2.1 \times 10^{-35}$  J.
- B  $9.6 \times 10^{-19}$  J.
- C  $2.9 \times 10^{-10}$  J.
- D  $2.8 \times 10^{-43}$  J.

**Question 8**

Which one of the following statements **best** describes the single photon double slit experiment?

- A The experiment provides evidence for the wave nature of light because each photon produces an interference pattern.
- B The experiment provides evidence for the particle nature of light because it demonstrates that photons have momentum.
- C The experiment provides evidence for the dual nature of light because photons interfere with each other and each photon produces one bright band.
- D The experiment provides evidence for the dual nature of light because individual photons produce discrete spots on the screen but, over time, the collection of spots produces an interference pattern.

**Question 9**

The energy levels of the hydrogen atom are shown.

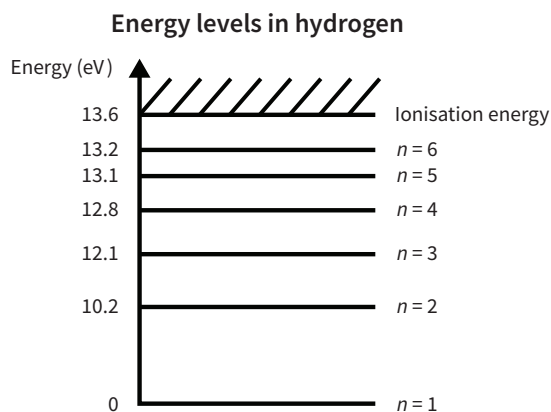

Which one of the following is closest to the longest wavelength photon that can be emitted when an electron transitions to a lower energy level from the  $n = 4$  state?

- A  $1.2 \times 10^{-5}$  m
- B  $1.8 \times 10^{-6}$  m
- C  $9.7 \times 10^{-8}$  m
- D  $2.8 \times 10^{-25}$  m

**Question 10**

Students conducting the photoelectric experiment record the following results for the maximum kinetic energies of photoelectrons at various frequencies.

Max. kinetic energy (eV)

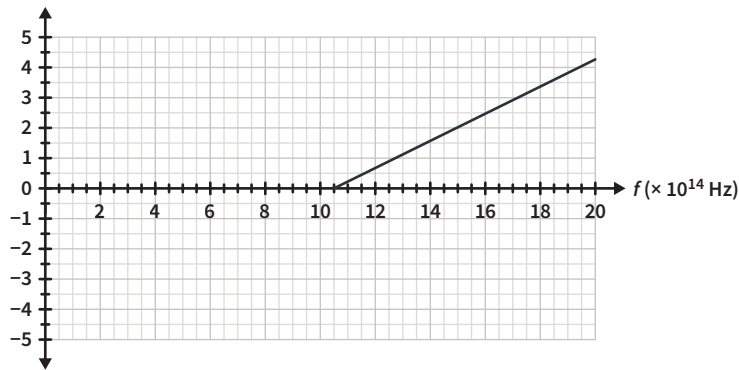

The work function of various metals are shown.

Metal	Work function
selenium	1.90 eV
sodium	2.75 eV
copper	4.70 eV
gold	5.30 eV

Which metal was used in the students' experiment?

- A selenium
- B sodium
- C copper
- D gold

Use the following information to answer Questions 11 and 12.

Equal current is flowing in opposite directions along two parallel wires that are 2.0 cm apart, as shown. The magnitude of the magnetic field strength at each wire due to the other wire is  $3.0 \times 10^{-2}$  T.

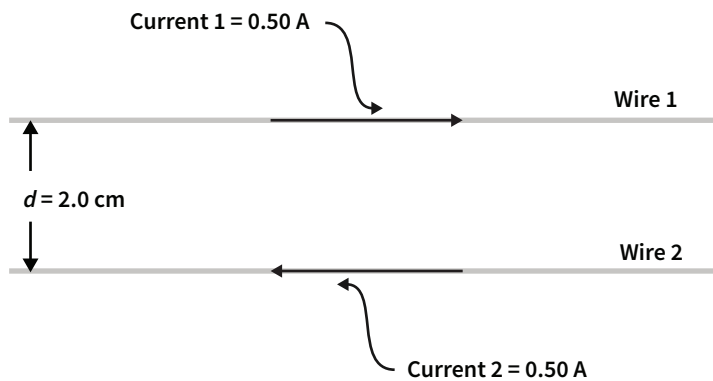

**Question 11**

Which one of the following best describes the direction of the magnetic force **on Wire 1** due to Wire 2?

- A up the page
- B down the page
- C into the page
- D out of the page

**Question 12**

Which one of the following is closest to the magnitude of the magnetic force on each metre of wire?

- A  $6.0 \times 10^{-2}$  N
- B  $3.0 \times 10^{-2}$  N
- C  $1.5 \times 10^{-2}$  N
- D  $3.0 \times 10^{-4}$  N



**Question 13**

The graph shows the variation in magnetic flux versus time for a conducting loop that is rotating inside a uniform magnetic field.

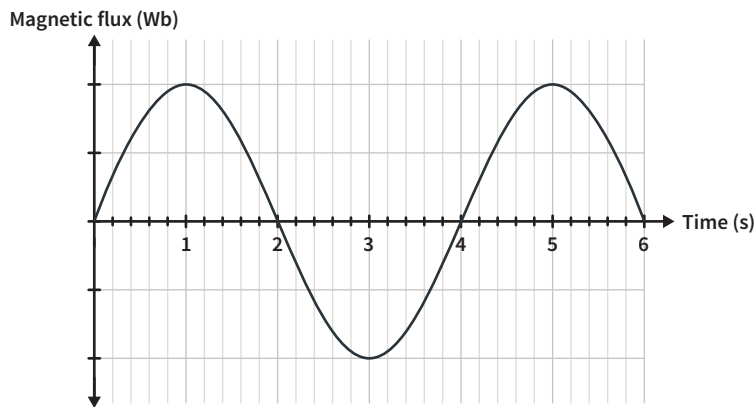

Which one of the following best represents the variation in the induced EMF in the loop during this six-second period?

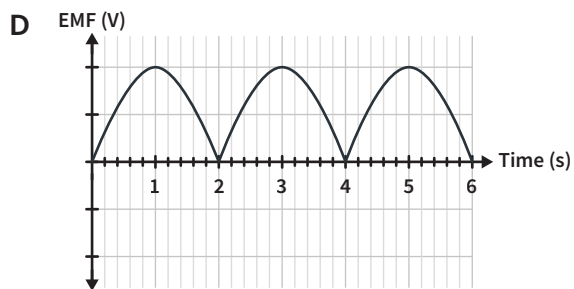
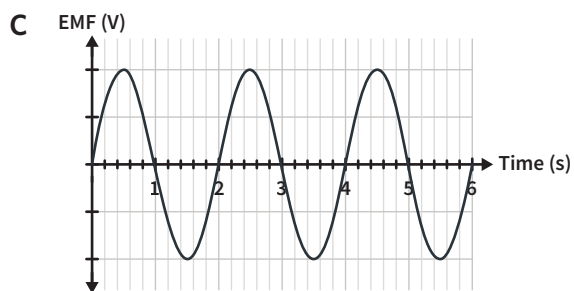
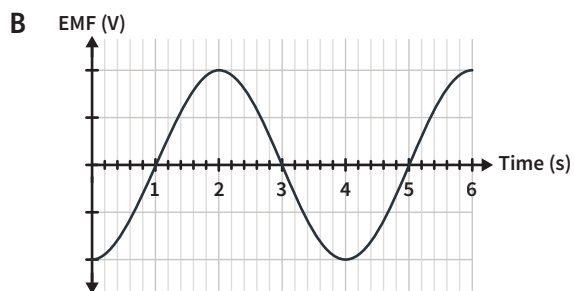
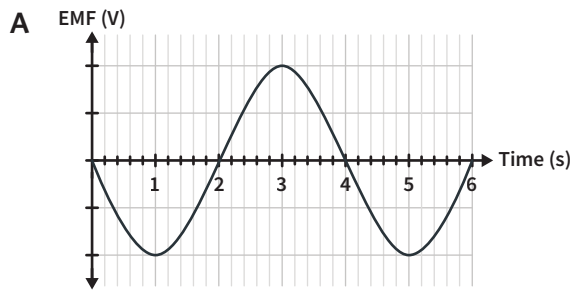

**Question 14**

Which one of the following statements best describes the conclusions we can draw when photons and electrons produce similar diffraction patterns as they pass through the same crystal lattice?

- A They have the same energy, momentum, and wavelength.
- B They have the same energy and momentum but different wavelengths.
- C They have different energies and momenta but the same wavelength.
- D They have different energies but the same momentum and wavelength.

**Question 15**

Two blocks are in contact and they are pushed along a horizontal frictionless surface by an external force with magnitude  $F$  as shown. The mass of Block 1 is  $m$  and the mass of Block 2 is  $2m$ .

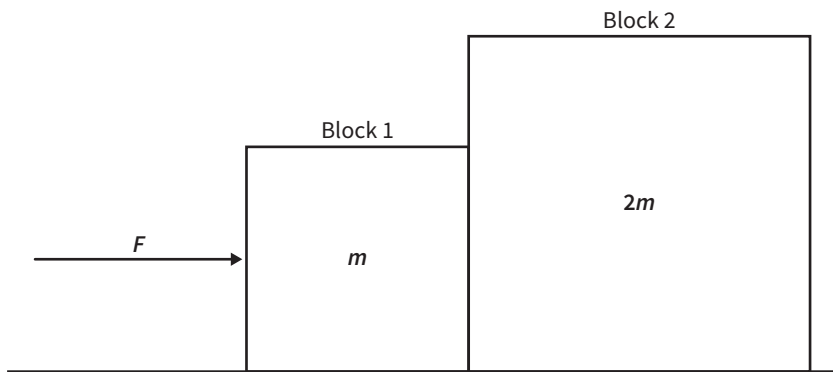

Which one of the following statements is true?

- A The net force on both blocks is the same.
- B The net force on Block 1 only is  $F$ .
- C The net force on Block 1 is  $\frac{F}{2}$ .
- D The net force on Block 1 is  $\frac{F}{3}$ .

**Question 16**

A mass is attached to a hanging spring and then released, as shown.

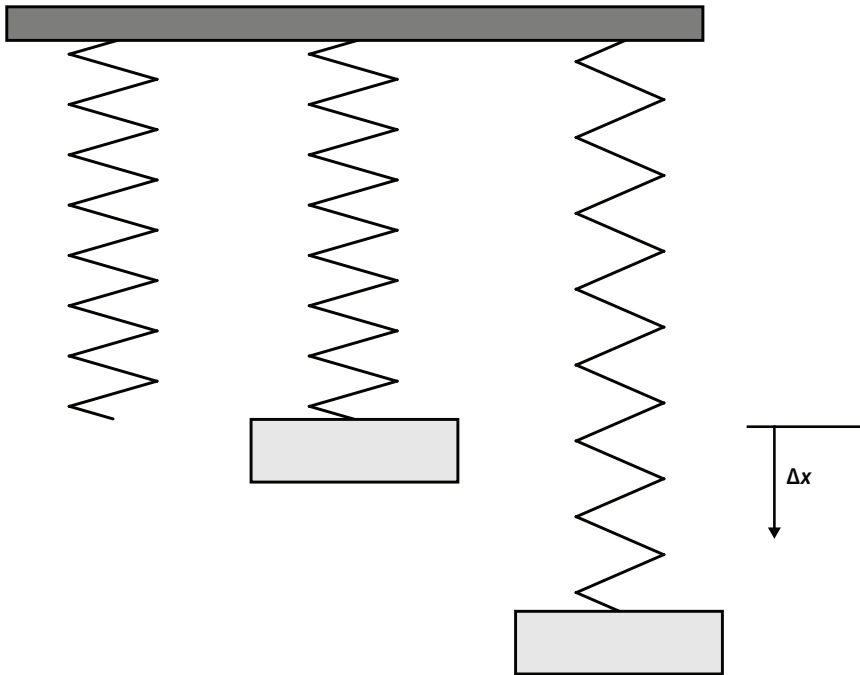

The following graph shows how various types of energy vary for the different positions of the mass.

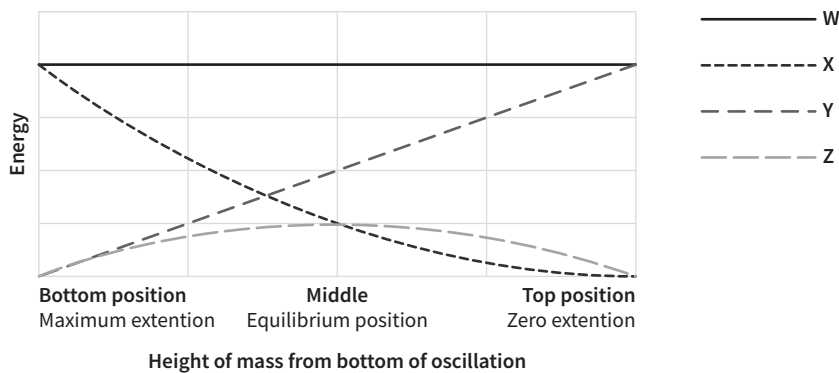

Which of the following could correctly identify the types of energy represented by each curve on the graph?

	Gravitational potential energy	Kinetic energy	Spring potential energy	Total mechanical energy
<b>A</b>	W	X	Y	Z
<b>B</b>	X	Y	Z	W
<b>C</b>	Y	Z	X	W
<b>D</b>	Z	X	Y	W

**Question 17**

A toy car is released from rest so that it rolls down a ramp and then continues along a vertical circular loop as shown. Point P is the top of the circular loop. The diameter of the circular loop is 0.30 m and the car starts from a height  $h$  m. Ignore friction in this question.

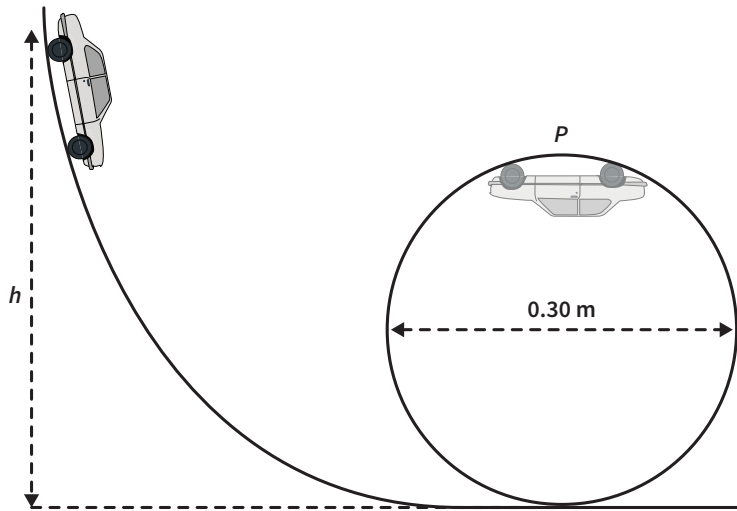

For which one of the following statements can we be certain that the toy car will complete the entire loop?

- A  $h > 0.30$  m
- B At point P, the normal force on the toy car from the track is greater than zero.
- C At point P, the normal force on the toy car from the track is greater than the gravitational force on the toy car.
- D At point P, the kinetic energy of the toy car is greater than its gravitational potential energy.

**Question 18**

The variation in voltage for an alternating current is shown.

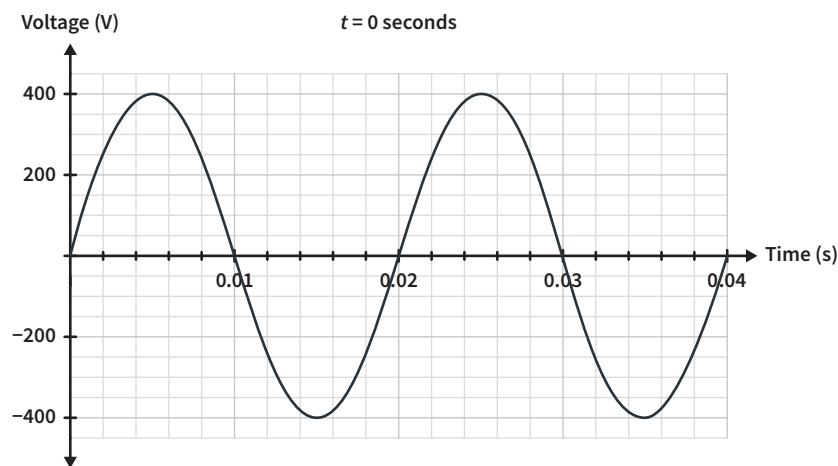

Which one of the following is closest to the value of a DC voltage that would produce the same average power as the varying voltage shown?

- A 200 V
- B 283 V
- C 400 V
- D 566 V

**Question 19**

The graph shows the variation in gravitational field strength versus distance from the centre of the Sun.

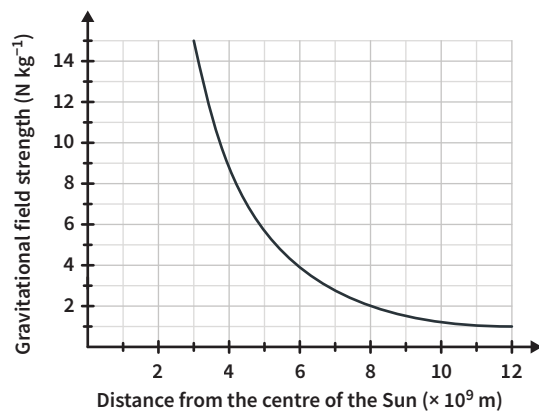

A 200 kg space probe is moving towards the Sun. Assume that the only force acting on the probe is the gravitational force due to the Sun.

Which one of the following is closest to the increase in kinetic energy of the space probe as it moves from a distance of  $10 \times 10^9$  m to a distance  $4 \times 10^9$  m from the centre of the Sun?

- A  $4 \times 10^{12}$  J
- B  $2 \times 10^{10}$  J
- C 4000 J
- D 20 J

**Question 20**

A car that has a mass of 1600 kg drives up a hill at an angle of  $40^\circ$  above the horizontal at a constant speed of  $2 \text{ m s}^{-1}$ .

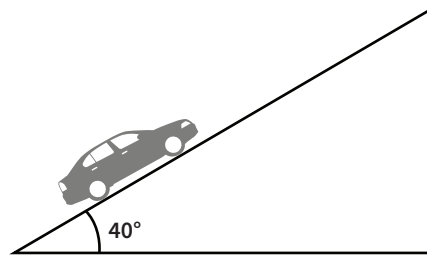

Which one of the following is closest to the magnitude of the friction force on the wheels by the road? Ignore air resistance.

- A  $1.0 \times 10^4$  N
- B  $1.2 \times 10^4$  N
- C  $1.6 \times 10^4$  N
- D  $2.0 \times 10^4$  N

**SECTION B**

**Instructions for Section B**

Answer **all** questions in the spaces provided. Write using blue or black pen.  
 Where an answer box is provided, write your final answer in the box.  
 If an answer box has a unit printed in it, give your answer in that unit.  
 In questions where more than one mark is available, appropriate working **must** be shown.  
 Unless otherwise indicated, the diagrams in this book are **not** drawn to scale.  
 Take the value of  $g$  to be  $9.8 \text{ m s}^{-2}$ .

**Question 1** (8 MARKS)

Figure 1a shows a positive stationary point charge,  $+q_1$ , and three other points (X, Y, and Z) that are evenly spaced apart from each other by a distance  $d$ .

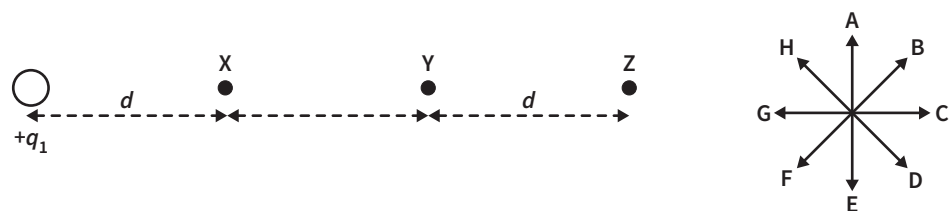

Figure 1a

A **test charge** is placed at point X and it experiences a force of **100 N to the left** (direction G) due to the stationary point charge,  $+q_1$ .

**a** Is the **test charge** positive or negative? Give a reason for your answer. 1 MARK

---



---

**b** Determine the magnitude and direction (A–H) of the force on the **stationary point charge**,  $+q$ . 2 MARKS

---

N	Direction
---	-----------

The test charge is moved from point X to point Y.

c Determine the magnitude of the force on the **test charge** now. Show your working.

2 MARKS

---



---



---

N
---

A second stationary positive charge,  $+q_2$ , that is identical to the first ( $+q_1 = +q_2$ ) is placed at Z, as shown in Figure 1b.

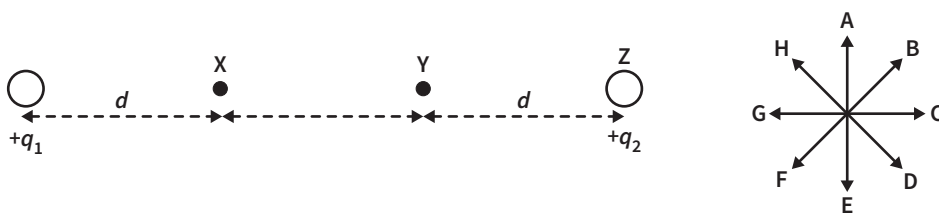

Figure 1b

d Determine the magnitude and direction (A–H) of the resultant force on the **test charge** due to both of the stationary positive charges when it is at point Y.

3 MARKS

---



---



---



---

N
---

Direction
-----------

**Question 2** (6 MARKS)

An electric field accelerates an electron between two plates. The electron exits into a region of uniform magnetic field at right angles to its path, directed into the page, as shown in Figure 2.

**Data**

mass of electron	$9.1 \times 10^{-31} \text{ kg}$
charge on electron	$-1.6 \times 10^{-19} \text{ C}$
accelerating voltage	200 V
distance between plates	50 cm
strength of magnetic field	$5.0 \times 10^{-5} \text{ T}$

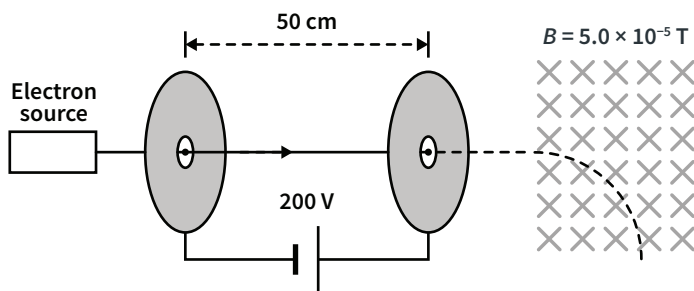

Figure 2

- a** Calculate the magnitude of the force acting on the electron when it is between the two plates. Show your working.

3 MARKS

---



---



---

N

- b** Show that the speed of the electron as it exits the electric field, to two significant figures, is  $8.4 \times 10^6 \text{ m s}^{-1}$ .

1 MARK

---



---



---

- c** Calculate the radius of the path of this electron in the magnetic field. Show your working.

2 MARKS

---



---



---

m



**Question 3** (5 MARKS)

Figure 3 shows a schematic diagram of a DC motor. The motor is initially stationary.

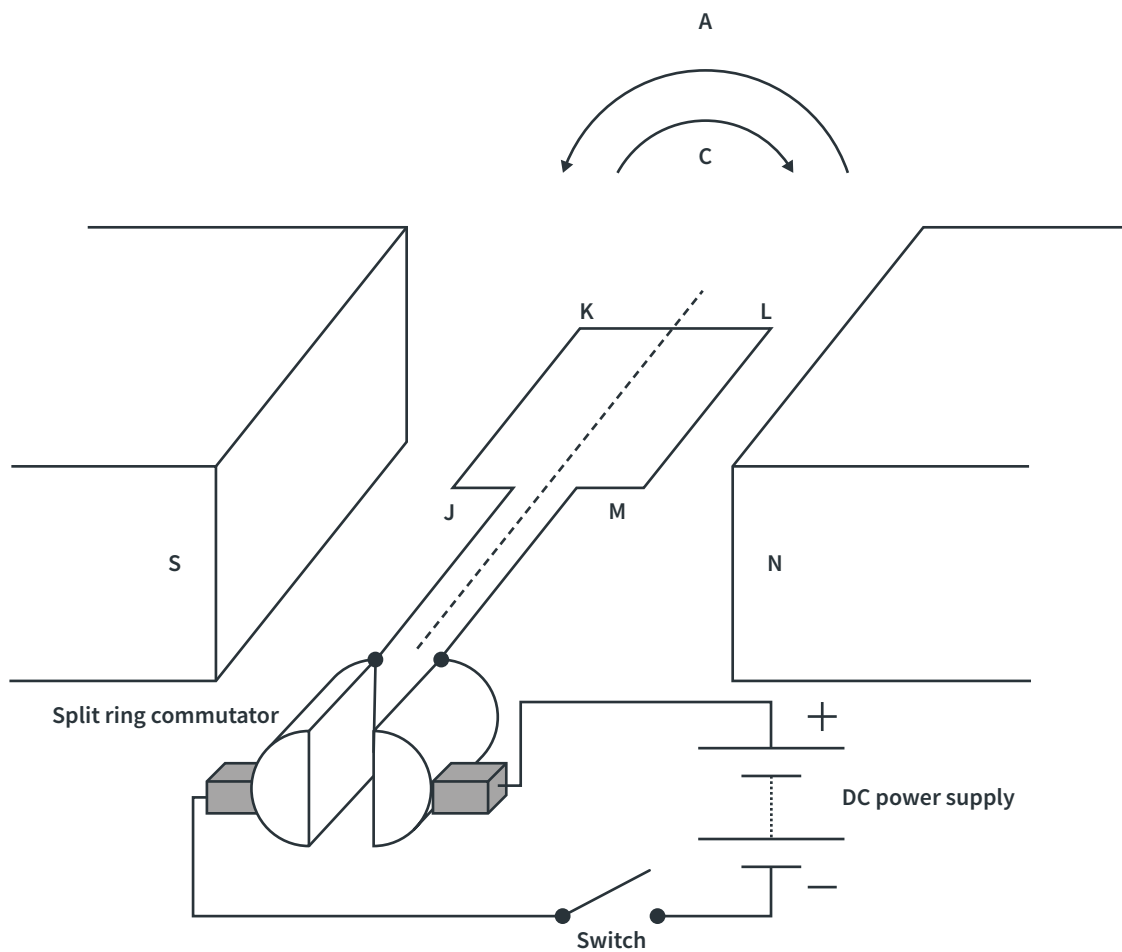

Figure 3

- a** In which direction, A (anticlockwise) or C (clockwise), will the motor rotate when the switch is closed?

1 MARK

Direction

- b** Justify your answer to **part a**.

2 MARKS

---



---



---

- c** Describe what would happen to the operation of the motor if the split ring commutator was replaced with slip rings.

2 MARKS

---



---



---

**Question 4** (6 MARKS)

A 2000 kg artificial satellite is in a circular orbit with a radius of  $7.40 \times 10^6$  m around Earth.

**Data**

mass of satellite	2000 kg
radius of satellite's orbit	$7.40 \times 10^6$ m
mass of Earth	$5.98 \times 10^{24}$ kg
radius of Earth	$6.37 \times 10^6$ m
gravitational constant	$6.67 \times 10^{-11}$ N m <sup>2</sup> kg <sup>-2</sup>

- a** Calculate the gravitational field strength due to the Earth at the position of the satellite. Show your working.

2 MARKS

---



---



---

N kg<sup>-1</sup>

- b** Calculate the orbital speed of the satellite in metres per second. Show your working.

2 MARKS

---



---



---



---

m s<sup>-1</sup>

- c** The satellite is moved into a lower stable orbit to gather new data. Will this increase, decrease, or have no effect on the period of the satellite's orbit? Justify your answer.

2 MARKS

---



---



---



---

**Question 5** (7 MARKS)

Figure 4 shows an alternator consisting of a rectangular coil with sides of  $0.40\text{ m} \times 0.25\text{ m}$ , and 500 turns rotating in a uniform magnetic field. The magnetic flux through the coil in the position shown is  $2.0 \times 10^{-4}\text{ Wb}$ .

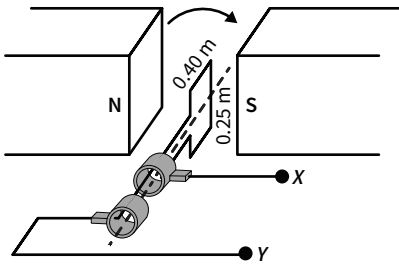

Figure 4

- a Determine the magnitude of the magnetic field between the two magnets. Show your working. 2 MARKS

---



---



---

T

- b The coil rotates a quarter of a revolution in  $8.0\text{ ms}$  from the starting position shown in Figure 4. Calculate the magnitude of the average induced emf in the coil in this time. Show your working. 2 MARKS

---



---



---

V

The speed of rotation is changed. The potential difference between points X and Y for this new speed is shown in Figure 5.

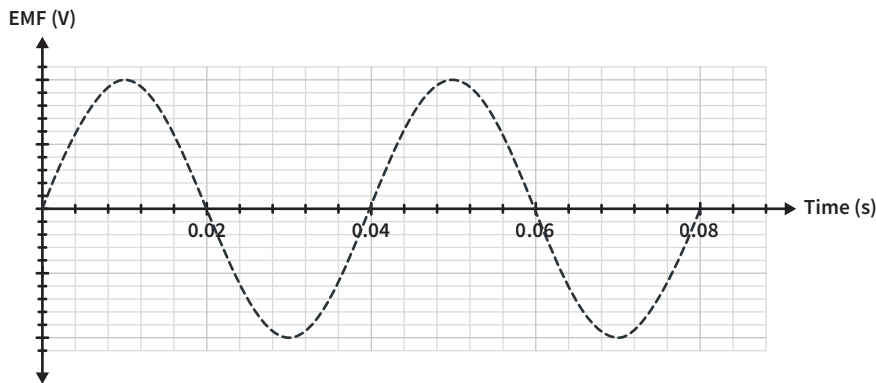

Figure 5

- c On Figure 5, sketch the potential difference between points X and Y if the slip rings were replaced by a split ring commutator **and** the rotation speed was halved.

3 MARKS

**Question 6** (3 MARKS)

Figure 6a shows a square conducting loop that is attached to a pivot so that it swings into and out of the magnetic field produced by a permanent magnet. Figure 6b shows the conducting loop as viewed from the north pole of the magnet, with the loop passing in front of the south pole.

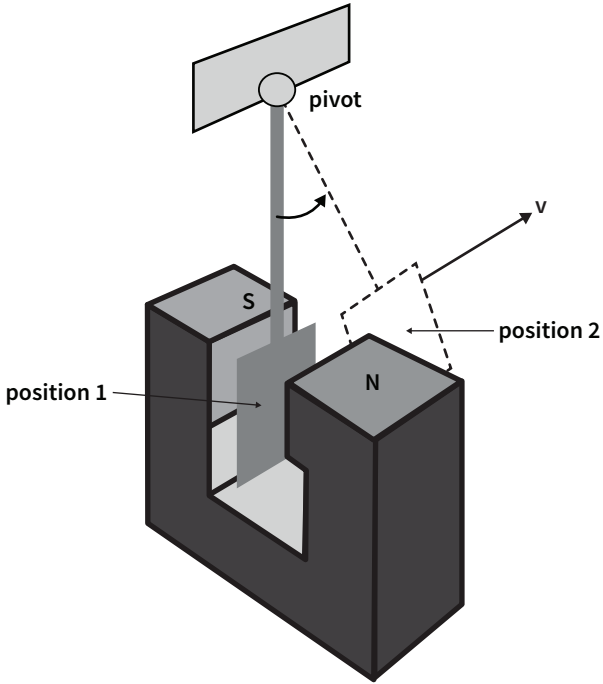

Figure 6a

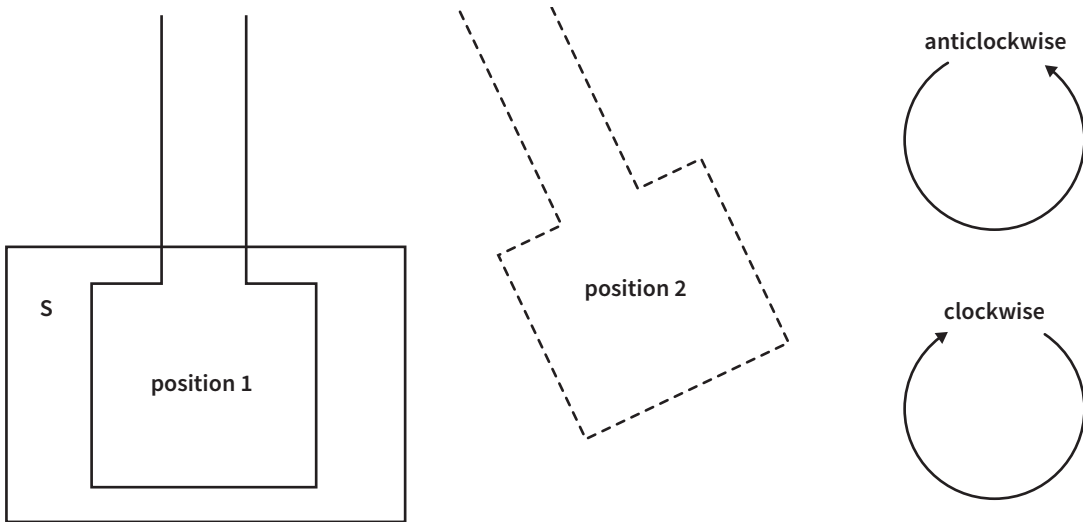

Figure 6b

Determine the direction (clockwise or anticlockwise) of the induced current in the loop as viewed from the north pole of the magnet as it moves from position 1 (inside the field) to position 2 (outside the field). Justify your answer.

---



---



---



---



---

**Question 7** (3 MARKS)

Figure 7 shows two train carriages moving towards each other. Carriage X has a mass of 4.5 tonnes and is travelling at  $5.0 \text{ m s}^{-1}$  to the right. Carriage Y has a mass of 3.5 tonnes and is travelling at a  $7.0 \text{ m s}^{-1}$  to the left. The two carriages lock together when they collide.

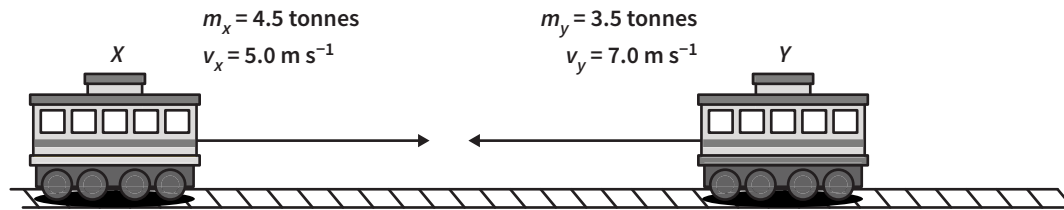

Figure 7

Determine the magnitude and the direction of the velocity of the two carriages after locking together. Ignore friction.

---



---



---



---



---

$\text{m s}^{-1}$
-------------------

Direction
-----------

**Question 8** (5 MARKS)

Figure 8 shows a 200 g toy car that is launched from a compressed spring at point Q along a track. The section of the track at point P is circular with a radius of 0.10 m. The spring can be assumed to be ideal with  $k = 235 \text{ N m}^{-1}$ . Ignore resistance forces.



Figure 8

- a** Show that the minimum speed of the toy car at point P that will make it lose contact with the track is  $0.99 \text{ m s}^{-1}$  to two decimal places. 2 MARKS

---



---



---

- b** Determine the minimum compression of the spring when launching the toy car so that the car leaves the track at point P. Give your answer to the nearest centimetre. Show your working. 3 MARKS

---



---



---



---

cm

**Question 9** (3 MARKS)

Students are conducting an experiment in which a block,  $m_1$ , of mass 0.20 kg is pulled across a smooth surface by a string that is attached over a frictionless pulley to another block,  $m_2$ , of mass 0.30 kg. The second mass is free to fall vertically. This is shown in Figure 9.

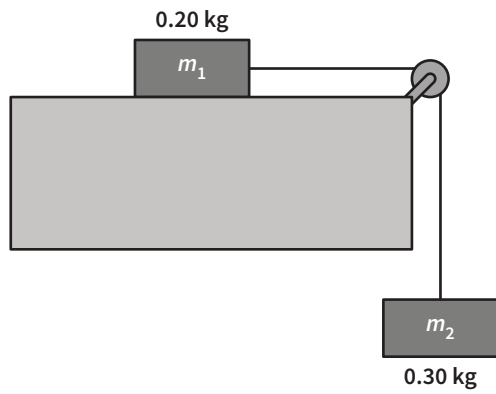

Figure 9

Calculate the magnitude of the tension in the string. Show your working.

---



---



---



---

N
---

**Question 10** (6 MARKS)

A stunt motorbike rider performs a stunt in which she leaves a ramp at an angle of  $60^\circ$  above the horizontal with a speed of  $16 \text{ m s}^{-1}$  and aims to land on top of a wide building that is a horizontal distance of  $10.0 \text{ m}$  from the ramp. The rooftop of the building is  $8.0 \text{ m}$  above the top of the ramp, as shown in Figure 10. Ignore air resistance.

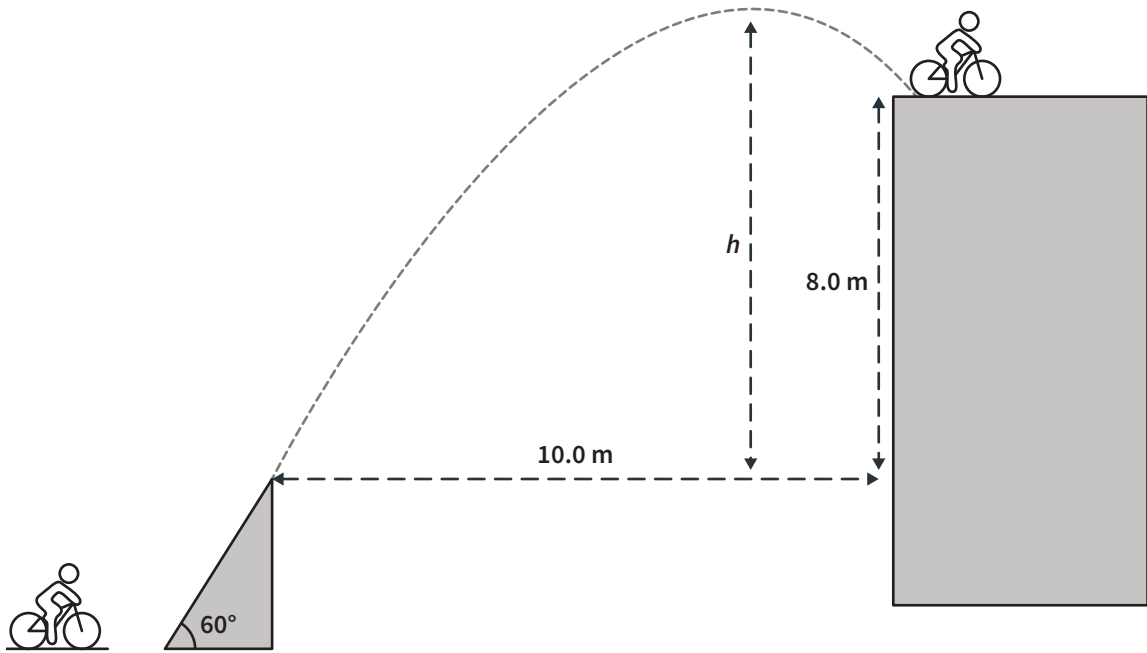

Figure 10

**a** Show that the stunt rider makes it to the rooftop.

3 MARKS

---



---



---



---



---

**b** Calculate the magnitude of the velocity of the motorbike just prior to landing on the rooftop. Show your working.

3 MARKS

---



---



---



---

$\text{m s}^{-1}$
-------------------



**Question 11** (6 MARKS)

Figure 11a shows a steel ball of mass 4.1 kg swinging in a circle at the end of a string of length 0.80 m. The maximum tension that the string can withstand before it breaks is 51 N. Ignore air resistance.

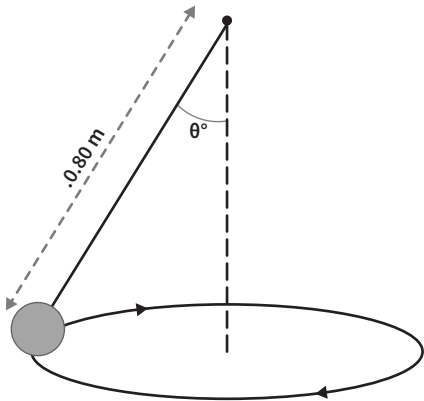

Figure 11a

- a Figure 11b shows the circular path of the ball **when viewed from above**. The string breaks at the moment shown. **On Figure 11b**, draw an arrow to show the direction the ball would travel immediately after the string breaks.

1 MARK

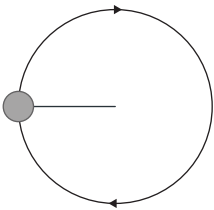

Figure 11b

- b Show that the angle that the string makes **with the vertical** ( $\theta^\circ$  in Figure 11a) when the string is just about to break is  $38^\circ$  (to two significant figures).

2 MARKS

---



---



---



---

- c Calculate the speed of the steel ball when the string is just about to break. Give your answer correct to two significant figures. Show your working.

3 MARKS

---



---



---



---



---

<div style="border: 1px solid black; display: inline-block; padding: 2px 10px;"> <math>\text{m s}^{-1}</math> </div>
--

**Question 12** (3 MARKS)

Students are investigating a spring which is known to have the force-extension relationship shown in Figure 12.

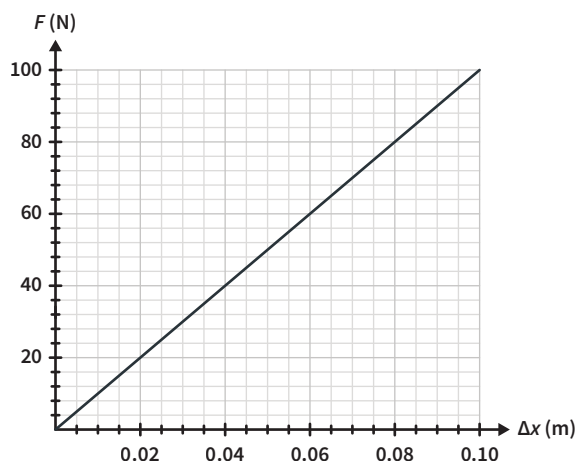

Figure 12

The students aim to verify this relationship. They attach weights of known mass to the spring while it is hanging vertically. They release the weights from the unstretched position and measure the maximum extension of the spring. This setup is shown in Figure 13.

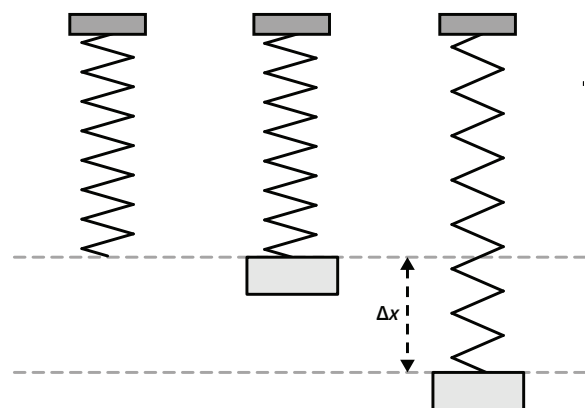

Figure 13

The students obtain the results shown in Table 1.

Table 1

Force due to gravity (N)	Extension (m)
20	0.04
40	0.08
60	0.12

They conclude that the graph in Figure 12 must be wrong because the extension that they have recorded for each weight is double the extension for the same force on the graph.

Explain the mistake the students have made.

---



---



---



---



---

**Question 13** (3 MARKS)

A new particle is discovered travelling at  $0.9682c$ . Take  $\gamma = 4.0$  for this speed. Scientists measure the particle to travel  $6.8 \times 10^{-4}$  m in a straight line before decaying.

Calculate the lifetime of the particle as measured in the particle's frame of reference.

---



---



---



---

s

**Question 14** (4 MARKS)

Students construct a model to show the transmission of electricity in transmission lines. They use a  $5.0 \text{ V}_{\text{RMS}}$  AC power supply and light globe that requires  $4.0 \text{ V}$  across it to operate correctly. They connect the power supply to the globe via transmission lines at two ideal transformers. The current in the transmission lines is measured to be  $0.20 \text{ A}$ . The apparatus is shown in Figure 14.

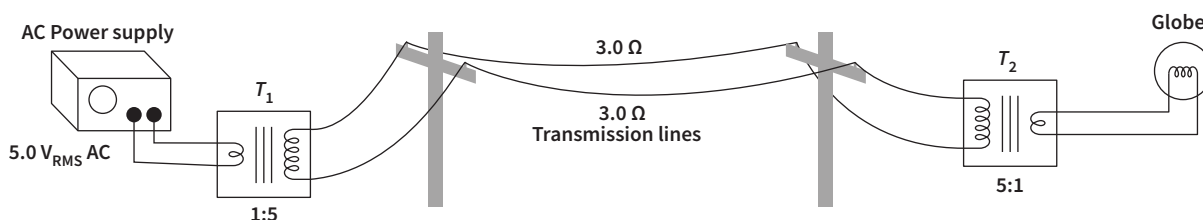

Figure 14

Determine the voltage across the light globe. Show your working.

---



---



---



---

V

**Question 15** (9 MARKS)

Figure 15 shows the displacement-distance graph at  $t = 0$  seconds for a 6-metre length of string which has a transverse wave travelling along it. A point halfway along the string is marked and labelled X. The wave speed on the string is  $8 \text{ m s}^{-1}$ .

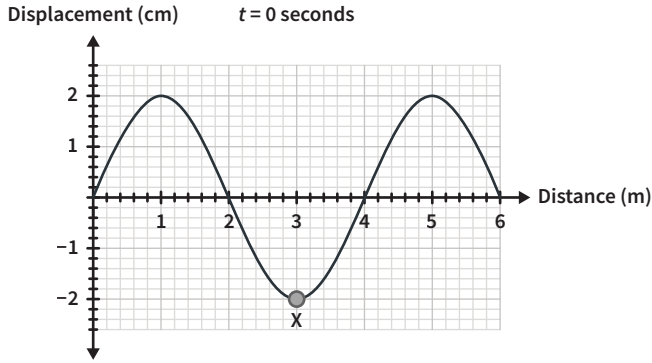

Figure 15

- a Determine the frequency of this wave. Show your working. 2 MARKS

---



---

Hz

- b On the set of axes provided, draw a displacement-time graph for point X between  $t = 0 \text{ s}$  and  $t = 1 \text{ s}$ . 3 MARKS

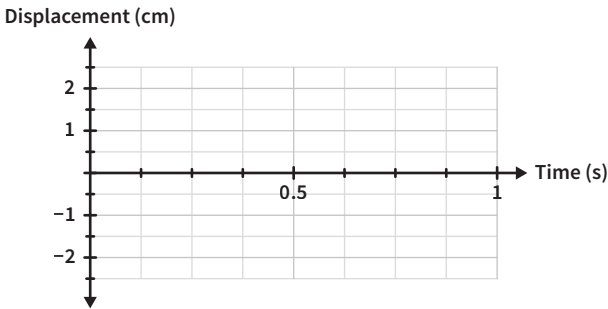

Students fix this string **at one end** to try to make it resonate. Assume that the wave speed is still  $8 \text{ m s}^{-1}$ .

- c Explain how a string can be made to resonate. 2 MARKS

---



---



---

- d Will the travelling wave shown in Figure 15 form a standing wave when the string has **one fixed end**? Give a reason for your answer. 2 MARKS

---



---



---

**Question 16** (11 MARKS)

Students are investigating the interference of sound from two loudspeakers that are producing the same frequency in phase. The two loudspeakers are separated by a fixed distance of 2.0 metres.

The students use a sound level meter to identify regions of maximum sound intensity (loud regions) and regions of minimum sound intensity (quiet regions). They measure the spacing,  $\Delta x$ , between adjacent maxima at various perpendicular distances,  $L$ , from the two speakers.

Take the speed of sound in air to be  $340 \text{ m s}^{-1}$ .

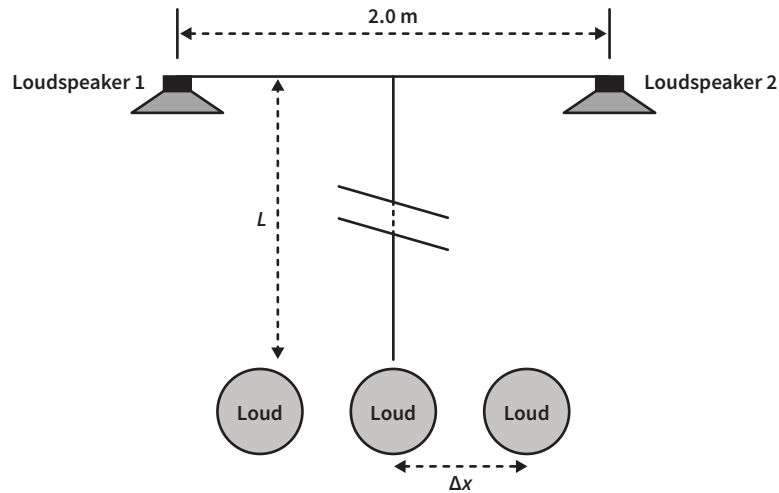

Figure 16

- a** Identify the independent variable, the dependent variable and a controlled variable involved in this experiment. 3 MARKS

Independent variable \_\_\_\_\_

Dependent variable \_\_\_\_\_

Controlled variable \_\_\_\_\_

**b** The students know the value of  $L$  with great accuracy but they estimate the experimental uncertainty for the measurements between adjacent maxima to be  $\pm 0.5$  metres. The students have recorded the data collected in the table below.

5 MARKS

Perpendicular distance $L$ (m)	Spacing $\Delta x$ (m)
10.0	3.5
15.0	6.2
20.0	8.0
25.0	9.4

The relationship between  $\Delta x$  and  $L$  is given by the formula  $\Delta x = \frac{\lambda L}{d}$ .

On the axes provided below:

- Plot a graph of  $\Delta x$  versus  $L$  using the data in the table
- Include the correct uncertainty bars for the  $\Delta x$  values
- Label each of the axes correctly
- Draw a line of best fit

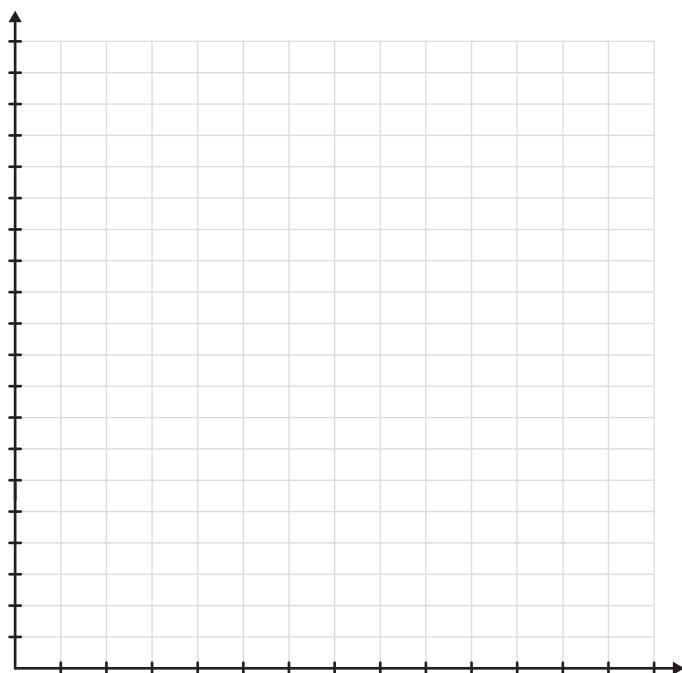

**c** Use the line of best fit to determine the wavelength of the sound produced by the loudspeakers. Show your working.

3 MARKS

---



---



---

m

**Question 17** (3 MARKS)

Students set up a loudspeaker inside a box with a 0.2-metre wide opening, as shown in Figure 17. They use two signals in turn, one of 300 Hz and one of 4000 Hz. The sound intensity level at point P, directly in front of the opening, is the same for both frequencies.

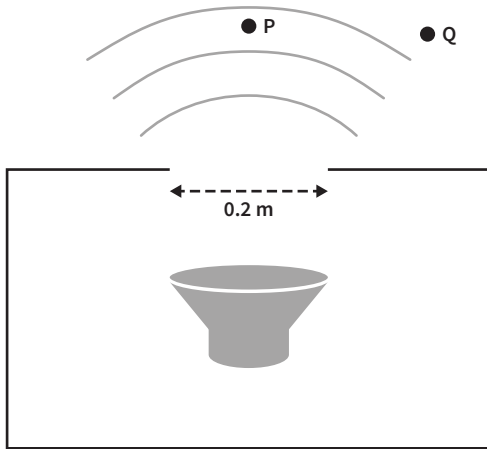

Figure 17

Compare the intensity of the two frequencies when measured at point Q. Justify your answer.

---



---



---



---

**Question 18** (11 MARKS)

Students are studying the photoelectric effect using the apparatus shown in Figure 18.

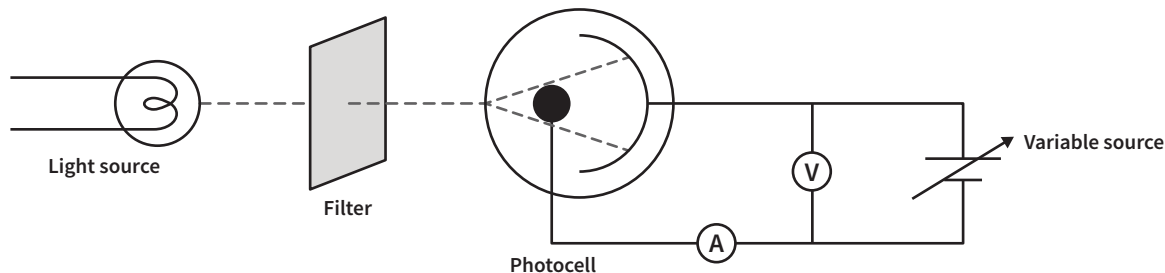

Figure 18

Initially, the students use an unknown metal plate in the apparatus. Figure 19 shows the results the students obtained for the maximum kinetic energy of the emitted photoelectrons versus the frequency of the incoming light.

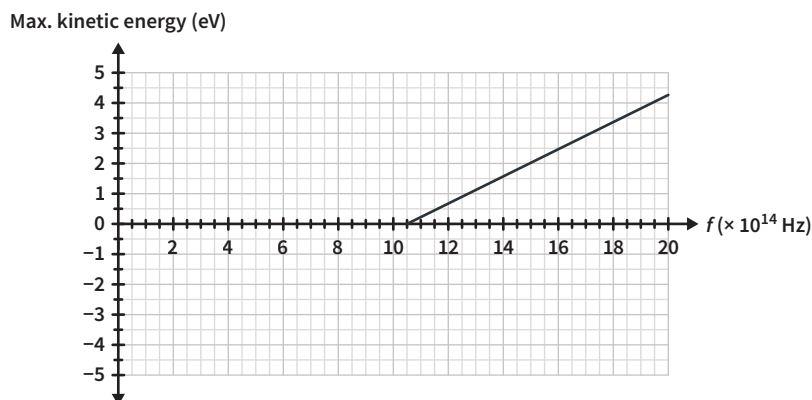

Figure 19

- a** Identify the point on the graph in Figure 19 that the wave model of light fails to predict. Explain why the wave model fails to predict this observation.

3 MARKS

---



---



---



---

- b** Using only the data from Figure 19, determine the value the students would obtain for Planck's constant,  $h$ .

2 MARKS

---



---



---

eV s



The graph of photoelectric current versus potential difference across the photocell for a particular frequency of light shining on the metal is shown in Figure 20.

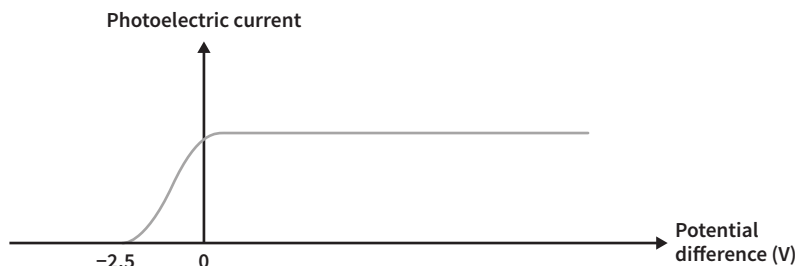

Figure 20

- c Use Figure 20 and Figure 19 to determine the frequency of light that was used when the graph in Figure 20 was produced. 2 MARKS

---



---

Hz
----

- d On the graph of photoelectric current versus potential difference shown in Figure 20, sketch the graph expected if the light is changed to a **higher frequency** with a **lower intensity** than the original light. Specific values are not required. 2 MARKS

- e The metal plate is replaced with a different metal that has a **smaller work function**. The experiment is repeated with this modification.

On the graph of maximum electron kinetic energy versus frequency shown in Figure 19, draw the new graph that the students should expect to obtain. Specific values are not required. 2 MARKS

**Question 19** (3 MARKS)

The apparatus for Young's double slit experiment is shown in Figure 21. The laser produces light of a single wavelength.

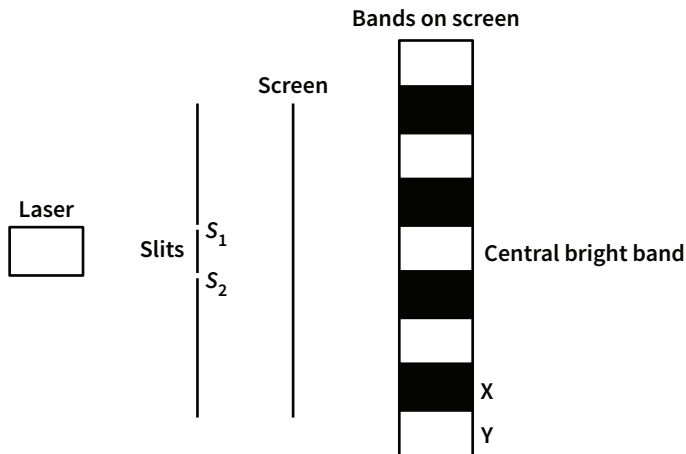

Figure 21 not to scale

The distance from  $S_1$  to the second dark band from the centre, X, is 900 nm further than the distance from  $S_2$  to X.

Calculate the path difference (in metres) from the slits to the second bright band from the centre, Y.

---



---



---



---

m
---

**Question 20** (3 MARKS)

The left-hand side of Figure 22 shows the diffraction pattern produced when electrons with kinetic energies of 500 eV pass through a crystal lattice. The right-hand side of Figure 22 shows a very similar diffraction pattern produced by X-rays as they pass through the same crystal.

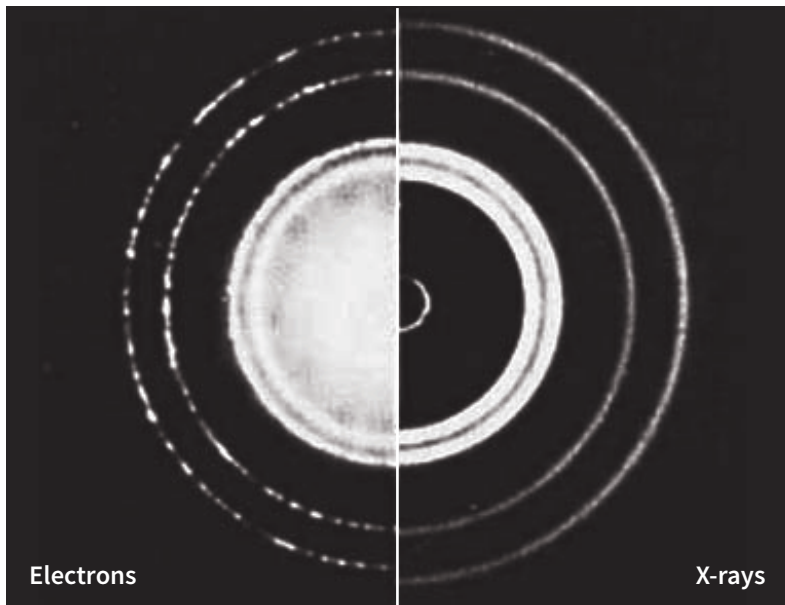

Figure 22

Estimate the energy, in eV, of a photon of these X-rays. Show your working.

---



---



---



---



---

eV
----

**Question 21** (2 MARKS)

Describe how the quantisation of a hydrogen atom's energy levels can be explained by the wave nature of electrons.

---



---



---



---



---

**End of question book**