

## 2019 Trial Examination

STUDENT  
NUMBER

|  |  |  |  |  |  |  |  |  |
|--|--|--|--|--|--|--|--|--|
|  |  |  |  |  |  |  |  |  |
|--|--|--|--|--|--|--|--|--|

Letter

|  |
|--|
|  |
|--|

# PHYSICS

## Unit 2 – Written examination

Reading time: 15 minutes

Writing time: 1 hour and 30 minutes

### QUESTION & ANSWER BOOK

#### Structure of book

| <i>Section</i> | <i>Number of questions</i> | <i>Number of questions to be answered</i> | <i>Number of marks</i> |
|----------------|----------------------------|---|------------------------|
| A              | 15                         | 15  | 15                     |
| B              |                            |   | 55                     |
| C              |                            |   | 20                     |
|                |                            |   | Total 90               |

- Students are permitted to bring into the examination room: pens, pencils, highlighters, erasers, sharpeners and rulers
- Students are NOT permitted to bring into the examination room: blank sheets of paper and/or white out liquid/tape.
- A scientific calculator is permitted in this examination.
- Students are permitted to bring in an A4 page of notes

#### Materials supplied

- Question and answer book of 76 pages.

#### Instructions

- Print your name in the space provided on the top of this page.

**Students are NOT permitted to bring mobile phones and/or any other unauthorised electronic communication devices into the examination room.**

**SECTION A – CORE Multiple-choice questions****Instructions for Section A**

Section A consists of 15 multiple-choice questions. Choose the response that is **correct** or that **best answers** the question. Write the letter corresponding to your chosen answer in the box at the end of each question.

- A correct answer is worth 1 mark, an incorrect answer scores 0.
- Marks will **not** be deducted for incorrect answers.
- No marks will be given if more than one answer is given for any question

**Question 1**

During a recent camping trip, Lachlan walked 10 km east on the first day, 5 km north on the second day and then 4 km east on the last day. His displacement is equal to:

- A. 15 km N 26.57° E
- B. 15 km N 63.43° E
- C. 11.18 km N 26.57° E
- D. 11.18 km N 63.43° E

*The following information refers to Questions 2 and 3*

Figure 1 shows a velocity vs time graph.

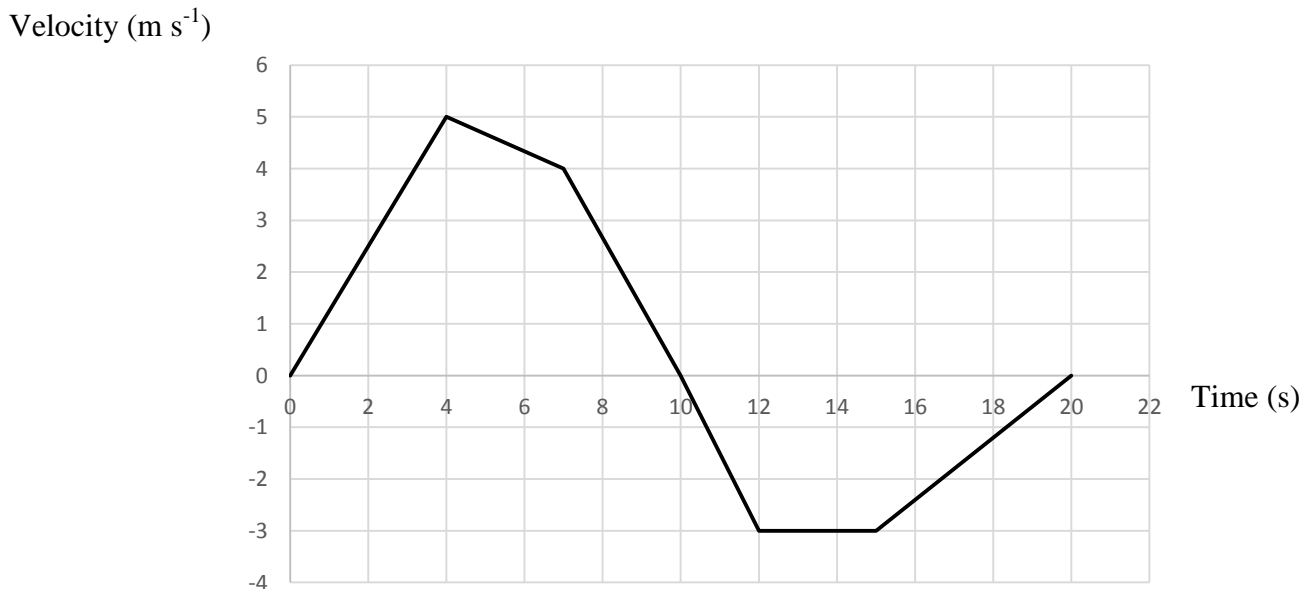

Figure 1

**SECTION A - continued**

**Question 2**

What is the maximum magnitude of the acceleration of this object?

- A.  $1 \text{ m s}^{-2}$
- B.  $1.25 \text{ m s}^{-2}$
- C.  $1.33 \text{ m s}^{-2}$
- D.  $1.5 \text{ m s}^{-2}$

**Question 3**

The magnitude of the displacement of the object at the end of the 20 seconds is equal to

- A. 10 m
- B. 19.5 m
- C. 29.5 m
- D. 49 m

**Question 4**

A ball is thrown vertically upwards with a velocity of  $10 \text{ m s}^{-1}$ . Its velocity 1.5 s later is:

- A.  $10 \text{ m s}^{-1}$  down
- B.  $4.7 \text{ m s}^{-1}$  down
- C.  $10 \text{ m s}^{-1}$  up
- D.  $4.7 \text{ m s}^{-1}$  up

**Question 5**

A car of mass 400 kg travelling at  $60 \text{ km h}^{-1}$  to the right collides head on with a 600 kg car travelling at  $80 \text{ km h}^{-1}$  to the left. If the two cars lock together, their final velocity will be:

- A.  $20 \text{ m s}^{-1}$  right
- B.  $20 \text{ m s}^{-2}$  left
- C.  $48.57 \text{ m s}^{-1}$  right
- D.  $6.65 \text{ m s}^{-1}$  left

**SECTION A – continued**  
**TURN OVER**

**Question 6**

A ball of mass 60 grams hits the floor with a velocity of  $10 \text{ m s}^{-1}$  and rebounds at  $8 \text{ m s}^{-1}$ . If the contact time with the floor was 0.05 s, the force experienced by the ball would be:

- A. 21.6 N up
- B. 2.4 N up
- C. 2400 N up
- D. 21600 N up

**Question 7**

A force of 30 N is applied to the blocks shown in Figure 2.

The blocks are on a frictionless surface. Box A has a mass of 4 kg and Box B has a mass of 2 kg.

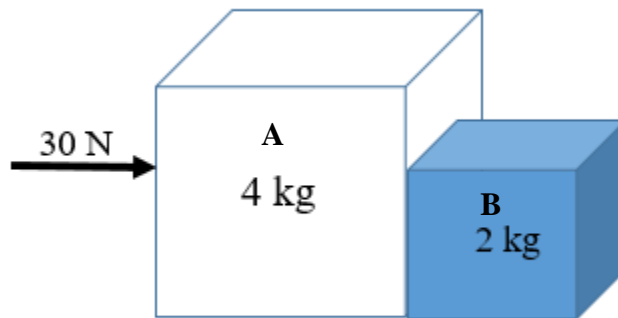

Figure 2

The force of Box B on Box A is equal to:

- A. 30 N
- B. 20 N
- C. 10 N
- D. 5 N

**Question 8**

A box of mass 10 kg is pushed with a force of 5 N and it does not move. The conclusion that can be drawn about this box is:

- A. As the box is too heavy a force of 5 N is not great enough to move it.
- B. Newton's second law does not apply to this situation.
- C. Newton's third law could be used to explain there must be a force of 5 N acting on the block as a reaction force. Hence the block won't move.
- D. There must be at least a 5 N frictional force acting between the block and the floor. Hence the forces are balanced and there is no acceleration.

**Question 9**

A person of mass 50 kg is standing on a set of scales in an elevator which is accelerating. The scales read 60.2 kg. The elevator must be:

- A. Accelerating downwards at  $2 \text{ m s}^{-2}$
- B. Accelerating upwards at  $2 \text{ m s}^{-2}$
- C. Decelerating upwards at  $2 \text{ m s}^{-2}$
- D. Not accelerating; the scales are broken.

**SECTION A – continued  
TURN OVER**

**Question 10**

Max is pulling a wagon with a force of 15 N at an angle of  $30^\circ$  to the horizontal as shown in Figure 3.

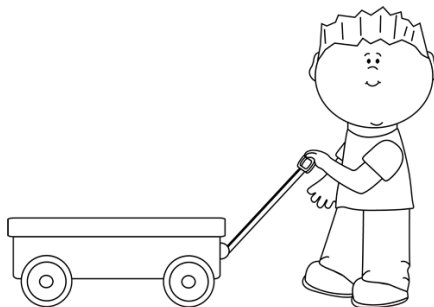

Figure 3

If he pulls it a distance of 20 m, the amount of work done on the wagon is:

- A. 300 J
- B. 259.8 J
- C. 173.21 J
- D. 150 J

*The following information refers to Questions 11 and 12*

A 2 kg mass is attached to a vertically hung spring as shown in Figure 4.

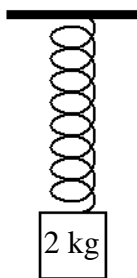

Figure 4

A group of 5 physics students independently measure the length of the stretched spring with a ruler and record values of 24.51, 24.55, 24.50, 24.49, and 24.48 cm.

**SECTION A** - continued

**Question 11**

The result they record as the length of the spring taking into account the error associated with their measurement is:

- A.  $24.51 \pm 0.07$  cm
- B.  $24.5 \pm 0.02$  cm
- C.  $24.5 \pm 0.07$  cm
- D.  $24.51 \pm 0.02$  cm

**Question 12**

The spring constant of the spring is equal to:

- A.  $0.8 \text{ N m}^{-1}$
- B.  $4.80 \text{ N m}^{-1}$
- C.  $8.16 \text{ N m}^{-1}$
- D.  $80 \text{ N m}^{-1}$

**Question 13**

Which of the following could be an example of a dependent variable with its associated independent variable?

- A. The acceleration of a car for a particular mass when force is kept constant
- B. The time taken for a person walking a set distance.
- C. The extension of a spring for a particular weight.
- D. The length of a pendulum for a set period of back and forth motion.

**Question 14**

When examining accuracy and precision in an experiment:

- A. Accuracy describes how close two or more measurements are to each other and precision describes how close the measurements are to theoretical values
- B. Precision describes how close two or more measurements are to each other and accuracy describes how close the measurements are to theoretical values
- C. Precision and accuracy are the same thing and describe how close two or more measurements are to each other.
- D. Precision and accuracy are the same thing and describe how close measurements are to theoretical values.

**SECTION A – continued**  
**TURN OVER**

**Question 15**

A student completes a calculation by multiplying 9.8 by 100 and they are required to write their answer with the correct number of significant figures. They should record their answer as:

- A. 980
- B. 900
- C. 1000
- D.  $9.8 \times 10^2$

**END OF SECTION A**



**SECTION B – CORE Short-answer questions**

**Instructions for Section B**

Section B consists of 8 questions. Answer all questions in the spaces provided.

- Your answers should be expressed correctly using appropriate physics terms.
- Numerical answers should be calculated fully and expressed with the appropriate number of significant figures.
- Where an answer box has a unit printed in it, give your answer in that unit.
- In questions where more than one mark is available, appropriate working should be shown
- Take the value of  $g$  to be  $9.8 \text{ m s}^{-2}$

**Question 1 (4 marks)**

Chris is training for the Tour Down Under bicycle race. In one of his training sessions, he starts from rest at a set of traffic lights and accelerates at a constant rate to a velocity of  $35 \text{ km h}^{-1}$  in 30 seconds.

a. How far did Chris travel during this time?

---

---

m

2 marks

b. What was Chris' acceleration?

---

---

$\text{m s}^{-2}$

2 marks

**SECTION B – continued  
TURN OVER**

**Question 2 (10 marks)**

Figure 1 shows the force versus time graph of tennis racquet on a 58 gram tennis ball during a serve in a recent game of tennis.

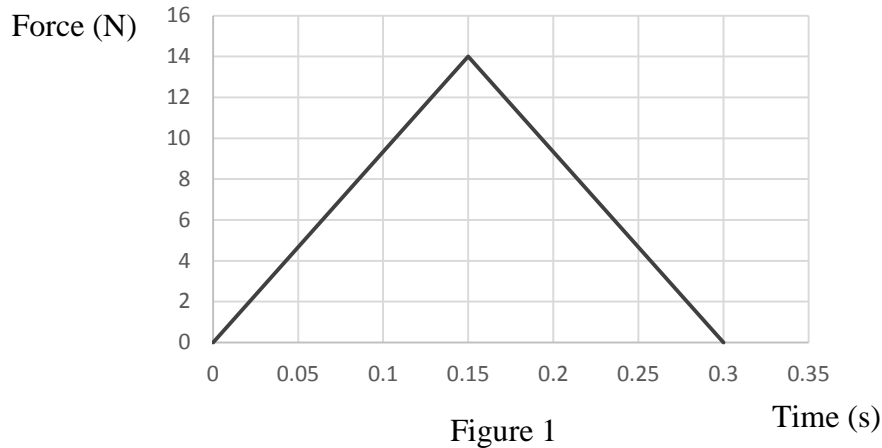

Figure 1

a. What was the impulse applied to the ball?

---

Ns

2 marks

This force produces a horizontal velocity of the ball when it is struck as shown in Figure 2.



Figure 2

**SECTION B** - continued

b. At velocity did the ball leave the racquet?

---

|                   |
|-------------------|
| $\text{m s}^{-1}$ |
|-------------------|

2 marks

The ball then lands down the other end of the court, at a horizontal distance of 24 m away from where it was struck.

c. What was the height of the ball above the ground when it was struck by the player?

---

---

---

---

|   |
|---|
| m |
|---|

3 marks

d. What was the velocity of the ball when it hit the court at the other end?

---

|                   |
|-------------------|
| $\text{m s}^{-1}$ |
|-------------------|

3 marks

**SECTION B – continued**  
**TURN OVER**

**Question 3 (6 marks)**

A child of mass 45 kg stands on a 4 m long diving board of mass 25 kg, which is supported by two vertical pillars as shown in Figure 3. The pillars are 1 m apart.

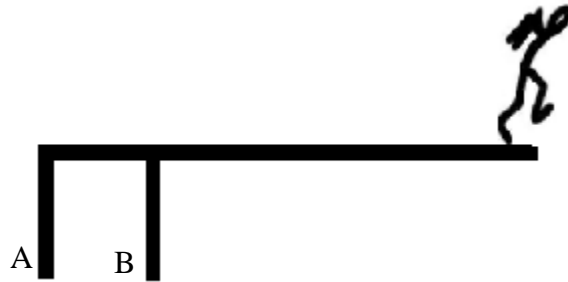

Figure 3

a. What is the magnitude and direction of the force of Pillar A on the board?

---

|   |  |         |
|---|--|---------|
| N |  | 3 marks |
|---|--|---------|

b. What is the magnitude and direction of the force of Pillar B on the board?

---

|   |  |         |
|---|--|---------|
| N |  | 3 marks |
|---|--|---------|

**SECTION B** - continued

**Question 4 (7 marks)**

A block of mass 8 kg is sitting on a  $20^\circ$  inclined plane. There is a 5 kg mass attached via a string and a frictionless pulley as shown in Figure 4. There is also a 10 N frictional force acting between the 8 kg mass and the surface of the incline.

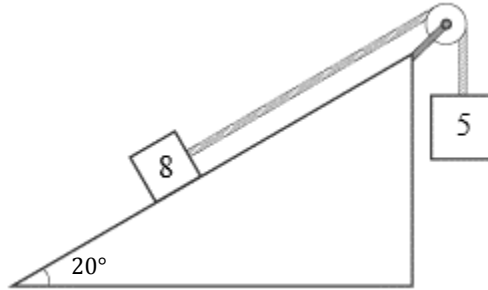

Figure 4

- a. Label the forces in Figure 4 that impact the motion of the blocks.

2 marks

- b. What is the magnitude of the downwards force acting on the 5 kg block?

---



---

2 marks

|   |
|---|
| N |
|---|

- c. If the 5 kg block provides enough force for the system to move, what is the acceleration of the system?

---



---

3 marks

|                   |
|-------------------|
| $\text{m s}^{-2}$ |
|-------------------|

**SECTION B – continued  
TURN OVER**

**Question 5 (4 marks)**

A tractor of mass 2 tonne is pulling a trailer of mass 1.5 tonne as shown in Figure 5. There are frictional forces of 1000 N acting on the tractor and 2500 N acting on the trailer.

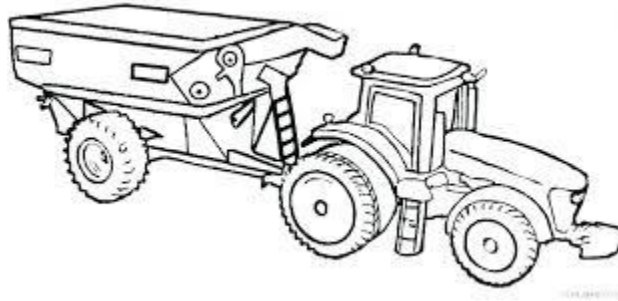

Figure 4

- a. If the tractor and trailer are travelling with **constant velocity**, what is the driving force provided by the tractor?

---

|   |
|---|
| N |
|---|

2 marks

- b. If the tractor now accelerates at  $1.5 \text{ m s}^{-2}$ , what is the tension in the coupling between the tractor and the trailer?

---

|   |
|---|
| N |
|---|

2 marks

**SECTION B** – continued

**Question 6 (7 marks)**

A 1.5 kg medicine ball falls, from rest, onto a spring as shown in Figure 5.

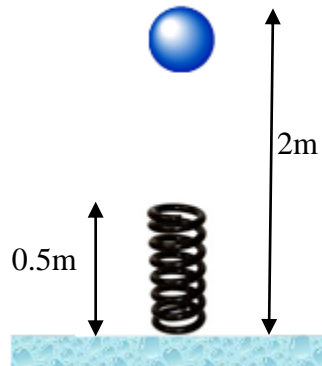

Figure 5

- a.** Calculate the speed of the ball just before it reaches the spring.

---

|                   |         |
|-------------------|---------|
| $\text{m s}^{-1}$ | 2 marks |
|-------------------|---------|

The ball compresses the spring to a height of 0.2 m, at which point it is momentarily stationary.

- b.** Calculate the value of the spring constant,  $k$ .

---

|                   |         |
|-------------------|---------|
| $\text{N m}^{-1}$ | 2 marks |
|-------------------|---------|

**SECTION B – continued  
TURN OVER**

The spring is allowed to recoil sending the ball back up to a height of 1 m above the ground. In this interaction energy is “lost” to other formats

- c. Calculate the amount of energy “lost” during this interaction and explain where the energy has been “lost” to.

---



---



---

J

3 marks

**Question 7 (3 marks)**

Figure 6 shows the collision on two carts in a physics laboratory. Cart A has a mass of 600 grams and is initially travelling at  $2 \text{ m s}^{-1}$ . Cart B has a mass of 750 grams and is travelling at  $1 \text{ m s}^{-1}$ . The two carts collide head on and lock together.



Figure 6

Determine if the collision is elastic or inelastic. Show your working.

---



---

3 marks

**SECTION B – continued**



**Question 8 (14 marks)**

A group of physics students are performing an experiment with the freefall apparatus shown in Figure 7 to measure the acceleration due to gravity of a small metal ball dropped from a series of heights.

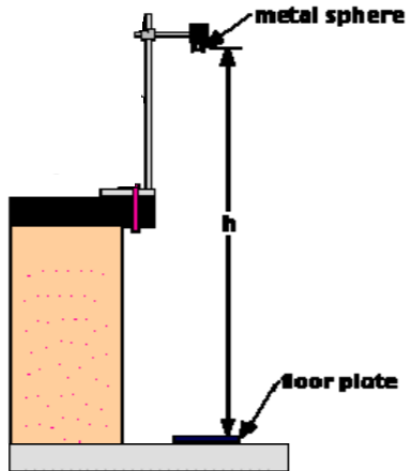

Figure 7

The results they collected are shown in Table 1

| Height (cm) | Time (s) | Height (cm) | Time (s) |
|-------------|----------|-------------|----------|
| 136.5       | 0.528    | 128         | 0.506    |
|             | 0.525    |             | 0.507    |
|             | 0.523    |             | 0.509    |
|             | 0.526    |             | 0.509    |
| 117         | 0.485    | 108.5       | 0.467    |
|             | 0.486    |             | 0.469    |
|             | 0.484    |             | 0.466    |
|             | 0.485    |             | 0.466    |

Table 1

a. Construct a suitable aim for this experiment.

---



---



---

2 marks

**SECTION B – continued  
TURN OVER**

**b.** Identify the independent, dependent and control variables within this experiment

Independent:

---

Dependent:

---

Control:

---

3 marks

**c.** Using your knowledge of constant acceleration, explain the graph that needs to be plotted in order to show a linear relationship between the independent and dependent variables

---

---

---

2 marks

**d.** Construct a graph of this relationship below and find the value of the acceleration.

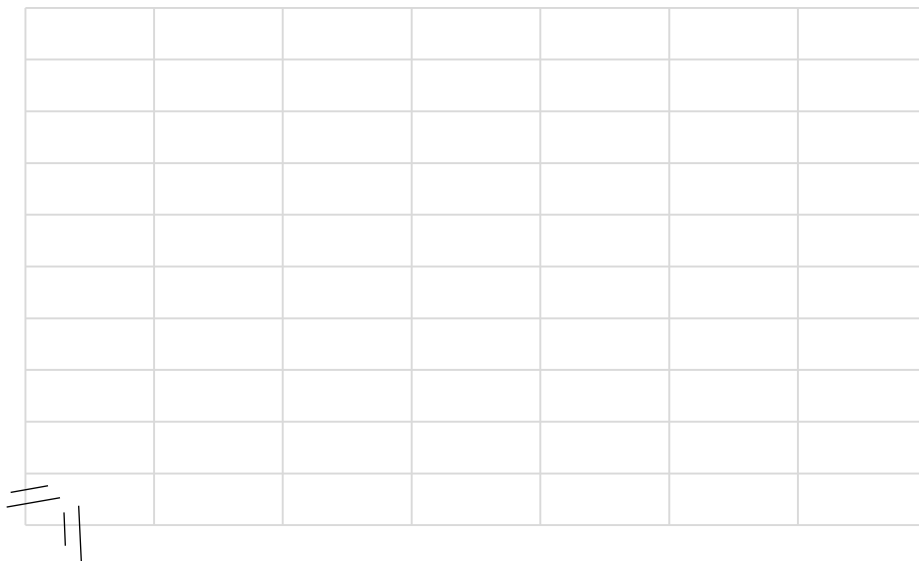

**SECTION B** – continued

---

---

---

---

|                   |
|-------------------|
| $\text{m s}^{-2}$ |
|-------------------|

3 marks

e. State the percentage difference between the theoretical and calculated values.

---

---

|   |
|---|
| % |
|---|

2 marks

f. List two reasons for this error stating if they are systematic or random errors.

---

---

2 marks

**END OF CORE  
TURN OVER**

**SECTION C: Options**

**Instructions for Section C**

Select **ONE** Option and answer **all** questions within that Option.

**Option 2.1: What are stars?**

**Question 1**

Most stars give off energy;

- A. By nuclear fusion of elements heavier than carbon
- B. By the proton cycle or the carbon cycle
- C. Drawing it from a virtual vacuum of a black hole
- D. By burning hydrogen and giving off water

**Question 2**

Analysing the spectra of stars, the hottest stars are;

- A. Red
- B. Orange-yellow
- C. Blue-white
- D. There is no correlation between star colour and temperature

**Question 3**

Our Sun has reached a relatively stable period in its life. In terms of the forces acting inside it this means that:

- A. The gravitational force is greater than the radiation pressure; consequently the Sun is shrinking.
- B. The gravitational force and the radiation pressure are approximately equal; consequently the size of the Sun is relatively constant.
- C. The radiation pressure is greater than the gravitational force; consequently the Sun is shrinking.
- D. Our Sun is one of the oldest stars in the Universe.

**SECTION C – continued**

**Question 4**

Astronomers developed the Hertzsprung-Russell diagram to plot what characteristics of stars?

- A. Luminosity versus surface temperature
- B. Apparent magnitude versus surface temperature
- C. Luminosity versus mass
- D. Absolute magnitude versus apparent magnitude

**Question 5**

At the end of its life cycle our Sun will end up as:

- A. Red Giant
- B. Supernova
- C. White Dwarf
- D. Neutron Star

**Question 6 (9 marks)**

Stars are formed from massive clouds of dust and gases in space.

- a. What force pulls the clouds of dust and gas together?

---

---

1 mark

- b. Once formed, a star can have a stable life for billions of years. Describe the two main forces that work in a star during its life.

---

---

---

---

2 marks

**SECTION C – continued**  
**TURN OVER**

2019 PHYSICS EXAM 2

c. At the end of the stable stage of its life a star will change. Describe and explain the changes that could take place for a star:

i. to become a white dwarf;

---

---

2 marks

ii. To become a black hole.

---

---

2 marks

d. Changes that happen inside stars result in new elements being formed. Describe how nuclei are formed and state which nuclei are likely to be formed.

---

---

2 marks

**SECTION C – continued**

**Question 7 (6 marks)**

Figure 1 below shows an H-R diagram

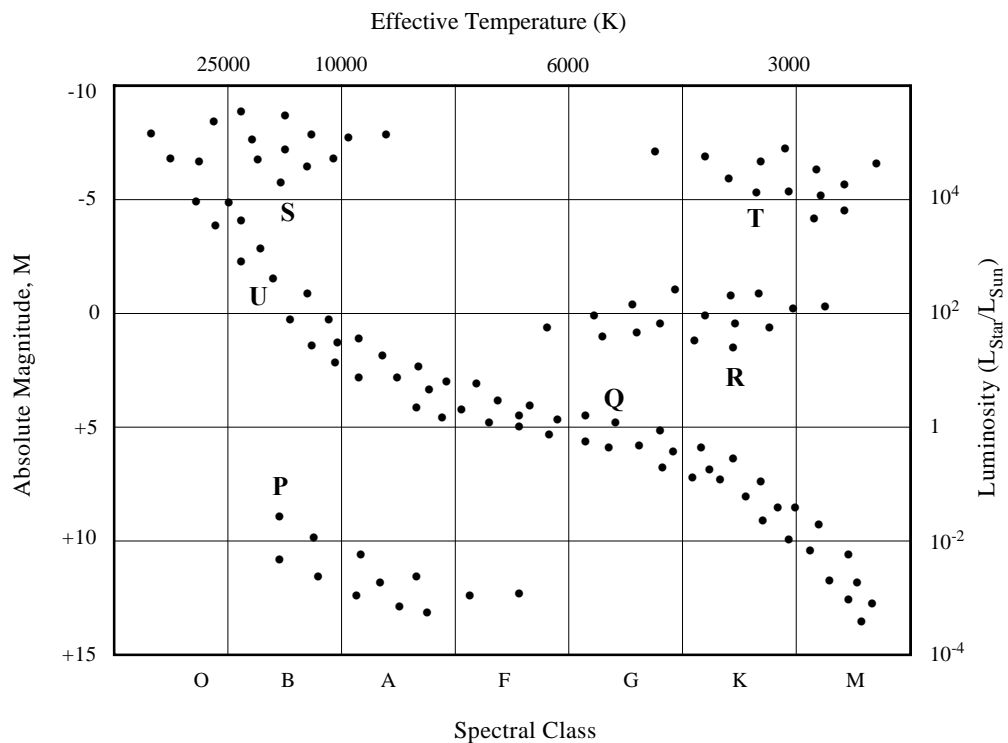

Figure 1

- a. The stars located in the lower right portion of the diagram are cool and dim. What are the characteristics of a star in the upper left portion of the diagram?

---



---

2 marks

- b. What are the characteristics of a star located in the upper right portion of the diagram?

---



---

2 marks

**SECTION C – continued  
TURN OVER**

- c. Betelgeuse is 150 parsecs (480 light years) away and has a surface temperature of only 3200 K (3473°Celsius). Yet Betelgeuse is one of the brightest stars as seen from Earth. Why do you think it is so bright?

---

---

2 marks

**END OF EXAMINATION**



**SECTION C: Options**

**Instructions for Section C**

Select **ONE** Option and answer **all** questions within that Option.

**Option 2.2: If there life beyond the solar system?**

**Question 1**

What defines the *habitable zone* around a star?

- A. The region around a star where rocky planets form
- B. The region around a star where humans can survive
- C. The region around a star where liquid water can potentially exist on planetary surfaces
- D. The region around a star where life exists

**Question 2**

The spectra of most galaxies show redshifts. This means that their spectral lines

- A. Always are in the red part of the visible spectrum
- B. Have wavelengths that are longer than normal
- C. Have wavelengths that are shorter than normal
- D. Have a higher intensity in the red part of the spectrum

**Question 3**

Hubble's Law enables astronomers to estimate the distance to a galaxy if they can determine the galaxies:

- A. Velocity of recession
- B. Mass
- C. Spectral velocity
- D. Temperature

**Question 4**

A spectroscopic binary shows periodic variations in its

- A. Brightness
- B. Spectral lines
- C. Mass
- D. Radial velocity

**SECTION C – continued**

**Question 5**

At present, what is the primary way that the search for extraterrestrial intelligence (SETI) is carried out?

- A. By searching for planets around distant stars.
- B. By using large X-ray telescopes to search for signals from extra-terrestrial civilizations.
- C. By using radio telescopes to search for signals from extra-terrestrial civilizations.
- D. By analysing high-resolution images of nearby stars in the search of evidence of structures that could not have developed naturally.

**Question 6 (10 marks)**

In the early part of the 20<sup>th</sup> century, Edwin Hubble and other astronomers made the first measurements of the spectra from distant stars.

Figure 1 shows an example of an absorption spectrum

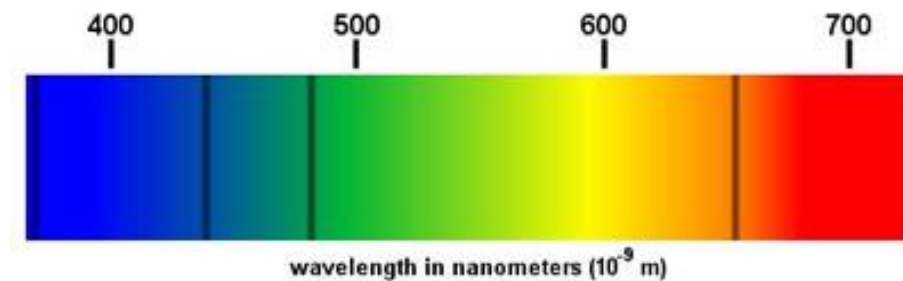

Figure 1

- a. What are the main principles behind the production of such a spectrum?

---

---

2 marks

- b. Surface temperature and rotational velocity are another two factors that can be determined from the spectrum of a star. For each factor, identify the feature of the spectrum that allows the factor to be determined.

---

---

2 marks

**SECTION C – continued**

- c. These astronomers observed the colours emitted from an excited hydrogen atom on Earth and compare it to the spectrum of the same wavelength of the light from the star Vega. The hydrogen on Earth has a wavelength of 656.285 nm and on Vega the same wavelength is 656.255 nm and they used the Doppler Effect to explain this shift. What causes a shift in the spectrum of Vega?

---

---

2 marks

- d. Is Vega moving towards or away from the Earth? Why?

---

---

2 marks

- e. What is the magnitude of the radial velocity of the star?

---

---

2 marks

|                   |
|-------------------|
| $\text{m s}^{-1}$ |
|-------------------|

**SECTION C – continued**  
**TURN OVER**

**Question 7 (5 marks)**

The question of whether there are planets outside our Solar System has intrigued scientists for years.

**a.** Why is it so difficult to detect other planetary systems?

---

---

2 marks

**b.** Describe the two methods used to detect other planetary systems

---

---

---

---

3 marks

**END OF EXAMINATION**

**SECTION C: Options**

**Instructions for Section C**

Select **ONE** Option and answer **all** questions within that Option.

**Option 2.3: How do forces act on the human body?**

**Question 1**

Which has the greatest breaking strength?

- A. Muscle
- B. Cartilage
- C. Tendon
- D. Bone

**Question 2**

What will happen to the centre of mass of a human body if the arms are raised overhead?

- A. It will move up
- B. It will move down
- C. It won't change
- D. More information is required to determine what occurs.

**Question 3**

A runner has an Achilles tendon that measures 162mm long when at rest. As he runs it stretches to 169.5mm. The strain in the tendon is:

- A. 95.5 %
- B. 4.4 %
- C. 4.6 %
- D. 0.046 %

**SECTION C – continued**  
**TURN OVER**

**Question 4**

Which of the following types of levers is least common in the human body?

- A. First class
- B. Second class
- C. Third class
- D. They are all equally as common

**Question 5**

Which of the following is a difficulty when implanting material within the human body?

- A. Immune system resistance.
- B. Individuals need to get used to the implanted material.
- C. It needs to be custom made.
- D. All the above

**Question 6 (6 marks)**

The bones of the forearm (radius and ulna) are hinged to the humerus at the elbow as shown in Figure 1. The biceps muscle connects to the bones of the forearm about 4.5 cm beyond the joint. Assume the forearm has a mass of 1.5 kg.

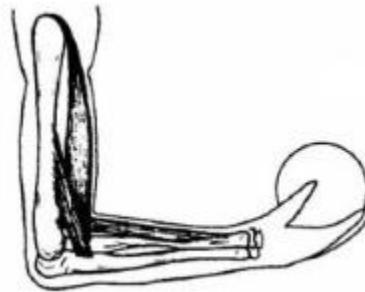

Figure 1

The person in Figure 2 is holding a ball of mass 4.0 kg in such a way that the forearm remains motionless. The centre of mass of the forearm acts at a distance of 20 cm from the elbow and the centre of mass of the ball acts at a distance of 31 cm from the elbow.

**SECTION C – continued**

a. The elbow is an example of one of the three types of levers in the human body. What type of lever is it and how does it act to hold the ball steady?

---

---

---

---

3 marks

b. Calculate the force exerted by the biceps muscle.

---

---

---

---

3 marks

|   |
|---|
| N |
|---|

**SECTION C – continued  
TURN OVER**

**Question 7 (3 marks)**

Figure 2 shows the tensile stress versus strain graph for a human tendon.

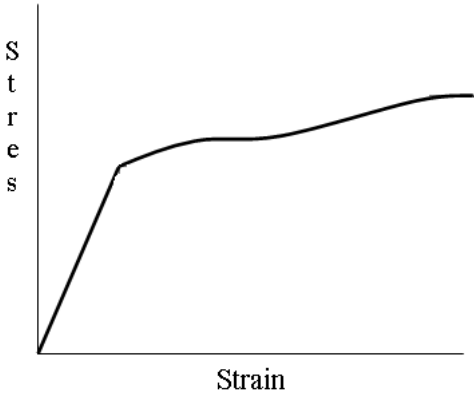

Figure 2

Using the stress versus strain graph as a reference explain what makes a tendon strong and tough

---

---

---

---



**Question 8 (3 marks)**

The total cross-sectional area of the load-bearing calcified portions of the two forearm bones is approximately  $2.5 \text{ cm}^2$ . During a car crash, the forearm is slammed against the dashboard. The arm comes to rest from an initial speed of  $75 \text{ kmh}^{-1}$  in  $4.0 \text{ ms}$ .

If the arm has an effective mass of  $3.0 \text{ kg}$  and bone material can normally withstand a maximum compressional stress of  $6 \times 10^7 \text{ Pa}$ , investigate, with the aid of calculations, whether the arm is likely to withstand the crash?

---

---

---

|  |
|--|
|  |
|--|

3 marks

**Question 9 (3 marks)**

A patient has undergone a knee replacement and the replacement contains a composite material made of carbon fiber and ultra-high molecular weight polyethylene.

What makes the composite material suitable for this use in the human body?

---

---

---

---

**END OF EXAMINATION**

**SECTION C: Options****Instructions for Section C**

Select **ONE** Option and answer **all** questions within that Option.

**Option 2.4: How can AC electricity charge a DC device?**

*The following information relates to Questions 1 and 2.*

A capacitor is charged to 12 V and then discharged through a  $200\ \Omega$  resistor. The voltage across the capacitor as a function of time is shown in Figure 1.

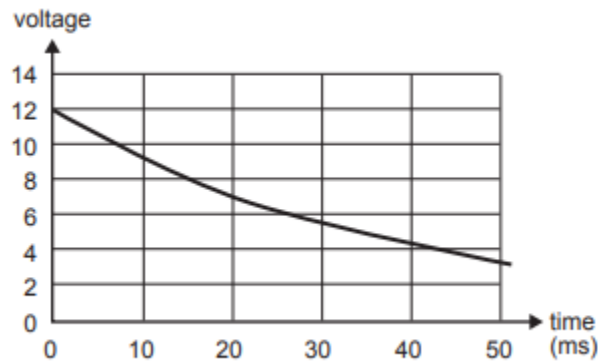

Figure 1

**Question 1**

What is the time constant for this capacitor?

- A. 10 ms
- B. 20 ms
- C. 40 ms
- D. 50 ms

**Question 2**

What is the value of the capacitor?

- A.  $50\ \mu\text{F}$
- B.  $100\ \mu\text{F}$
- C.  $200\ \mu\text{F}$
- D.  $250\ \mu\text{F}$

**SECTION C – continued**

**Question 3**

Which of the following rectifiers requires 4 diodes?

- A. Half-wave voltage divider
- B. Full-wave voltage divider
- C. Full-wave bridge circuit
- D. No of the above

**Question 4**

Within a transformer, increasing the number of turns of wire in the secondary side will;

- A. Increase the primary voltage
- B. Increase the secondary voltage
- C. Decrease the secondary voltage
- D. Have no effect on the secondary voltage

**Question 5**

Light is confined within the core of a simple fibre optic cable by;

- A. Refraction
- B. Total internal reflection at the outer edge of the cladding
- C. Total internal reflection at the core-cladding boundary
- D. Reflection from the fibres plastic coating

**SECTION C – continued**  
**TURN OVER**

**Question 6 (3 marks)**

Figure 1a shows a diode placed in a series circuit with an unknown resistor. When operating correctly the power dissipated in the diode is equal to 300 mW. The V-I characteristics of the diode are shown in Figure 1b

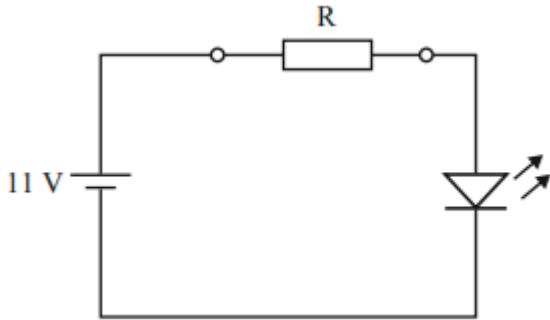

Figure 1a

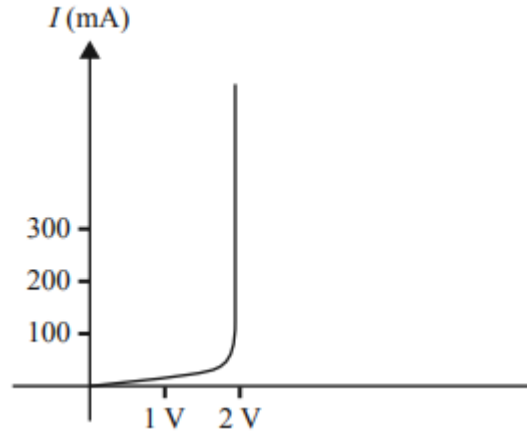

Figure 1b

What is the value of the unknown resistor, labelled R?

---



---



---

|          |
|----------|
| $\Omega$ |
|----------|

3 marks

**SECTION C – continued**

**Question 7 (6 marks)**

Figure 2 shows the application of a diode bridge performing a rectification of the voltage from the output of a transformer. The sinusoidal input voltage of the power supply is  $100V_{RMS}$  and the resistor has a resistance of  $4\text{ k}\Omega$ .

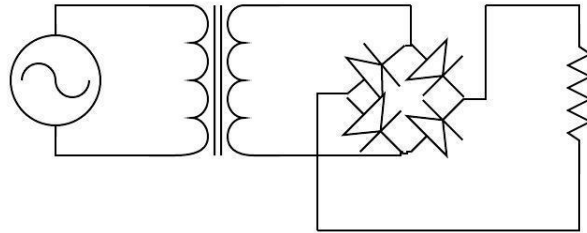

Figure 2

- a. What is the transformer ratio that will give a peak voltage of 8 V on the secondary side of the transformer?

---



2 marks

- b. Assuming the transfer ratio calculated in part a, what is the peak voltage on the output of the full wave bridge rectifier assuming the diodes have a switch on voltage of 0.6 V?

---

 V

2 marks

- c. Calculate the peak current that will flow through any of the four diodes.

---

 mA

2 marks

**SECTION C – continued**

**Question 8 (6 marks)**

Students are constructing a regulated DC power supply, and propose to use a Zener diode as the voltage regulator. The Zener diode characteristic is shown in Figure 3

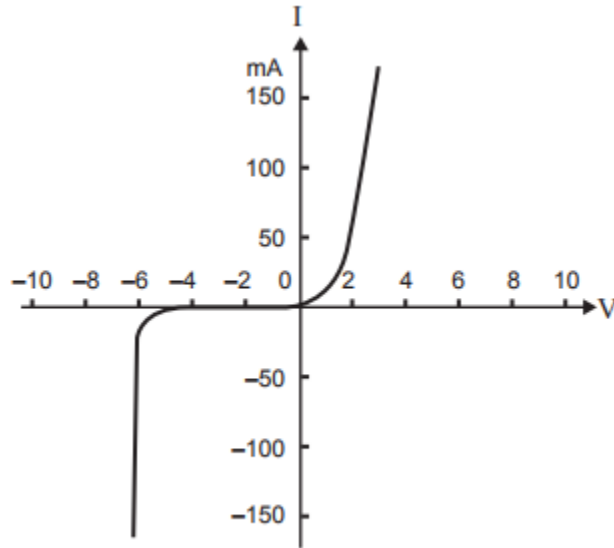

Figure 3

To test the Zener diode, they connect a 9 V DC supply to the circuit shown in Figure 4

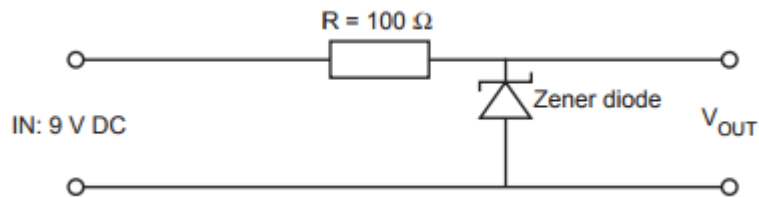

Figure 4

a. What would be the value of  $V_{OUT}$ ?

---

V

2 marks

**SECTION C** – continued

b. What would be the voltage measured across the resistor R?

---

---

|   |
|---|
| V |
|---|

2 marks

c. With no load connected across  $V_{OUT}$ , what would be the current through the Zener diode?

---

---

|    |
|----|
| mA |
|----|

2 marks

**END OF EXAMINATION**

**SECTION C: Options**

**Instructions for Section C**

Select **ONE** Option and answer **all** questions within that Option.

**Option 2.5: How do heavy things fly?**

**Question 1**

The forces between the air and the propeller of an aircraft

- A. Drive a stream of air backwards and push the propeller forwards.
- B. Drive a stream of air forwards and push the propeller forwards.
- C. Drive a stream of air backwards and push the propeller backwards.
- D. Drive a stream of air forwards and push the propeller backwards.

**Question 2**

Bernoulli's Equation can be used to explain which of the following phenomena?

- A. Lift of an airplane wing.
- B. Drag on the airplane wing.
- C. Thrust caused by the airplane's engines.
- D. The forces acting in equilibrium on an airplane.

**Question 3**

What is any surface, such as a wing, which provides aerodynamic forces when it interacts with a stream of air, called?

- A. Aileron
- B. Roll
- C. Lift
- D. Aerofoil

**SECTION C – continued**



*The following information refers to Questions 4 and 5*

Consider a rising aircraft of mass  $3 \times 10^6$  kg five seconds after take-off. The aircraft is powered by thrust of  $4.68 \times 10^5$  N and is accelerating along its line of flight.

**Question 4**

Which of the following would be the best estimate for the total lift acting on the aircraft?

- A.  $3.0 \times 10^6$  N
- B.  $2.5 \times 10^7$  N
- C.  $2.9 \times 10^7$  N
- D.  $3.0 \times 10^8$  N

**Question 5**

Which of the following would be the best estimate for the total drag acting on the aircraft?

- A.  $3.6 \times 10^5$  N
- B.  $4.68 \times 10^5$  N
- C.  $5.0 \times 10^5$  N
- D. 0 N

**Question 6 (9 marks)**

Figure 1 shows an aircraft that is flying at a constant altitude and constant velocity.



**Figure 1**

a. Indicate on Figure 1 the four main forces that act on the plane during flight

2 marks

**SECTION C – continued  
TURN OVER**

**b.** Newton’s first and third law are especially helpful when explaining the phenomena of flight. Explain how they apply.

---

---

---

---

4 marks

**c.** There are two major types of aerodynamic drag that act on a plane during its flight. Identify them and explain how they contribute to aerodynamic drag.

---

---

---

---

3 marks

**Question 7 (6 marks)**

Figure 2 shows a diagram of an aerofoil.



**Figure 2**

- a. On Figure 2 draw the motion of the air over the aerofoil. Also draw in and label the lift and angle of attack.

2 marks

- b. How does the wing create lift?

---

---

---

---

2 marks

- c. What is the angle of attack and how does it assist in lift.

---

---

---

2 marks

**END OF EXAMINATION**

**SECTION C: Options****Instructions for Section C**

Select **ONE** Option and answer **all** questions within that Option.

**Option 2.6: How do fusion and fission compare as viable energy power sources?****Question 1**

A fissile material is one that:

- A. Can never explode.
- B. Has too many electrons.
- C. Has undergone a fission reaction.
- D. Is capable of sustaining a chain reaction.

**Question 2**

The equation below shows one of the many reactions that can occur when a slow moving neutron triggers the fission of a Uranium-235 nucleus

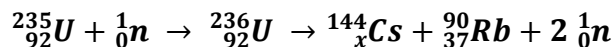

The value of  $x$  in the equation must be equal to

- A. 4
- B. 55
- C. 137
- D. 141

**Question 3**

In order to fuse, small nuclei must:

- A. Have sufficient energy to overcome the strong nuclear force and allow the Coulomb force to bring them together.
- B. Have very little kinetic energy to allow the Coulomb force to bring them together.
- C. Have very little kinetic energy to allow the strong nuclear force to bring them together.
- D. Have sufficient energy to overcome the Coulomb force of repulsion and allow the strong nuclear force to bring them together.

**SECTION C** – continued

**Question 4**

Which one of the statements **A – D** best describes the process of nuclear fusion?

- A.** Nuclear fusion is the process in which two lighter nuclei join together to form a larger, more stable nucleus.
- B.** Nuclear fusion is the process by which radioisotopes are created.
- C.** Nuclear fusion is the process by which all radioisotopes undergo radioactive decay.
- D.** Nuclear fusion is the process of splitting a suitable heavy nucleus into two lighter nuclei.

**Question 5**

What is the meaning of the term "critical mass"?

- A.** The critical element in the fuel rods.
- B.** The amount of the critical element with the fuel rods.
- C.** The amount of the critical element within the fuel rod required to sustain a chain reaction.
- D.** The amount of waste produced within the fuel rod.

**SECTION C – continued**  
**TURN OVER**

**Question 6 (6 marks)**

Figure 1 shows what can happen when the nucleus of a uranium atom absorbs a neutron.

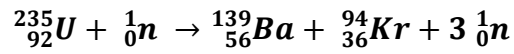

Figure 1

The release of the neutrons can then lead to subsequent reactions as shown in Figure 2.

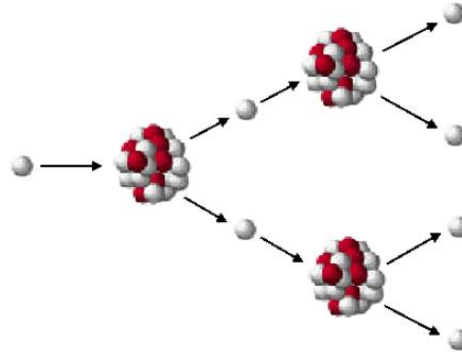

Figure 2

**a.** What is the name given to the process above?

---



---

2 marks

**b.** Explain how this process can lead to a controlled chain reaction.

---



---



---



---

2 marks

**SECTION C – continued**

c. What are the requirements for an *uncontrolled* chain reaction?

---

---

---

2 marks

**Question 7 (9 marks)**

Nuclear fission and nuclear fusion are the two methods that can be used in nuclear power stations in order to produce energy

a. What are the differences between nuclear fission and nuclear fusion in terms of the respective fuels and processes?

---

---

---

---

4 marks

b. Why are fission reactors a more viable source of energy than a fusion reactor currently?

---

---

---

---

2 marks

**SECTION C – continued  
TURN OVER**

c. However, there are advantage of fusion over fission. List three of these.

---

---

---

---

3 marks

**END OF EXAMINATION**



**SECTION C: Options**

**Instructions for Section C**

Select **ONE** Option and answer **all** questions within that Option.

**Option 2.7: How is radiation used to maintain human health?**

**Question 1**

A major advantage of MRI is;

- A. The ease with which the equipment is updated or replaced.
- B. The relative low cost compared to CT scans.
- C. Does not require a specialised room.
- D. The ability to reposition the “cross section” through the body without repositioning the body.

**Question 2**

A doctor needs 4 grams of a radiotracer to use in her hospital. If the radiotracer has a half-life of 4 hours, and takes 12 hours to deliver from the manufacturer, how much will the doctor need to order?

- A. 0.5 grams
- B. 2 grams
- C. 16 grams
- D. 32 grams

**Question 3**

The dose equivalent is

- A. The mean absorbed dose over all irradiated organs.
- B. The product of the absorbed dose and the radiation weighting factor for a given tissue or organ where the absorbed dose is averaged over the tissue or organ.
- C. The product of the absorbed dose and the tissue weighting factor.
- D. The quantity of ionising radiation absorbed by a body measured as energy absorbed per unit of mass.

**SECTION C – continued**  
**TURN OVER**

*Questions 4 and 5 relate to the following information.*

Positron emission tomography (PET) is a nuclear medical imaging technique that can be used to produce a three-dimensional image or picture of functional processes inside the body.

**Question 4**

The radioactive isotope that is injected into the patient decays by positron emission. A positron is:

- A. identical to an electron, but has a positive charge.
- B. identical to a neutron, but has a positive charge.
- C. a particle with the mass of an electron, but has the charge of a neutron.
- D. a particle with the mass of an electron and the charge of a neutron.

**Question 5**

Very soon after it is emitted a positron will meet an electron and be annihilated with it. This means that:

- A. the positron and electron form a nucleus and gamma rays are emitted.
- B. the positron and electron are destroyed and gamma rays are emitted.
- C. the positron and electron combine with the isotope to produce fluorine 18.
- D. the positron and electron combine with the isotope to produce oxygen 18.

**Question 6 (10 marks)**

Figure 1 shows an X-Ray image of a hand



**Figure 1**

**SECTION C – continued**

a. Explain how an X-ray machine produces X-rays

---

---

---

---

2 marks

b. Explain how the image is produced.

---

---

---

---

2 marks

c. Why do X-rays give good images of bones compared with soft tissue?

---

---

---

---

2 marks

**SECTION C – continued**  
**TURN OVER**

- d. X-rays can be classified as *hard* or *soft*. Explain how hard x-rays differ to soft x-rays and why they are preferred for imaging the human body.

---

---

---

---

2 marks

- e. CAT scans provide more information than X-rays, so they should be used whenever possible. Discuss this statement.

---

---

---

---

2 marks

**Question 7 (5 marks)**

Person A has a mass of 60kg. She undergoes a treatment where she receives 5 mJ of  $\beta$  radiation to the stomach

- a. Calculate the dose equivalent she receives.

---

---

|                |
|----------------|
| $\mu\text{Sv}$ |
|----------------|

2 marks

**SECTION C** – continued

2019 PHYSICS EXAM 2

Patient B undergoes a similar treatment, however, they are given a dose 1000  $\mu\text{Sv}$  to the thyroid. The weighting of the stomach is 0.12, compared to the thyroid, which is 0.05.

**b.** Who is at greater risk of developing cancer from these radiations? Explain your answer

---

---

---

---

3 marks

**END OF EXAMINATION**

**SECTION C: Options**

**Instructions for Section C**

Select **ONE** Option and answer **all** questions within that Option.

**Option 2.8: How do particle accelerators work?**

**Question 1**

Synchrotron radiation is produced when;

- A. Fast moving electrons are accelerated in a straight line.
- B. Fast moving electrons strike a metal target and stop suddenly.
- C. Fast moving electrons change directions.
- D. Fast moving electrons collide with each other.

**Question 2**

In particle accelerators;

- i. Electric fields are used to accelerate particles.
  - ii. The faster the particle the more heavier they become.
  - iii. Magnetic fields control the position of the particle.
- A. Only (i) is correct
  - B. Only (ii) is correct
  - C. (i) and (ii) are correct
  - D. All 3 statements are correct

**Question 3**

The primary purpose of a particle accelerator such as the Large Hadron Collider is to;

- A. Make small particles go very fast
- B. Make small particles achieve a large acceleration
- C. Create particles and study their behaviour
- D. Produce energy for commercial use

**SECTION C – continued**

**Question 4**

Which of the following is **not** a characteristic of light produced from a synchrotron.

- A. Highly polarised
- B. High brightness
- C. Consists of a single wavelength
- D. Tuneable

**Question 5**

Which of the following is **not** an application of particle accelerators?

- A. Implanting ions in silicon chips.
- B. Proton therapy in cancer treatment.
- C. Production of radioisotopes.
- D. Operation of LEDs

**Question 6 (8 marks)**

There have been many different particle accelerators over time. One of the earliest was a proton synchrotron that was built in the 1950's.

a. Explain how it operates.

---

---

---

2 marks

The next generation of particle accelerators consisted of cyclotrons.

b. Explain how these operate.

---

---

---

3 marks

**SECTION C – continued**

**TURN OVER**

c. Recent particle accelerators have detected many different new particles. List 3.

---

---

---

3 marks

**Question 7 (7 marks)**

a. What is the Large Hadron Collider and what is it designed to do?

---

---

---

2 marks

b. How does the LHC operate?

---

---

---

2 marks

c. Particle accelerators have also allowed scientists to confirm the standard model of particle physics with the confirmation of a specific particle. What is this particle and why was it important in confirming the standard model?

---

---

---

3 marks

**END OF EXAMINATION**



**SECTION C: Options**

**Instructions for Section C**

Select **ONE** Option and answer **all** questions within that Option.

**Option 2.9: How can human vision be enhanced?**

**Question 1**

Variation of focal length to form a sharp image on the retina is called;

- A. Accommodation
- B. Aperture
- C. Retina control
- D. Sutter

**Question 2**

To correct short sightedness the type of lens which is used is;

- A. Convex
- B. Concave
- C. Biconvex
- D. Flat lenses

**Question 3**

The lens in the human eye is;

- A. Concave
- B. Convex
- C. Biconcave
- D. Biconvex

**SECTION C – continued**  
**TURN OVER**

**Question 4**

Hypermetropia is rectified by using a:

- A. Convex lens
- B. Concave lens
- C. Cylindrical lens
- D. Progressive lens

**Question 5**

An object is placed 30 cm in front of a diverging lens with a focal length 10 cm. What is the magnification?

- A. 0.25
- B. 0.67
- C. -0.25
- D. -0.67

**Question 6 (10 marks)**

There are a variety of different conditions that impact how the eye functions

- a. What type of vision impairment is represented in Figure 1? How is this corrected?

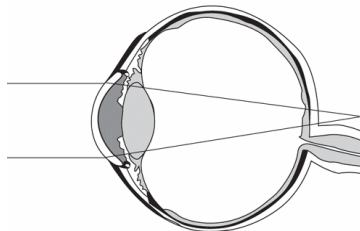

Figure 1

---

---

---

---

3 marks

**SECTION C** – continued

b. What type of vision impairment is represented in Figure 2? How is this corrected?

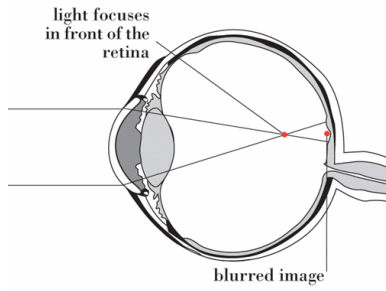

Figure 2

---

---

---

3 marks

c. What is astigmatism and how is it corrected?

---

---

---

---

2 marks

d. What happens to your vision as you age? How is this corrected?

---

---

---

---

2 marks

**SECTION C – continued**  
**TURN OVER**

**Question 7 (5 marks)**

Figure 3 shows a man looking at a fish in a pond.

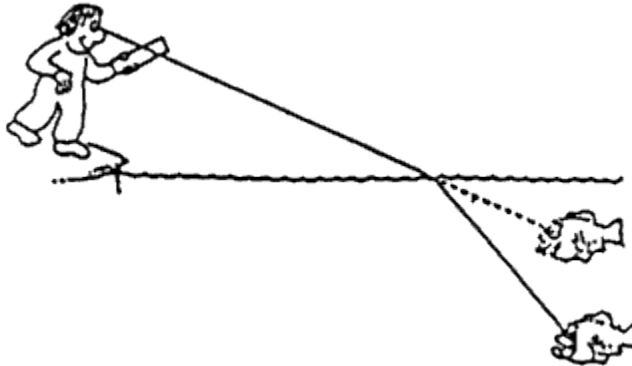

Figure 3

a. Explain why the fish appears to be in a different location than it actually is.

---

---

---

---

2 marks

b. If the man's line of sight makes an angle of  $30^\circ$  to the water's surface and the water has a refractive index of 1.33, find the angle of refraction for the image of the fish.

---

---

---

3 marks

|   |
|---|
| ○ |
|---|

**END OF EXAMINATION**

**SECTION C: Options**

**Instructions for Section C**

Select **ONE** Option and answer **all** questions within that Option.

**Option 2.10: How do instruments make sound?**

**Question 1**

A wave of wavelength 20 m is travelling at  $500 \text{ m s}^{-1}$ . Its period will be;

- A. 0.2 s
- B. 0.05 s
- C. 25 s
- D. 0.04 s

**Question 2**

Which of the following is **not** normally discussed as a characteristic of a musical sound?

- A. Pitch
- B. Wavelength
- C. Quality
- D. Loudness

**Question 3**

Which of the following determines the pitch of a sound?

- A. The amplitude of the sound wave
- B. The distance of the sound wave from the source
- C. The frequency of the sound wave
- D. The speed of the sound wave

**SECTION C – continued**  
**TURN OVER**

**Question 4**

Virtually all musical instruments depend on resonance. Which of these best describe what is meant by resonance?

- A. The superposition principle which says that the overall distance of a wave is the vector addition of the individual displacements of separate waves.
- B. When waves coming from two or more sources reach the same region they will combine in such a way to cause constructive or destructive interference
- C. Waves trapped in a confined space will always interfere with each other to form a bigger wave
- D. Waves trapped in a confined source will sometimes interfere with each other to produce a standing wave

**Question 5**

The graph in Figure 1 shows the relationship between sound intensity level (dB), frequency (Hz) and loudness (phon) as perceived by Lexi.

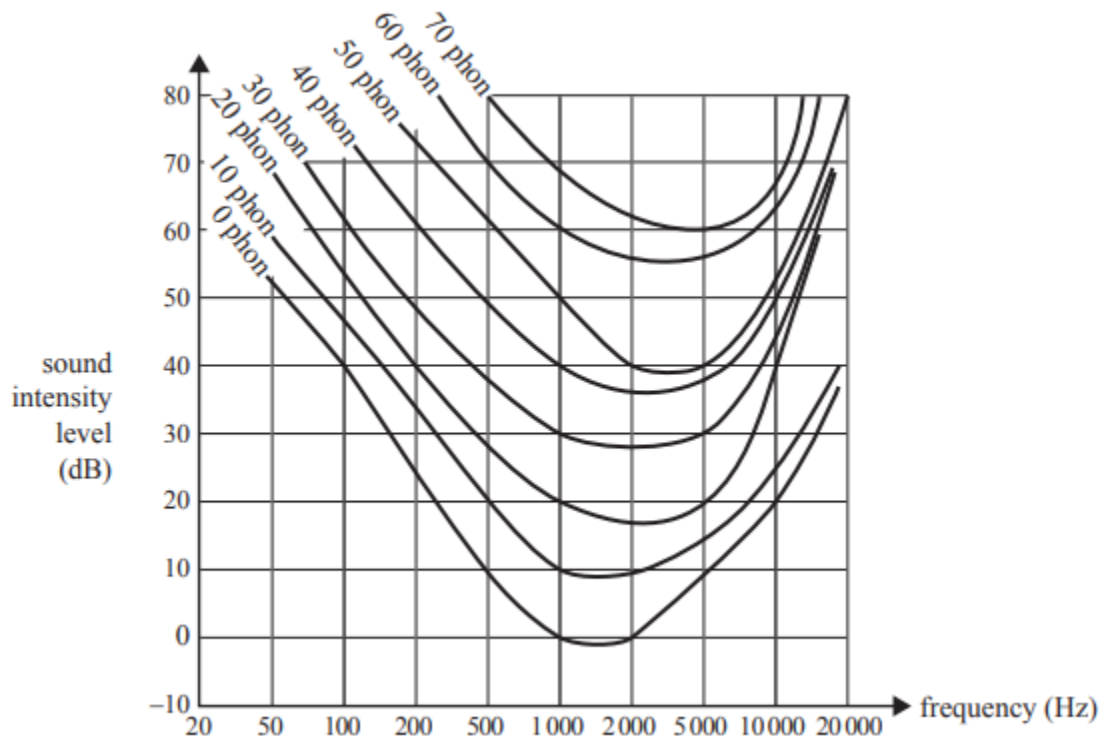

Figure 1

**SECTION C – continued**

With the frequency of the sound at 5000 Hz, the loudspeaker's volume is adjusted so that the sound intensity level is 40 dB. Which of the following is the best estimate of the loudness of the sound according to Lexi?

- A. 20 phon
- B. 30 phon
- C. 40 phon
- D. 50 phon

**Question 6 (11 marks)**

Students are investigating two different instruments a flute and a clarinet as shown in Figure 2. They model the flute by using an open both ends pipe of length 55cm and the clarinet by using a closed one end pipe of the same length and sit an amplifier next to one end so they can send down a sound down each pipe and adjust the frequency of the sound within the pipe.



Figure 2

They notice that at particular frequencies in both the open and closed pipe they can hear distinctly louder sounds.

- a. Explain why they hear distinctly louder sounds at some frequencies but not others.

---

---

2 marks

- b. Assuming the speed of sound in air is  $340 \text{ m s}^{-1}$  what is the fundamental frequency in the open both ends pipe.

---

---

2 marks

|  |    |
|--|----|
|  | Hz |
|--|----|

**SECTION C – continued**

c. What are the next two frequencies heard within this pipe?

---

---

|    |    |
|----|----|
| Hz | Hz |
|----|----|

2 marks

d. The students now investigate the closed one end pipe in the same way. Find the first three frequencies they hear.

---

---

|    |    |    |
|----|----|----|
| Hz | Hz | Hz |
|----|----|----|

3 marks

e. Explain why the frequencies are different in open and closed pipes.

---

---

---

---

2 marks

**SECTION C** – continued



**Question 7 (4 marks)**

In order for a human to detect sounds the ear must be able to function in such a way that the incoming sound waves are detected and converted to electrical signals to pass through to our brains to detect and interpret. Figure 3 shows a label diagram of an ear.

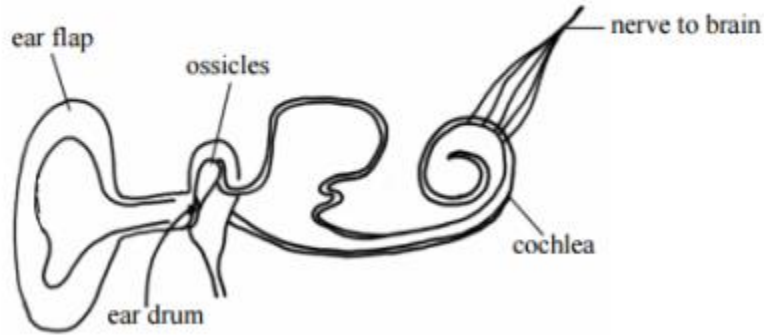

Figure 3

a. What is the function of the ear drum in the conversion process?

---

---

---

---

2 marks

b. Explain how the cochlea functions in the conversion process.

---

---

---

2 marks

**END OF EXAMINATION**

**SECTION C: Options**

**Instructions for Section C**

Select **ONE** Option and answer **all** questions within that Option.

**Option 2.11: How can performance in ball sports be improved?**

**Question 1**

When a falling object reaches terminal velocity it is;

- A. No longer subject to the friction of the air
- B. Moves downwards with constant velocity
- C. Has an acceleration of  $9.8 \text{ ms}^{-2}$
- D. Has no downwards velocity

**Question 2**

When a falling object reaches terminal velocity it is;

- A. No longer subject to the friction of the air
- B. Moves downwards with constant velocity
- C. Has an acceleration of  $9.8 \text{ ms}^{-2}$
- D. Has no downwards velocity

*The following information refers to Questions 3 and 4*

A ball of mass 50 grams is dropped vertically from a height of 2 m onto a smooth flat surface. The coefficient of restitution between the ball and the surface is 0.7.

**Question 3**

What will be the height of the ball after the third bounce?

- A. 0.98 m
- B. 0.67 m
- C. 0.48 m
- D. 0.24 m

**SECTION C – continued**

**Question 4**

What will be the velocity of the ball after the third bounce?

- A.  $2.15 \text{ m s}^{-1}$
- B.  $3.06 \text{ m s}^{-1}$
- C.  $4.38 \text{ m s}^{-1}$
- D.  $6.26 \text{ m s}^{-1}$

**Question 5**

In a game of baseball a ball is thrown horizontally to the left at the batter with a velocity of  $10 \text{ m s}^{-1}$ . He strikes the ball and it leaves the bat horizontally to the right with a velocity of  $15 \text{ m s}^{-1}$ . The change in the velocity of the ball will be equal to:

- A.  $25 \text{ m s}^{-1}$  right
- B.  $25 \text{ m s}^{-1}$  left
- C.  $5 \text{ m s}^{-1}$  right
- D.  $5 \text{ m s}^{-1}$  left

**Question 6 (10 marks)**

A golfer drives her ball from the tee down the fairway in a high arcing shot. The ball is struck with an initial velocity of  $40 \text{ m s}^{-1}$  at an angle of  $20^\circ$  to the horizontal and travels a parabolic path. (Ignore any effect of the air acting on the ball.)

a. What is the maximum height of the ball?

---

|   |         |
|---|---------|
| m | 2 marks |
|---|---------|

b. How long was the ball in the air?

---

|   |         |
|---|---------|
| s | 2 marks |
|---|---------|

**SECTION C – continued  
TURN OVER**

c. If the hole is 110 m away from the tee, how far from the hole will the ball land?

---

---

|   |         |
|---|---------|
| m | 3 marks |
|---|---------|

The ball was in fact hit with backspin and as a result is under the influence of the Magnus Effect.

d. Explain what the Magnus Effect is and what effect it produced on the golf ball.

---

---

---

---

---

3 marks

**Question 7 (5 marks)**

To throw a curve ball a pitcher gives the ball an initial angular speed of 36 radians per second. When the catcher gloves the ball 0.6 s later the ball's angular speed has decreased due to air resistance to 34 radians per second.

- a. What is the ball's angular acceleration?

---

2 marks

- b. How many revolutions did the ball make before it was caught?

---

3 marks

**END OF EXAMINATION**

**SECTION C: Options**

**Instructions for Section C**

Select **ONE** Option and answer **all** questions within that Option.

**Option 2.12: How does the human body use electricity?**

**Question 1**

The firing of a neuron is called;

- A. Depolarisation
- B. An action potential
- C. Both of the above
- D. None of the above

**Question 2**

Each neuron has approximately how many synapses?

- A. 1 – 100
- B. 10 – 1000
- C. 100 – 10 000
- D. 1000 – 100 000

**Question 3**

Which of these statements in regard to the conduction of the heart system is true?

- A. The initial action potential starts in the atria-ventricular node
- B. The SA node stimulates the action potential along the fibres of His
- C. The fibres of His propagate the signal across to the ventricles
- D. The atria directly stimulates the ventricles

**SECTION C – continued**

**Question 4**

Defibrillation is the process where for a few milliseconds a direct current of about;

- A. 6A is applied directly to the heart through a conducting path that bypasses the skin
- B. 100 mA is applied to the chest wall through 2 paddles
- C. 6A is applied to the chest wall though 2 paddles
- D. 100 mA is applied directly to the heart through a conducting path that bypasses the skin

**Question 5**

Electrical signals that control the rhythm of the heart beat can be measured by an

- A. ECG
- B. EEG
- C. EMG
- D. ECT

**Question 6 (6 marks)**

Electricity within our brains is the key to our survival.

- a. Explain why this is the case.

---

---

---

2 marks

- b. How are electrical signals sent from the brain though the body?

---

---

---

2 marks

**SECTION C – continued  
TURN OVER**

c. How does the body create these electrical signals?

---

---

---

---

2 marks

**Question 7 (6 marks)**

A neuron is stimulated with an electric pulse. The action potential is detected at a point 3.40 cm down the axon 0.0052 s later. When the action potential is detected 7.20 cm from the point of stimulation, the time required is 0.0063 s.

a. What is the speed of the electric pulse along the axon and why are two measurements needed instead of only one?

---

---

---

---

2 marks

|                   |
|-------------------|
| $\text{m s}^{-1}$ |
|-------------------|

b. How is an electrical impulse generated in a neuron?

---

---

---

---

2 marks

**SECTION C – continued**



c. How is the signal transmitted through the neuron?

---

---

---

---

2 marks

**Question 8 (3 marks)**

One of the most common electric currents in our body is our heart rhythm. Explain how this current functions in relation to the sodium, potassium and calcium ions.

---

---

---

---

3 marks

**END OF EXAMINATION**

## Formula and Data Sheet

|  |  |
|--|--|
| Velocity; acceleration   | $v = \frac{\Delta s}{\Delta t}; a = \frac{\Delta v}{\Delta t}$   |
| Equations for constant acceleration                                  | $s = ut + \frac{1}{2}at^2$ $s = vt - \frac{1}{2}at^2$ $s = \frac{1}{2}(u + v)t$ $v = u + at$ $v^2 = u^2 + 2as$ |
| Newton's second law  | $a = \frac{F_{net}}{m}$  |
| Torque   | $\tau = r_{\perp}F$  |
| Gravitational potential energy changes near the surface of the Earth | $E_g = mg\Delta h$   |
| Force in springs   | $F = -k\Delta x$   |
| Elastic potential energy   | $E_s = \frac{1}{2}k\Delta x^2$   |
| Kinetic energy   | $E_k = \frac{1}{2}mv^2$  |
| Mechanical work  | $W = Fd$   |
| Efficiency of energy transfer  | $\eta = \frac{\text{useful energy out}}{\text{total energy in}}$   |
| Power  | $P = \frac{W}{t}$  |
| Momentum; impulse  | $p = m\Delta v; I = F\Delta t$   |
| Gravitational field strength near the surface of the Earth           | $g = 9.8 \text{ N kg}^{-1}$  |

|                      |  |
|----------------------|--|
| Electric power       | $V = IR; P = VI$   |
| Speed of light       | $c = 3.0 \times 10^8 \text{ m s}^{-1}$                                   |
| Wave speed           | $v = f\lambda$   |
| Doppler shift        | $\frac{\Delta\lambda}{\lambda_0} = \frac{v}{c}$                          |
| Mass-energy equation | $E = mc^2$   |
| Centre of mass       | $x_m = \frac{x_1m_1 + x_2m_2 + \dots + x_nm_n}{m_1 + m_2 + \dots + m_n}$ |
| Stress               | $\sigma = \frac{F}{A}$   |
| Strain               | $\varepsilon = \frac{\Delta L}{L}$                                       |
| Young's modulus      | $E = \frac{\sigma}{\varepsilon}$   |
| Transformer          | $\frac{N_1}{N_2} = \frac{V_1}{V_2}$                                      |
| Time constant        | $\tau = RC$  |
| Capacitance          | $C = \frac{Q}{V}$  |
| Bernoulli's equation | $P_1 + \rho v_1^2 A = P_2 + \rho v_2^2 A$                                |
| Lift                 | $F_L = \frac{1}{2} C_L \rho v^2 A$                                       |
| Drag                 | $F_D = \frac{1}{2} C_D \rho v^2 A$                                       |
| Power                | $P = Fv$   |
| Electron volt        | $1 \text{ eV} = 1.602\,176 \times 10^{-19} \text{ J}$                    |

|                            |  |
|----------------------------|--|
| Absorbed dose              | $\text{absorbed dose} = \frac{\text{energy absorbed}}{\text{mass}}$          |
| Equivalent dose            | $\text{equivalent dose} = \text{absorbed dose} \times \text{quality factor}$ |
| Snell's law                | $n_1 \sin(\theta_1) = n_2 \sin(\theta_2)$                                    |
| Image position             | $\frac{1}{f} = \frac{1}{u} + \frac{1}{v}$                                    |
| Image size                 | $\frac{H_i}{H_o} = \frac{v}{u}$  |
| Sound intensity            | $I = \frac{P}{4\pi d^2}$   |
| Sound intensity level      | $L = 10 \log_{10} \left( \frac{I}{1 \times 10^{-12}} \right)$                |
| Coefficient of restitution | $e = \frac{v - V}{U - u}$  |
| Linear and angular speed   | $v = r\omega$  |
| Rolling friction           | $F_k = \mu N$  |

**Prefixes/Units**

|                       |                      |                           |                       |
|-----------------------|----------------------|---------------------------|-----------------------|
| p = pico = $10^{-12}$ | n = nano = $10^{-9}$ | $\mu$ = micro = $10^{-6}$ | m = milli = $10^{-3}$ |
| k = kilo = $10^3$     | M = mega = $10^6$    | G = giga = $10^9$         | t = tonne = $10^3$ kg |