

SECTION A – Multiple Choice Questions

Instructions for Section A

Answer **all** questions in pencil on the answer sheet provided for multiple choice questions.

Choose the response that is **correct** and that **best answers** the question.

A correct answer **scores** 1; an incorrect answer scores 0.

Marks will not be deducted for incorrect answers.

Unless indicated the diagrams in this book are **not** drawn to scale.

Take the value of g to be 9.8 m s^{-2} .

Question 1

Figure 1 shows the electric field near two point charges L and R.

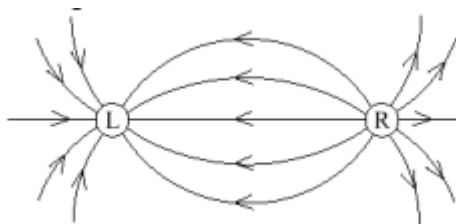

Figure 1

What is the polarity of each charge?

- | Charge L | Charge R |
|--------------------|-----------------|
| A. Positive | Positive |
| B. Negative | Positive |
| C. Positive | Negative |
| D. Negative | Negative |

Question 2

A negative charge in an electric field experiences a force accelerating it due south. What is the direction of the electric field?

- A.** East
- B.** West
- C.** North
- D.** South

SECTION A – continued

PHYS EXAM

Question 3

Masses of M and $2M$ exert a gravitational force F on each other when the distance between their centres is r . What is the gravitational force between masses of $2M$ and $4M$ when the distance between their centres is $4r$?

- A. $0.25 F$
- B. $0.50 F$
- C. $0.75 F$
- D. $1.00 F$

Question 4

As a comet orbits the Sun the distance between the comet and the Sun continually changes. As the comet moves towards the Sun this distance reaches a minimum value. Which one of the following statements is incorrect as the comet approaches this minimum distance?

- A. The potential energy of the comet increases.
- B. The gravitational force acting on the comet increases.
- C. The direction of the gravitational force acting on the comet changes.
- D. The kinetic energy of the comet increases.

Question 5

The tension in a string from which a 4.0 kg object is suspended in an elevator is equal to 44N . What is the acceleration of the elevator?

- A. 11 m s^{-2} upward
- B. 1.2 m s^{-2} downward
- C. 1.2 m s^{-2} upward
- D. 2.4 m s^{-2} downward

Question 6

Which one of the following best describes the term proper time?

- A. The time as measured by an atomic clock.
- B. The time when measured by any observer at the same location.
- C. The time when measured at rest relative to the event.
- D. The time when measured whilst moving at a constant speed away from the event.

Question 7

Which one of the following situations would NOT be suitable for confirming Newton's Laws of Motion?

- A. Travelling through deep space at a constant speed of $0.95c$.
- B. At rest in a craft in deep space.
- C. Inside the shell of a rotating craft in deep space (radius of 100 m , period of rotation of 4 sec).
- D. In space travelling at a constant speed of $0.1c$.

SECTION A – continued
TURN OVER

The following information refers to Questions 8 and 9

Question 8

Which of the following is the best estimate of the speed of the electron that would be required for a radius of curvature of 0.1 m within a magnetic field of 4.2×10^{-3} T?

- A. 7.4×10^6 m s⁻¹
- B. 3×10^8 m s⁻¹
- C. 1.35×10^8 m s⁻¹
- D. 7.4×10^7 m s⁻¹

Question 9

If the electron referred to in Question 8 were to move in a clockwise circular path (in the plane of this page), which direction would the magnetic field need to be directed?

- A. Clockwise.
- B. Anticlockwise.
- C. Into the page.
- D. Out of the page.

Question 10

Which of the following is NOT a transverse wave?

- A. Light.
- B. Radio wave.
- C. Sound.
- D. All of the above.

Question 11

Which of the following properties is NOT a characteristic of the light from a laser?

- A. The waves all have the same frequency.
- B. The waves are all in phase with one another.
- C. The waves form a narrow beam.
- D. The waves have higher photon energies than light waves of the same frequency from an ordinary source.

Question 12

The wavelength of an electromagnetic wave is 600 nm. What is its frequency?

- A. 2×10^{14} Hz
- B. 3×10^{14} Hz
- C. 4×10^{14} Hz
- D. 5×10^{14} Hz

SECTION A – continued

The following information refers to Questions 13 and 14

A student is investigating resonance in a tube which is open at one end only. A microphone is placed at the closed end and moves towards the open end. At 0.8 m from the closed end, it detects the first quiet point. You may assume the speed of sound in the air in the tube is 340 m s^{-1} . Figure 2 details the dimensions of the setup.

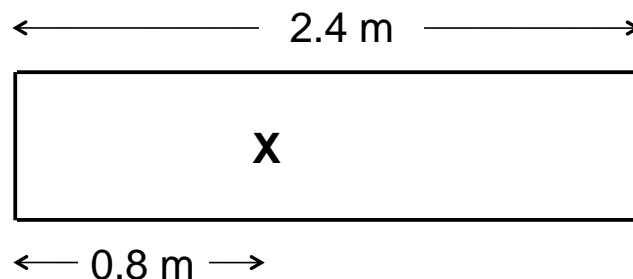

Figure 2

Question 13

Which of the following best approximates the wavelength of the resonant frequency which is being detected by the microphone?

- A. 71 Hz
- B. 106 Hz
- C. 212 Hz
- D. 425 Hz

Question 14

Which of the following is the correct terminology for the resonant frequency that is being detected by the microphone in Question 12?

- A. Fundamental, 1st Harmonic
- B. 2nd Harmonic
- C. 3rd Harmonic
- D. 5th Harmonic

Question 15

In an electromagnetic wave, the direction of the magnetic field:

- A. Will be parallel to the direction of the electric field.
- B. Will be perpendicular to the direction of the electric field.
- C. Will be parallel to the direction of travel of the wave.
- D. Will be randomly oriented with respect to the direction of the electric field.

**SECTION A – continued
TURN OVER**

PHYS EXAM

Question 16

When a light ray passes from zircon ($n=1.923$) into fluorite ($n = 1.434$) at an angle of 60° , its path is

- A. Bent toward the normal.
- B. Bent away from the normal.
- C. Parallel to the normal.
- D. Not bent.

Question 17

An electron can revolve in an orbit around a nucleus with radiating energy provided that the orbit

- A. Is far enough away from the nucleus.
- B. Is less than a de Broglie wavelength in circumference.
- C. Is a whole number multiple of de Broglie wavelengths in circumference.
- D. Is a perfect circle.

Question 18

Which of the following is *true* about the uncertainty principle?

- A. The uncertainty principle is an important relationship between position and momentum.
- B. The uncertainty principle is an important relationship between energy and time.
- C. The uncertainty principle is an important relationship between energy and position.
- D. The uncertainty principle helped prove the idea of strict physics.

Question 19

A transformer is a device that used in;

- A. DC circuit.
- B. AC circuit.
- C. DC motor.
- D. Both A and B.

Question 20

A transformer has an input of 110 DC volts, with 100 turns on the primary and 10 turns on the secondary. What is the output voltage?

- A. 1100 V
- B. 110 V
- C. 11 V
- D. 0 V

END OF SECTION A

SECTION B

Instructions for Section B

Answer **all** questions in the spaces provided. Write using blue or black pen
Where an answer box is provided, write your full answer in the box.
If an answer box has a unit provided in it, give your answer in that unit.
In questions where more than one mark is available, appropriate working **must** be shown.
Unless indicated the diagrams in this book are **not** drawn to scale.
Take the value of g to be 9.8 m s^{-2}

Question 1 (3 marks)

An electron moves parallel to, but in an opposite direction to a uniform electric field as shown in **Figure 1**

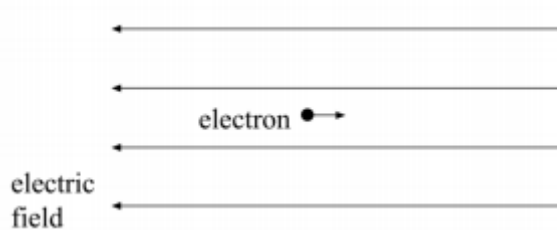

a. State the direction of the force that acts on the electron due to the the electric field.

1 mark

b. What is the effect of this force on the electron?

2 marks

SECTION B – continued
TURN OVER

Question 2 (5 marks)

An electron travels at a speed of $3.2 \times 10^7 \text{ m s}^{-1}$ in a horizontal path through a vacuum. The electron enters a uniform electric field between two parallel plates 30 mm long and 15 mm apart as shown in **Figure 2**. A potential difference of 1400 V is maintained across the plates with the top plate having positive polarity.

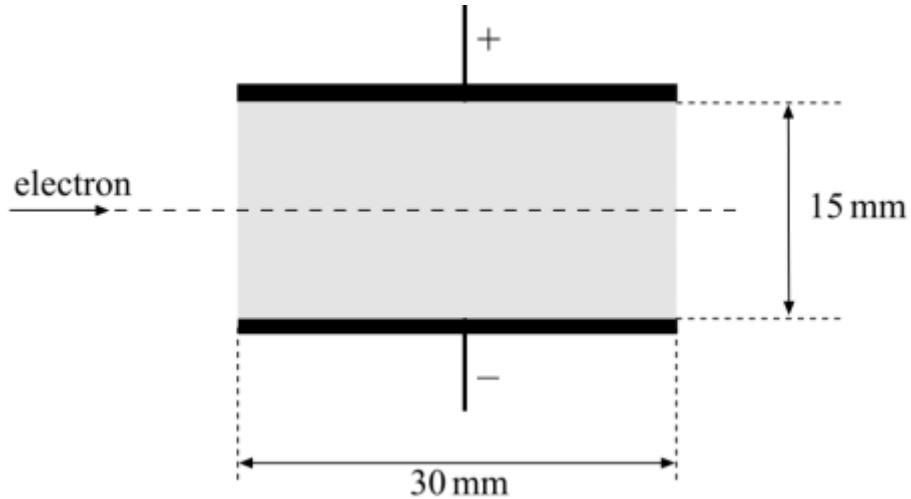

Figure 2

- a.** Show the electric field strength is $9.3 \times 10^4 \text{ V m}^{-1}$. 2 marks

- b.** Determine the magnitude and the direction of the acceleration of the electron whilst in the field, including its direction 3 marks

m s^{-2}	Direction:
-------------------	------------

SECTION B – continued

Question 3 (6 marks)

Not satisfied with theoretical discussions about gravitation, a physics class launches a manned orbiter around nearby planet Tritonus. Known data for the planet and the orbiter is shown in **Figure 3**:



Figure 3

- **Mass of orbiter:** $7.2 \times 10^3 \text{ kg}$
- **Mass of Tritonus:** $2.9 \times 10^{23} \text{ kg}$
- **Radius of Tritonus:** $2.4 \times 10^6 \text{ m}$

At a particular orbit, the force of Tritonus on the orbiter is known to be $2.06 \times 10^4 \text{ N}$.

- a. Determine the altitude of the orbiter above the surface of Tritonus. 2 marks

m

- b. Determine the period of orbit for the craft. State your answer to the nearest minute. 2 marks

mins

SECTION B – Question 3 - continued
TURN OVER

PHYS EXAM

Class observers based at Mission Control on Earth are discussing the effect of gravity on the occupants of the orbiter.

- Carrie asserts that the occupants are weightless as their circular orbit effectively means they are in freefall around Tritonus. All gravitational forces are simply acting on the orbiter alone.
 - Bill disagrees and says that the occupants would feel weightless, but that the magnitude of the weight force acting on them remains constant and definitely not zero.
- c. Discuss the accuracy of Carrie and Bill's statements, referring to appropriate physics concepts to support your answer. 2 marks

SECTION B – continued

Question 4 (6 marks)

A solenoid and bar magnet are positioned as shown in **Figure 4**. A DC battery powers the solenoid.

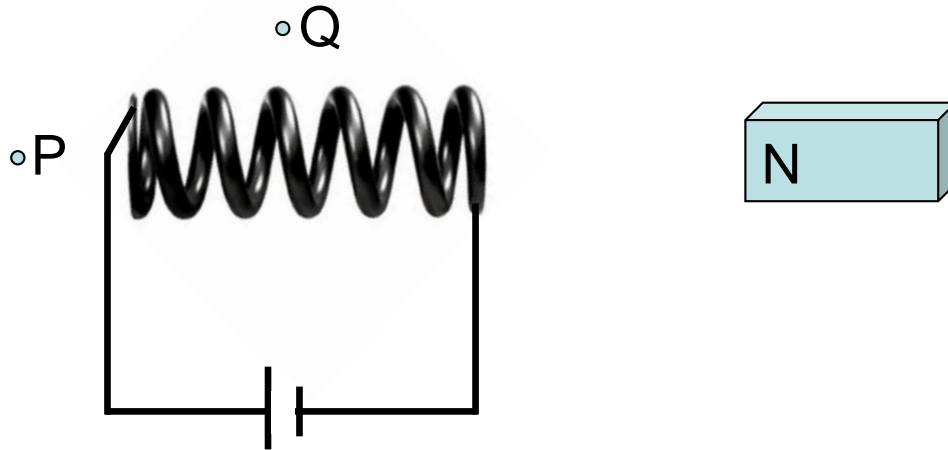

Figure 4

- a. Using Figure 4 as a template, sketch three field lines for both the bar magnet and the solenoid to indicate the magnetic field pattern that would be produced. 2 marks
- b. Which of the following best describes the direction of the magnetic field at Point Q (Figure 4)? 1 mark
- A. Left
 - B. Right
 - C. Up
 - D. Down
 - E. Into the page
 - F. Out of the page

Direction:

SECTION B – Question 4 - continued
TURN OVER

PHYS EXAM

A copper wire is positioned so that it runs perpendicular to the page at point P (see Figure 4). When the solenoid carries current, 4 cm of wire experiences a force of 0.08 N upwards. The magnetic field strength of the solenoid is 0.6 T in the vicinity of the wire.

- c. Determine the magnitude and direction of the current through the copper wire. 3 marks

A

Direction:

SECTION B – continued

Question 5 (7 marks)

Figure 5 shows a truck and trailer moving down an inclined plane with a gradient of 10° . The truck has a mass of 7×10^3 kg and the trailer 3×10^3 kg. You may ignore the mass of the coupling joining the two.

The truck driver is applying the brakes such that the truck is accelerating at 2 m s^{-2} down the slope..

Friction forces equal to 15% of the truck and trailer weight are also acting on each, respectively (braking force not included).

There is a compression force in the coupling between the trailer and truck equal to 4000 N.

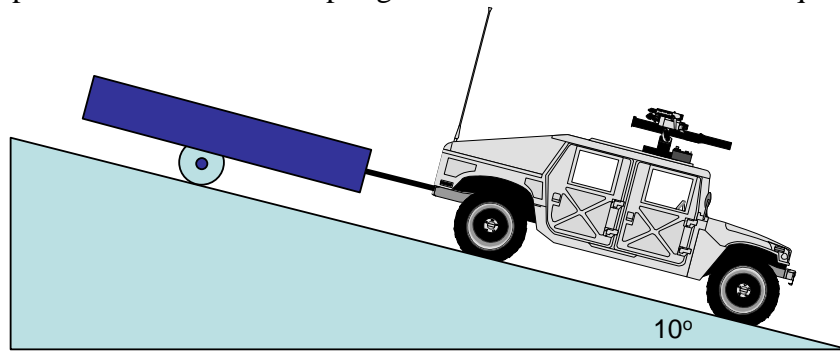

Figure 5

- a. Label the key forces acting on the truck.

Use the convention $F_{\text{object A on object B}}$.

2 marks

- b. Determine the net force acting on the truck.

2 marks

N

SECTION B – Question 5 - continued
TURN OVER

c. Determine the braking force required by the truck.

3 marks

N

SECTION B – continued

Question 6 (7 marks)

Ivan the Physics Giant is pushing boxes along a rough carpet surface, just for fun.

There are two boxes:

- **Box A – 20 kg**
- **Box B – 10 kg**

At one point in the game, Ivan pushes the boxes at a constant speed.

Sliding friction of 50% of the weight is known to act on both boxes.

Figure 6 shows Ivan and the boxes.

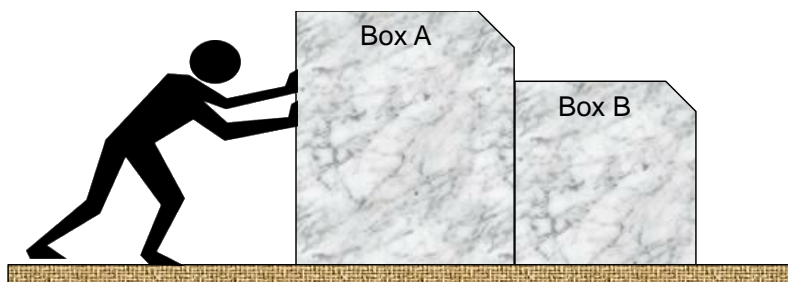

Figure 6

a. Determine the size of $F_{\text{Ivan on Box A}}$.

2 marks

N

b. Label and calculate the size of each of the key forces acting on Box B. Use the convention $F_{\text{object A on object B}}$.

2 marks

c. Determine the size and direction of $F_{\text{Box B on Box A}}$.

3 marks

N	Direction:
---	------------

**SECTION B – continued
TURN OVER**

Question 7 (8 marks)

There is a new ride at the local playground which involves a rider sitting in a chair that is attached to a pole via a cable. The pole then rotates so that the rider moves in a circle, as shown in **Figure 7**.

An anxious parent observes their child excitedly sitting in the chair as it revolves around the central pole with a period of 3.1 sec.

The horizontal distance from the chair to the pole is 3.5 m.

The chair and child have a combined mass of 25 kg.

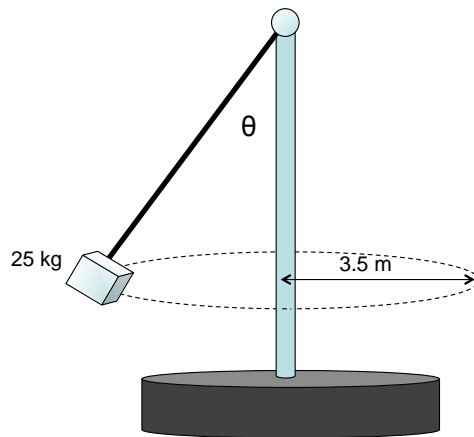

Figure 7

a. Determine the speed of the child.

1 mark

m s^{-1}

b. Determine the net force acting on the child and chair (as a combined mass). 2 marks

N

SECTION B – Question 7 - continued

PHYS EXAM

- c. Calculate the size of the tension force in the cable connecting the chair and the central pole. 3 marks

N

The parent now increases the speed of the ride and carefully observes the effect on the chair and child.

- d. Which **one or more** of the following would occur? 2 marks

- A. The period would increase.
- B. The radius (horizontal distance from chair to central pole) would increase.
- C. The net force on the chair and child would increase.
- D. The angle that the cable makes with the central pole (shown as θ in Figure 7) would increase.

--

SECTION B – continued
TURN OVER

Question 8 (4 marks)

Consider a projectile launched from ground level to a raised shelf, as shown in **Figure 8**. The shelf is 16.2 m above the ground and an observer notes that the projectile is launched at an angle of 35° and reaches its top with only horizontal velocity. The trajectory takes 1.8 sec and air resistance can be ignored during your calculations.

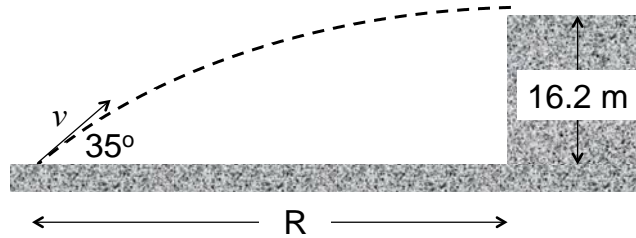

Figure 8

a. Determine the speed of the projectile at launch, v .

2 marks

m s^{-1}

b. Determine the distance from the launch point to the based of the shelf (shown as **R** in Figure 5).

2 marks

m

SECTION B – continued

Question 9 (4 marks)

Two carts are positioned on what can be assumed to be a frictionless air-track, as shown in Figure 9. A magnet is fixed to the end of each cart with the like poles facing each other (ie. so a repulsive force is experienced).

The carts are brought together, then released from rest at $t = 0$ sec.

The following data may be used:

- Mass of Cart A: 0.35 kg
- Mass of Cart B: 0.20 kg

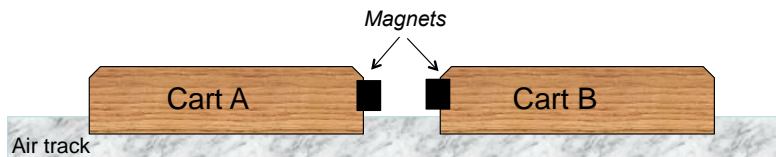
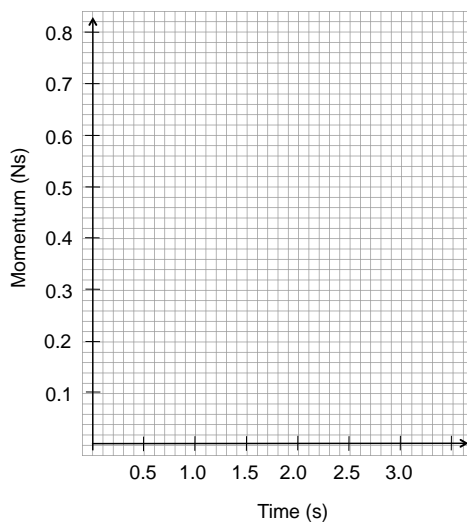

Figure 9

a. Draw a graph showing the total momentum of the system over time.

2 marks



Cart A is measured with a velocity of 1.3 m s^{-1} as it moves away after being released.

b. Determine the kinetic energy of Cart B.

2 marks

J

**SECTION B – continued
TURN OVER**

Question 10 (7 marks)

A 20.0 m long bus drives past a person standing on the side of the road with a velocity of $0.9c$ as shown in **Figure 10**.

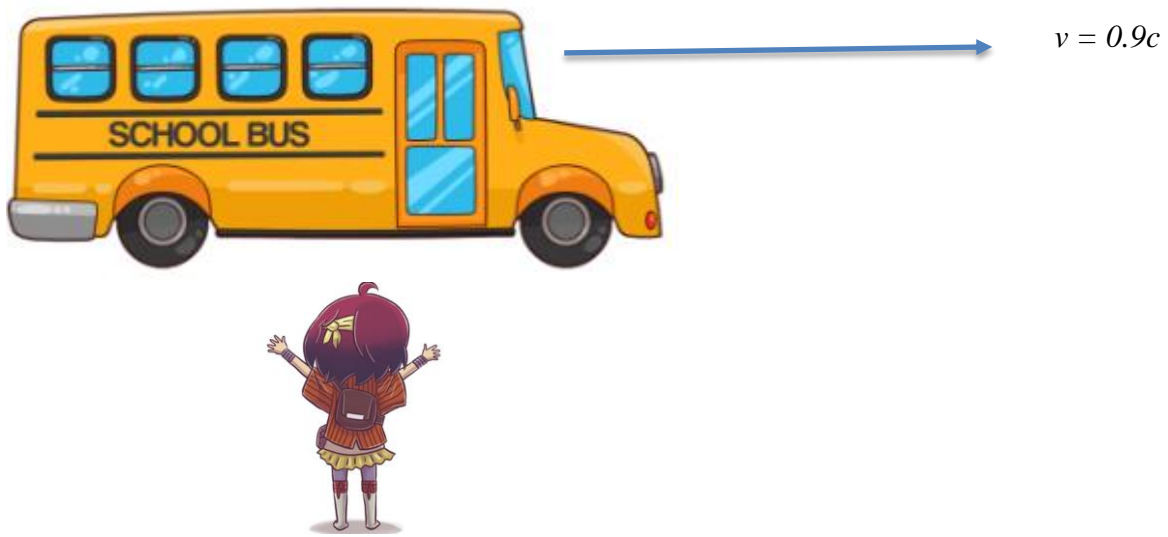

Figure 10

- a. How long will the bus look to the person on the road? 3 marks

m

- b. How much time does the person on the road say it takes for the entire bus to pass her? 2 marks

s

SECTION B – continued

- c. How much time do two people on the bus (one at the front, one at the back) say it takes to pass her? 2 marks

s

Question 11 (4 marks)

Figure 11 shows a coil of 10 turns as a basic generator positioned horizontally between a pair of bar magnets, which provide a constant magnetic field strength of 0.4 T. The coil has an area of 0.3 m^2 and can be assumed to be immersed in the field of the bar magnets at all times.

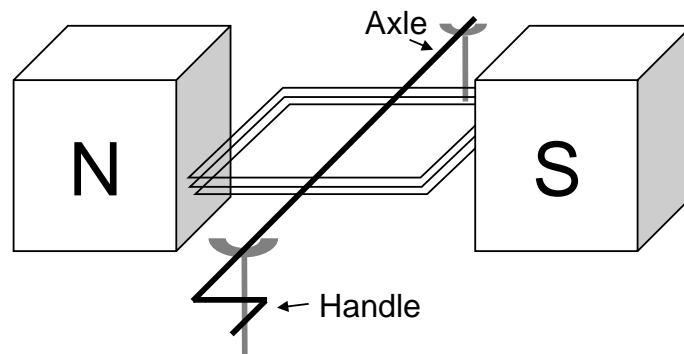

Figure 11

- a. Determine the size of the magnetic flux through the coil as shown in Figure 13. 2 marks

Wb

SECTION B – Question 11 - continued
TURN OVER

PHYS EXAM

The coil is now rotated clockwise through a quarter of one revolution.
The average voltage generated during the movement is 4 V.

- b.** Determine the time interval required to generate an average of 4 V in a quarter turn.

2 marks

s

SECTION B – continued
TURN OVER

Question 12 (7 marks)

Figure 12 shows a solenoid, which is connected to a variable voltage supply and positioned near a circular copper loop (area = 0.3 m^2). The voltage in the solenoid is initially zero. You may assume that the magnetic field from the solenoid varies directly with the voltage, with 4V corresponding to 0.4 T.

From $t = 0$, the voltage is adjusted according to the graph shown in **Figure 13**.

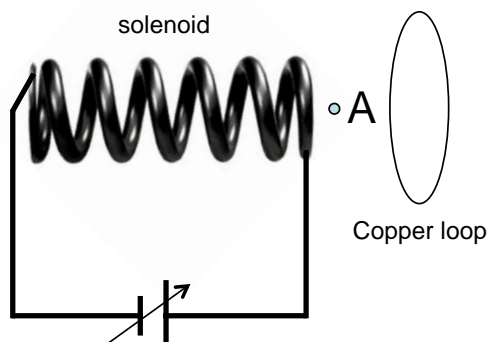

Figure 12

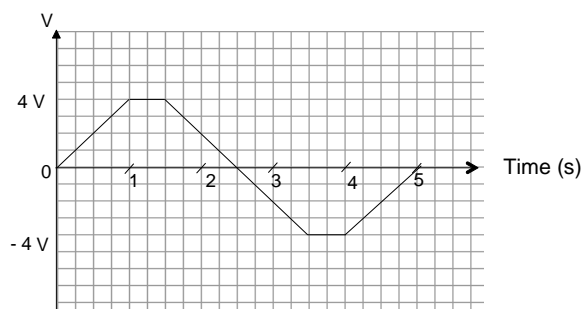

Figure 13

- a. Determine the direction of the current induced in the copper loop over the first 1 second, as viewed from Point A (Figure 5). Explain how you arrived at your answer. 3 marks

Direction: Clockwise / Anticlockwise

SECTION B – Question 12 - continued
TURN OVER

PHYS EXAM

- b. Using the axes provided below, sketch a graph of flux and emf in the loop as the voltage in the solenoid varies. Label the vertical axes with appropriate scales. The original voltage vs. time graph has been included for reference purposes. 4 marks

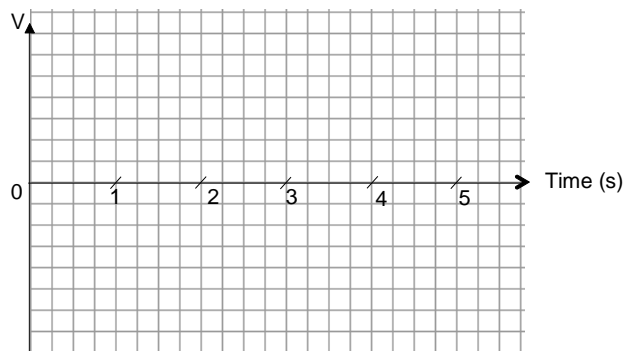
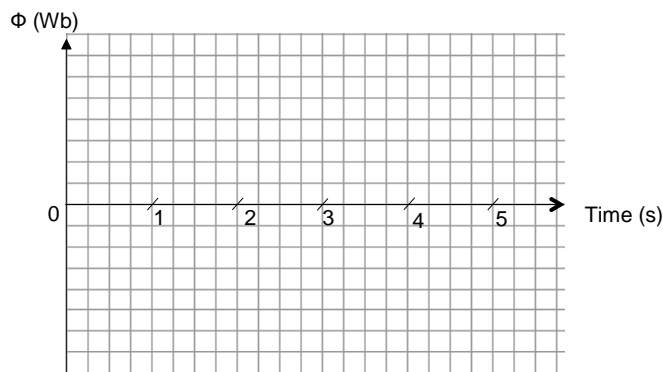
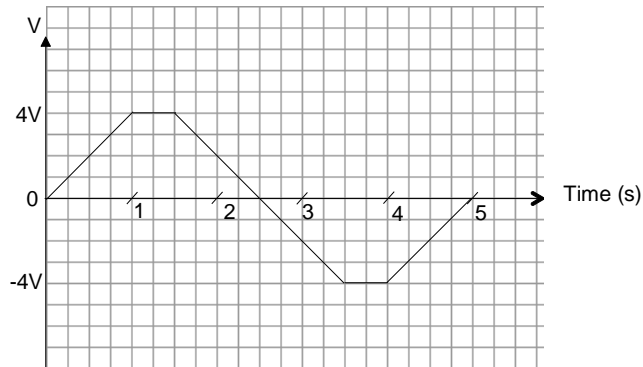

SECTION B – continued

Question 13 (7 marks)

A generator, operating a 5 kV AC RMS, delivers power to a distant school.

At a given point in time, the equipment at the school consumes 22.34 kW of power.

The transmission lines linking the generator and the school have a total resistance of 8Ω and are carrying 4.5 A RMS current. A transformer is located adjacent to the school.

The setup is shown below in **Figure 14**.

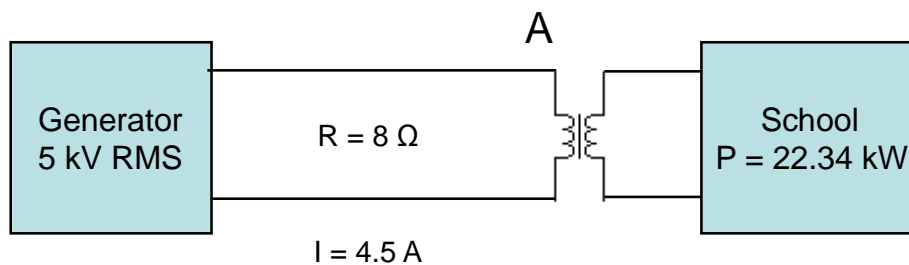

Figure 14

- a. Determine the power lost in the transmission lines. 2 marks

W

- b. Determine the voltage at the primary side of the transformer, labelled as Point A in Figure 14. 2 marks

V

SECTION B – Question 13 - continued
TURN OVER

PHYS EXAM

- c. Which of the following turns ratios would be most appropriate for the transformer (*Primary : Secondary*)? 3 marks

- A. 20 : 400
- B. 20 : 1
- C. 20 : 20000
- D. 20000 : 20

Justify your choice with a sample calculation.

Ratio:

Question 14 (6 marks)

A light wave enters an unknown media from air. While in the media it travels at a speed of $1.875 \times 10^8 \text{ m s}^{-1}$ and has a frequency of $5.455 \times 10^{14} \text{ Hz}$. It enters the media at an angle of 30° to the normal.

- a. What is the wavelength of the wave? 2 marks

m

SECTION B – Question 14 - continued

PHYS EXAM

b. What is the index of refraction of the material in which the wave is travelling?

2 marks

c. What is the angle refraction as the the light enters the media?

2 marks

SECTION B – continued
TURN OVER

Question 15 (5 marks)

Brian is investigating Young’s famous double-slit experiment.

Using a laser source to improve the clarity of the pattern, he recreates the setup and manages to achieve a similar light and dark pattern, as shown in **Figure 15**.

C represents a point equidistant from both sources.

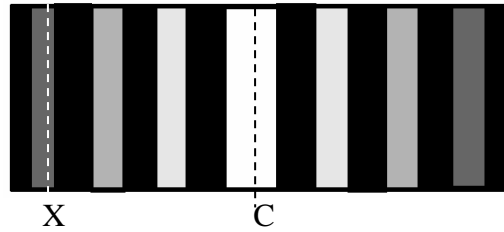

Figure 15

- a.** If the path difference for point X on Brian’s pattern is known to be 1.5×10^{-6} m, calculate the wavelength of the laser source. 2 marks

m

- b.** Explain why Young’s (and Brian’s) double-slit experiment supports the wave but not the particle model for light. 3 marks

SECTION B – continued

Question 16 (14 marks)

Students conducted a photo-electric experiment in which they used a light source and various filters to allow light of different frequencies to fall on the metal plate of a photo-electric cell. The maximum kinetic energy of any emitted photo-electrons was determined by measuring the voltage required, V_s (stopping voltage), to just stop them reaching the collector electrode. The apparatus is shown in **Figure 16**.

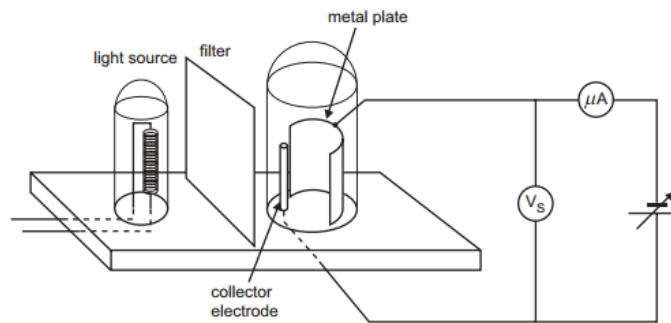

Figure 16

Figure 17 shows the stopping voltage, V_s , as a function of the frequency (f) of the light falling on the plate.

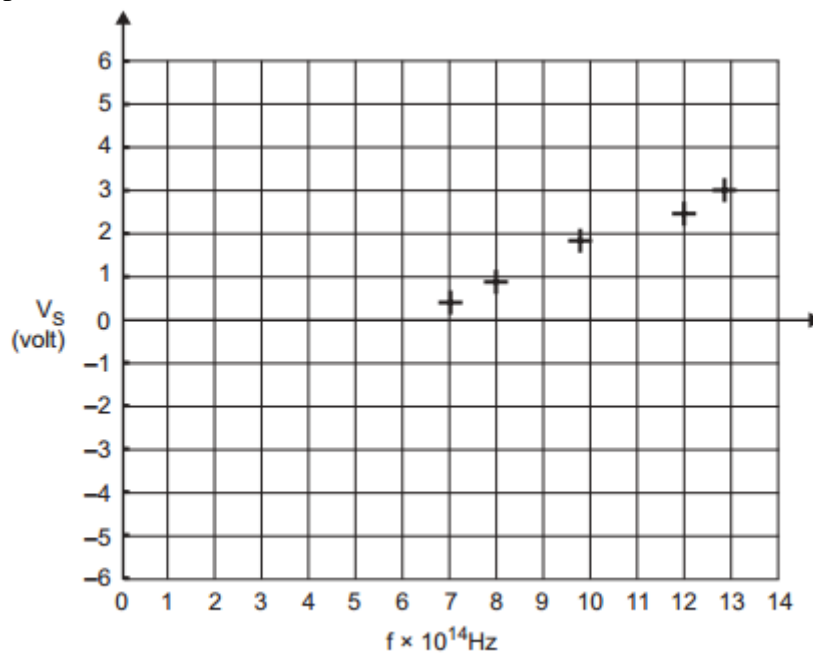

Figure 17

a. Write a suitable hypothesis for this experiment.

2 marks

**SECTION B – Question 16 - continued
TURN OVER**

b. Identify the controlled, independent and dependent variables in this experiment.

3 marks

Controlled:

Independent:

Dependent:

Table 1 shows the work functions for a series of metals.

Metal	Work function
selenium	1.90 eV
sodium	2.75 eV
copper	4.70 eV
gold	5.30 eV

Table 1

c. Use the information above to identify the metal surface used in the student's experiment.

2 marks

d. Use the results in Figure 17 to calculate the value for Planck's constant that the students would have obtained from the data in eVs. You must show your working.

3 marks

eV

SECTION B – Question 16 - continued

e. Calculate the percentage error within the result.

2 marks

%

f. Identify a systematic and random error that must be accounted for.

2 marks

Question 17 (4 marks)

Students are investigating diffraction patterns generated by x-rays and electrons directed through a fine mesh.

The pattern formed by electrons that have been accelerated by a pair of 400 V plates is very similar to that observed by a separate x-ray source.

a. Determine the wavelength of the electrons used in the experiment.

2 marks

m

SECTION B – Question 17 - continued
TURN OVER

- b. Determine the energy of a single photon of the x-ray source required for the matching diffraction patterns. 2 marks

eV

Question 18 (7 marks)

Figure 18 shows an energy level diagram for an element which can absorb and emit photons in its gaseous state.

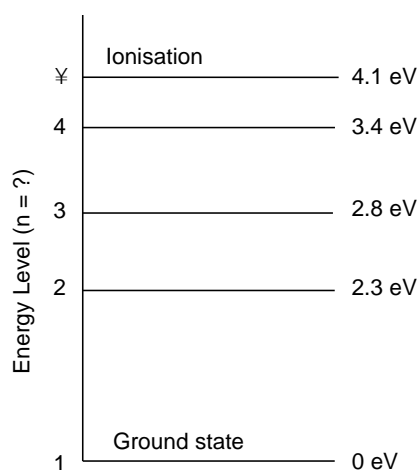

Figure 18

- a. Determine the wavelength of a photon required to send an electron from ground state to the excited state corresponding to $n = 4$. 1 mark

nm

SECTION B – Question 18 - continued

PHYS EXAM

b. Which of the following photon energies could be observed as the electron returns to ground state from $n = 4$? There may be more than one answer. 1 mark

- A.** 0.5 eV
- B.** 0.7 eV
- C.** 2.3 eV
- D.** 3.4 eV

c. Explain how the existence of electrons transitioning discrete energy levels supports both the wave and particle model for matter. 2 marks

d. Draw a diagram to show how an electron can be modelled in the state $n = 3$. 2 marks

END OF QUESTION AND ANSWER BOOK

Data Sheet

1	Velocity, acceleration	$v = \frac{\Delta x}{\Delta t} \quad a = \frac{\Delta v}{\Delta t}$
2	Equations for constant acceleration	$v = u + at$ $x = ut + \frac{1}{2}at^2$ $v^2 = u^2 + 2as$ $x = \frac{1}{2}(u + v)t$
3	Newton's second law	$F = ma$
4	Circular motion	$a = \frac{v^2}{r} = \frac{4\pi^2 r}{T^2}$
5	Hooke's law	$F = -kx$
6	Elastic potential energy	$\frac{1}{2}kx^2$
7	Gravitational potential energy near the surface of the earth	mgh
8	Kinetic energy	$\frac{1}{2}mv^2$
9	Lorentz factor	$\gamma = \frac{1}{\sqrt{1 - \frac{v^2}{c^2}}}$
10	Time dilation	$t = t_0\gamma$
11	Length contraction	$L = L_0 / \gamma$
12	Relativistic mass	$m = m_0\gamma$
13	Newton's law of universal gravitation	$F = \frac{GM_1M_2}{r^2}$
14	Gravitational field	$g = \frac{GM}{r^2}$
15	Transformer action	$\frac{V_1}{V_2} = \frac{N_1}{N_2}$
16	AC voltage and current	$V_{\text{RMS}} = \frac{1}{\sqrt{2}}V_{\text{peak}} \quad I_{\text{RMS}} = \frac{1}{\sqrt{2}}I_{\text{peak}}$
17	Voltage, power	$V = IR, \quad P = VI$
18	magnetic force	$F = I\ell B$

PHYS EXAM

19	electromagnetic induction	emf : $\varepsilon = -N \frac{\Delta\phi}{\Delta t}$ flux : $\phi = BA$
20	transmission losses	$V_{\text{drop}} = I_{\text{line}} R_{\text{line}}$ $P_{\text{loss}} = I_{\text{line}}^2 R_{\text{line}}$
21	Snell's Law	$n_1 \sin i = n_2 \sin r$
22	photoelectric effect	$E_{k \text{ max}} = hf - W$
23	photon energy	$E = hf$
24	photon momentum	$p = \frac{h}{\lambda}$
25	de Broglie wavelength	$\lambda = \frac{h}{p}$
26	Planck's constant	$h = 6.63 \times 10^{-34} \text{ J s}$ $h = 4.14 \times 10^{-15} \text{ eV s}$
27	Universal gravitational constant	$G = 6.67 \times 10^{-11} \text{ N m}^2 \text{ kg}^{-2}$
28	Mass of Earth	$M_E = 5.98 \times 10^{24} \text{ kg}$
29	Radius of Earth	$R_E = 6.37 \times 10^6 \text{ m}$
30	Mass of the electron	$m_e = 9.1 \times 10^{-31} \text{ kg}$
31	Charge on the electron	$q = -1.6 \times 10^{-19} \text{ C}$
32	Speed of light	$c = 3.0 \times 10^8 \text{ ms}^{-1}$
33	energy transformations for electrons in an electron gun (<100 keV)	$\frac{1}{2} m v^2 = eV$
34	radius of electron beam	$r = \frac{p}{qB}$
35	force applied to an electron beam	$F = qvB$
36	electric field between charged plates	$E = \frac{V}{d}$

Prefix/Units

$$p = \text{pico} = 10^{-12}$$

$$n = \text{nano} = 10^{-9}$$

$$\mu = \text{micro} = 10^{-6}$$

$$m = \text{milli} = 10^{-3}$$

$$k = \text{kilo} = 10^3$$

$$M = \text{mega} = 10^6$$

$$G = \text{giga} = 10^9$$

$$t = \text{tonne} = 10^3 \text{ kg}$$

SECTION A MULTIPLE CHOICE ANSWER SHEET

Answers – Circle ONE of A-D for each of the 11 multiple choice questions.

Question	Answer			
1	A	B	C	D
2	A	B	C	D
3	A	B	C	D
4	A	B	C	D
5	A	B	C	D
6	A	B	C	D
7	A	B	C	D
8	A	B	C	D
9	A	B	C	D
10	A	B	C	D
11	A	B	C	D
12	A	B	C	D
13	A	B	C	D
14	A	B	C	D
15	A	B	C	D
16	A	B	C	D
17	A	B	C	D
18	A	B	C	D
19	A	B	C	D
20	A	B	C	D