



**SECTION A – Multiple Choice Questions**

**Instructions for Section A**

Answer **all** questions in pencil on the answer sheet provided for multiple choice questions.

Choose the response that is **correct** and that **best answers** the question

A correct answer **scores** 1; an incorrect answer scores 0

Marks will not be deducted for incorrect answers

Unless indicated the diagrams in this book are **not** drawn to scale

Take the value of  $g$  to be  $9.8 \text{ ms}^{-2}$

**Question 1**

Figure 1 represents the electric field around a negative charge.

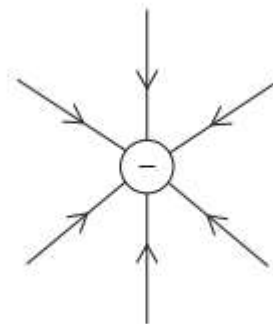

**Figure 1**

If the magnitude of the charge were doubled, which diagram would best represent the new electric field?

**A**

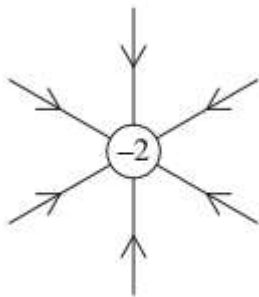

**B**

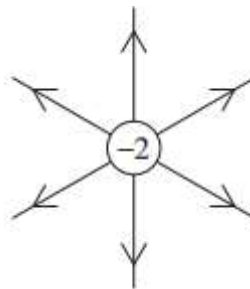

**C**

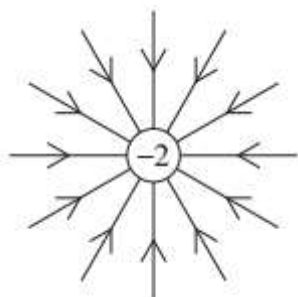

**D**

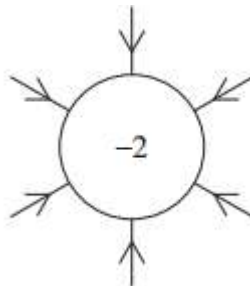

**SECTION A – continued**

**Question 2**

A positive charge moving with a constant velocity  $v$  enters a region of a uniform magnetic field pointing out the page as shown in Figure 2.

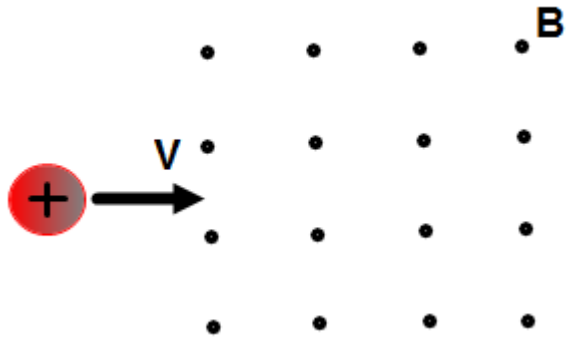

What is the direction of the magnetic force on the charge?

- A. Left.
- B. Right.
- C. To the bottom of the page.
- D. To the top of the page.

**Question 3**

Two masses have a gravitational force of 12 N between them. If the distance between the masses is doubled, what would be the new gravitational force between them?

- A. 3 N
- B. 6 N
- C. 12 N
- D. 24 N

**SECTION A – continued  
TURN OVER**

**Question 4**

A ball is thrown straight up from point A, reaches a maximum height at point B, and then falls back to point C, as illustrated in Figure 3



**Figure 3**

Which of the following is true about the ball's velocity and acceleration the highest point B?

- A. Its velocity and acceleration are both zero
- B. Its velocity is up and non-zero constant and acceleration is zero
- C. Its velocity is down and non-zero constant and acceleration is zero
- D. Its velocity is zero and acceleration is down and non-zero constant

**Question 5**

Consider the following four statements

- I. The speed of light is absolute
- II. There is no absolute frame of reference or absolute rest
- III. Absolute rest exists: there is somewhere in the Universe that can be considered stationary
- IV. The laws of physics are the same for all objects, at rest or in motion.

With regard to statements I to IV, which of the following is correct?

- A. **I, II & IV** are Einstein's postulates for special relativity; **III** is a Galilean concept.
- B. **I & IV** are Einstein's postulates for special relativity; **II** is a Galilean concept and **III** is a pre-Galilean idea
- C. **III** is Einstein's postulate for special relativity; **I, II & IV** are Galilean concept.
- D. **I** is Einstein's postulate for special relativity; **II, III & IV** are all Galilean concepts.

**SECTION A – continued**

**Question 6**

Relativity of simultaneity can be illustrated by the following example:

*A light in the centre of a carriage is switched on as the carriage passes a platform.  
An observer on the train will see the light strike the ends of the carriage simultaneously, while  
an observer on the platform will see the light hit the rear of the carriage first.*

The reason for this difference is best described by which of the following statements?

- A. Light travels faster outside the train
- B. The platform observer experiences length contraction
- C. The carriage contracts in length, with the rear half becoming shorter
- D. The light has further to travel to the front of the carriage according to the observer on the platform.

**Question 7**

In the motor shown in Figure 4, the rotor spins clockwise, as viewed from point P, when connected to a DC supply.

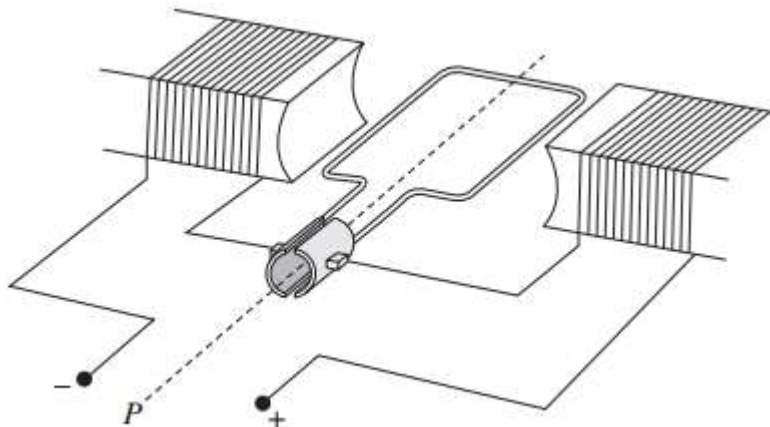

**Figure 4**

What happens when the motor is connected to an AC supply?

- A. There is no movement of the rotor.
- B. The rotor produces clockwise movement only.
- C. The rotor vibrates at the frequency of the AC supply.
- D. The rotor continuously turns half a rotation clockwise, then half a rotation anticlockwise.

**SECTION A – continued  
TURN OVER**

**Question 8**

A square loop of wire lies in the plane of the page. A decreasing magnetic field is directed into the page. The induced current in the loop is?

- A. Anti-clockwise.
- B. Clockwise.
- C. Zero.
- D. Depends upon whether or not B is decreasing at a constant rate.

*The following information refers to Questions 9 and 10*

Consider the output displayed on two CROs, as shown in Figure 5

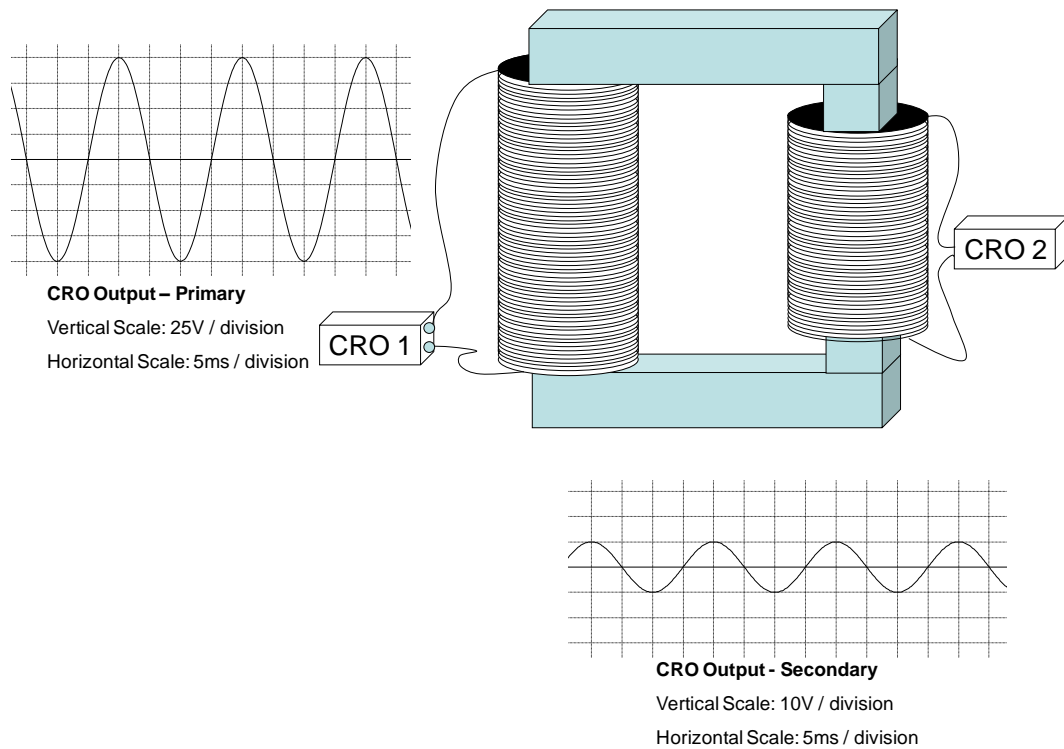

**Figure 5**

**Question 9**

Which of the following is closest to the RMS voltage at the primary side of the transformer?

- A. 2.8 V
- B. 71 V
- C. 100 V
- D. 141 V

**SECTION A – continued**

**Question 10**

Which of the following best matches the transformer turns ratio (*primary : secondary*)

- A. 10:1
- B. 1:10
- C. 4:1
- D. 1:4

**Question 11**

An investigation is designed to determine the size of the generated current when the strength of a magnet is varied. Which is the independent variable for this investigation?

- A. Speed of the magnet
- B. Strength of the magnet
- C. Size of the generated current
- D. Distance between the coil and the magnet

**Question 12**

Students performed an investigation to determine the initial velocity of a projectile. Which row correctly identifies a hazard of this investigation and a related precaution?

<i>Hazard</i>	<i>Safety precaution</i>
A. Flying projectile	Wearing safety glasses
B. Range of projectile	Measuring the range with a tape measure
C. Enclosed shoes	Wearing sandals
D. Safety glasses	Flying projectile

**Question 13**

Which of the following statements provides the best explanation for the phenomena of resonance that is occurring in the tube?

- A. A longitudinal wave reflects and undergoes destructive interference, leaving a standing wave which can be heard at the resonant frequency.
- B. The sides of the tube amplify the sound wave as it reflects off them, increasing in amplitude. At a resonant frequency, these transverse reflections are maximised.
- C. A standing wave enters the tube and continuously reflects, increasing in amplitude.
- D. A sound wave enters the tube and reflects from the open end. At a resonant frequency, the incident and reflected waves interfere constructively, generating a standing wave with a larger amplitude.

**SECTION A – continued  
TURN OVER**

**Question 14**

A ray of light in air is incident on an air-to-glass boundary at an angle of 30 degrees with the normal. If the index of refraction of the glass is 1.65, what is the angle of the refracted ray within the glass with respect to the normal?

- A. 56 degrees
- B. 46 degrees
- C. 30 degrees
- D. 18 degrees

**Question 15**

In the photoelectric effect experiment, the frequency of the light is increased while keeping the intensity of the light constant. What effect does this have?

- A. More electrons will be ejected with the same kinetic energy
- B. More electrons will be ejected with the an increased kinetic energy
- C. The same number of electrons will be ejected with the same amount of kinetic energy
- D. The same number of electrons will be ejected with an increased kinetic energy

**Question 16**

What happens to the de Broglie wavelength of an electron if its momentum is doubled?

- A. Decreases by a factor of 2
- B. Decreases by a factor of 4
- C. Increases by a factor of 2
- D. Increases by a factor of 4

**Question 17**

Which of the following reasons best illustrates why synchrotron radiation is preferred to laser and x-ray tube radiation?

- A. Synchrotron radiation has high divergence, which makes it easier to direct
- B. Synchrotron radiation is less intense, so it can travel further
- C. Synchrotron radiation has a very long wavelength, so it diffracts readily
- D. Synchrotron radiation is tuneable, so users are able to choose from a broad range of wavelengths.

**SECTION A – continued**



**Question 18**

Some of the energy levels of the hydrogen atom are shown in Figure 6

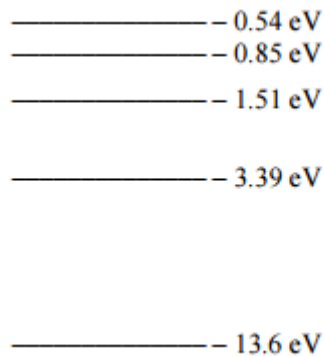

**Figure 6**

Electrons are excited to the 0.85 eV level. How many different photon frequencies will be observed in the emission spectrum of hydrogen?

- A. 3
- B. 4
- C. 5
- D. 6

**Question 19**

When electrons of suitable energy travel through a thin layer of graphite, a pattern of concentric circles is produced on a screen as shown in Figure 7

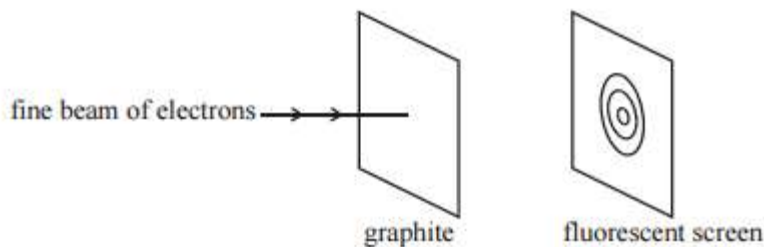

**Figure 7**

The production of this pattern is evidence for

- A. The wave nature of the electron.
- B. The nuclear model of the atom.
- C. The particle nature of the electron.
- D. The existence of X-rays.

**SECTION A – continued  
TURN OVER**

**Question 20**

Which of the following correctly lists electromagnetic waves in order from longest to shortest wavelength?

- A. gamma rays, ultraviolet, infrared, microwaves
- B. microwaves, ultraviolet, visible light, gamma rays
- C. radio waves, infrared, gamma rays, ultraviolet

**END OF SECTION A**

**SECTION B – Short Answer**

**Instructions for Section B**

Answer **all** questions in the spaces provided. Write using blue or black pen  
 Where an answer box is provided, write your full answer in the box.  
 If an answer box has a unit provided in it, give your answer in that unit.  
 In questions where more than one mark is available, appropriate working **must** be shown.  
 Unless indicated the diagrams in this book are **not** drawn to scale  
 Take the value of  $g$  to be  $9.8 \text{ ms}^{-2}$

**Question 1** (6 marks)

Figure 1 shows a pair of flat, wide metal plates. They are parallel and connected to a constant 2000 V supply.

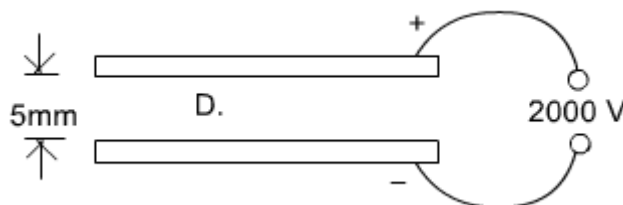

**Figure 1**

- a.** What is the electric field between the plates? 2 marks

---



---



---

$\text{Vm}^{-1}$

- b.** A drop of oil, between the plates carries a charge of 10 electrons, what is the force on the drop? 2 marks

---



---



---

N

**SECTION B – Question 1 - continued**  
**TURN OVER**

PHYS EXAM

- c. If the drop moves a distance of 2.5 mm towards the positive plate, how much electrical energy is transferred? 2 marks

---

---

---

<b>J</b>
----------

**SECTION B** – continued

**Question 2** (7 marks)

The luxurious Anderson Space Station is orbiting the earth, as depicted in Figure 2.

**Data:**

- Mass of Earth:  $M_E = 5.98 \times 10^{24}$  kg
- Radius of Earth:  $R_E = 6.37 \times 10^6$  m
- Mass of Anderson: 3.6 tonnes
- Period of orbit: 120 mins

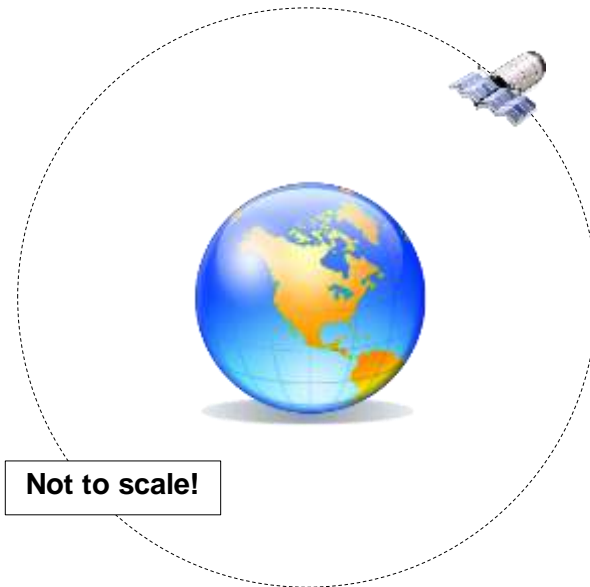

**Figure 2**

a. Determine the **altitude** of the Anderson Space station above the Earth's surface.

2 marks

---

---

---

<b>m</b>
----------

**SECTION B – Question 2 - continued**  
**TURN OVER**

- b. Calculate the value of the gravitational field strength experienced by Anderson whilst in orbit. 2 marks

---

---

---

$\text{Nkg}^{-1}$
-------------------

Media reports claim that the brave astronauts aboard Anderson “experience life in weightless conditions”

- c. Are the astronauts actually **weightless**? Explain their actual experience of weight whilst in orbit. 3 marks

---

---

---

---

**Question 3** (5 marks)

Figure 3a shows a single loop of wire powered by a battery.

- a. Use appropriate symbols to indicate the direction of the magnetic field. Be sure to clearly indicate the field both inside **and** outside of the loop. 3 marks

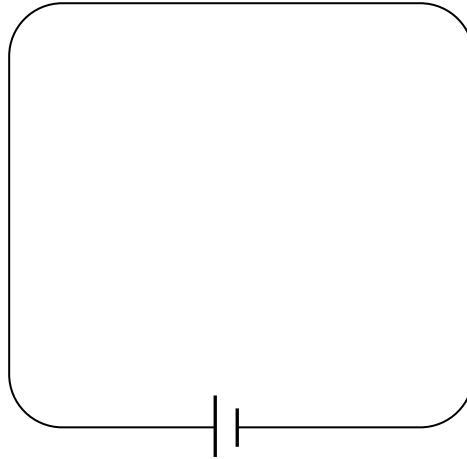

**Figure 3a**

Jacky places a section of current carrying wire adjacent to a loop as shown in Figure 3b. The current through the new section is 2.5 A and it is 4 cm in length. The magnitude of the field in the region of the wire is  $2.0 \times 10^{-2}$  T.

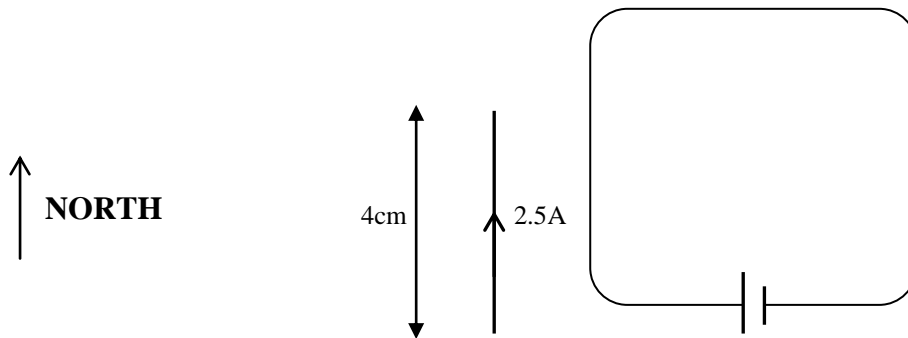

**Figure 3b**

- b. Determine the magnitude and direction of the force acting on the wire. 2 marks

---



---



---

N
---

Direction:
------------

**SECTION B – continued  
TURN OVER**

**Question 4** (4 marks)

Graham the locomotive accelerates from rest with three carriages attached, as depicted in Figure 4.

**Data:**

- Locomotive mass is 500 kg.
- Each carriage has a mass of 200 kg.
- The locomotive uses a driving force of 4000 N to pull the carriages.
- Friction forces of 30 N per 100 N of weight force act to resist the motion on the locomotive and each carriage.

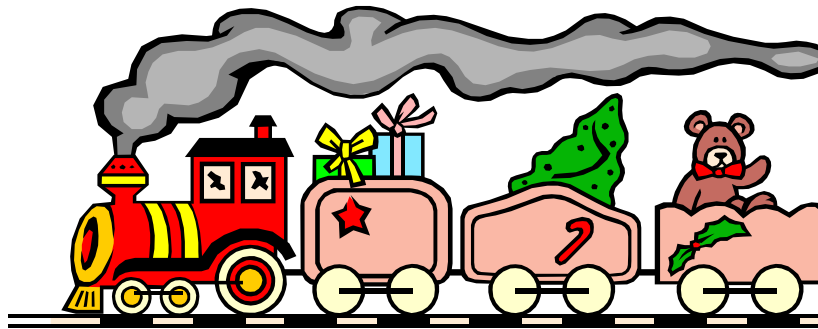

**Figure 4**

a. Calculate the overall acceleration of the train.

2 marks

---

---

---

$\text{ms}^{-2}$
------------------

b. Calculate the tension in the coupling between the locomotive and the first carriage.

2 marks

---

---

---

N
---

**SECTION B** – continued



**Question 5** (5 marks)

Kate the bus driver is travelling at a constant speed around a banked track as depicted in Figure 5 (Note: the bus is coming **towards** the observer).

**Data:**

- Mass of bus is 1200 kg
- Radius of track is 200 m
- Angle of bank is  $35^\circ$  to the horizontal

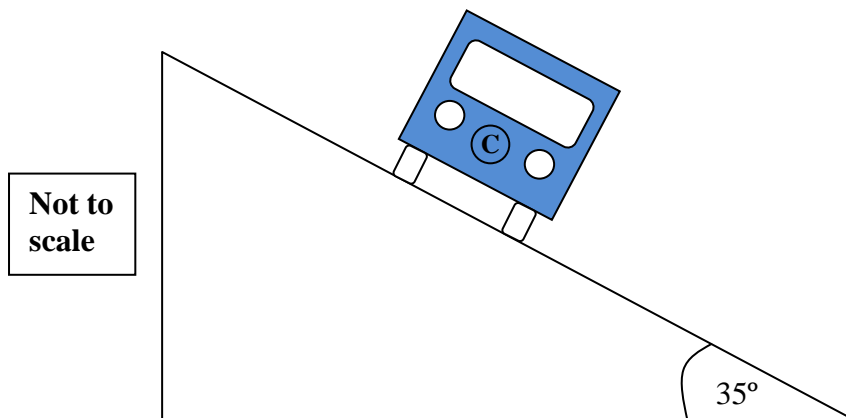

**Figure 5**

- a. Draw and label the key forces acting on the bus as it travels around the track. Assume friction is acting **up** the slope of the track for this question. Assume centre of mass through **C** on Figure 2. Label the reaction force as one combined force, **N**. 2 marks
- b. Calculate the **maximum speed** that could be achieved **without any friction** acting **down** the slope. 3 marks

---



---



---



---

$\text{ms}^{-1}$

**SECTION B – continued  
TURN OVER**

**Question 6** (5 marks)

Konrad decides to attempt a daredevil stunt aboard his trusty motorcycle. With a ramp aiding his takeoff and landing, he just clears a 75 m long pool of ice cold water. The jump is completed in exactly **3.5 seconds** and is depicted in Figure 6.

Ignore air resistance in your calculation.

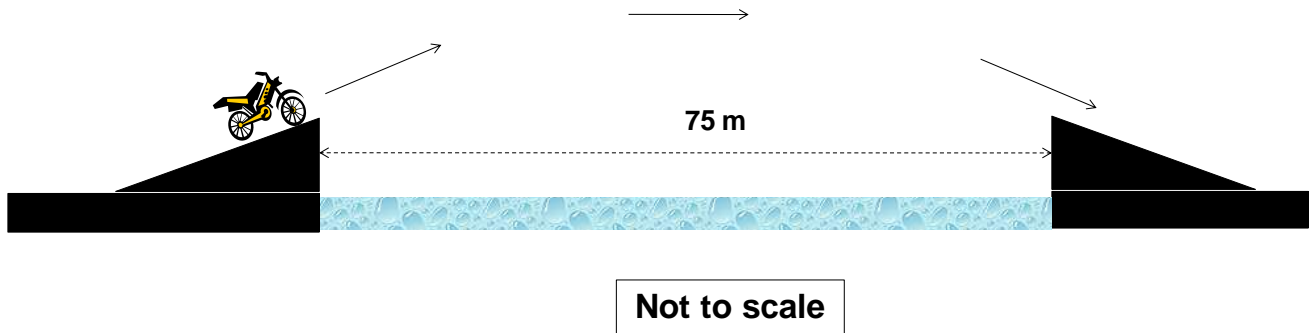

**Figure 6**

- a.** Calculate the maximum height reached by Konrad **above the top of the ramp**.

2 marks

---

---

---

<b>m</b>
----------

- b.** Calculate the angle of elevation of Konrad as he leaves the ramp. Give your answer to the nearest degree.

3 marks

---

---

---

---

<b>degrees</b>
----------------

**SECTION B** – continued

**Question 7** (9 marks)

In an unfortunate incident on a frozen lake, a small car travelling west collides with a US Army Hummer. The Hummer is initially stationary and during the collision both vehicles lock together and then continue to move west at  $4.5 \text{ ms}^{-1}$

**Data:**

- Mass of car is 700 kg
- Ignore friction on the icy surface
- Duration of the collision is 0.2 sec

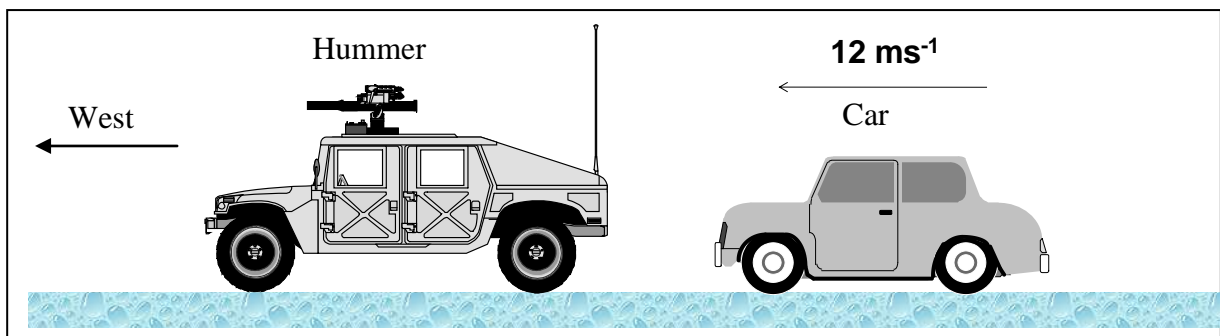

**Figure 7**

- a. Calculate the total momentum of the system before the collision. (magnitude and direction) 2 marks

---



---



---

$\text{kgms}^{-1}$	Direction:
--------------------	------------

- b. Calculate the mass of the Hummer. 2 marks

---



---



---

$\text{kg}$
-------------

**SECTION B – Question 7 - continued**  
**TURN OVER**

- c. Calculate the impulse of the Hummer on the car during the collision. 2 marks

---

---

---

Ns	Direction:
----	------------

- d. State whether the collision is **elastic** or **inelastic**. Use a calculation to justify your response. 3 marks

---

---

---

---

---

**SECTION B** – continued

**Question 8** (6 marks)

Isabel drops a 2 kg medicine ball, from rest, onto a spring as shown in Figure 8.

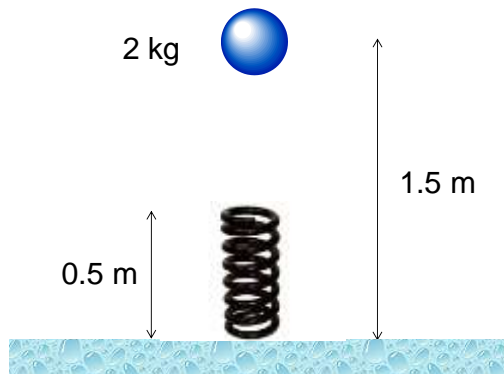

**Figure 8**

- a.** Calculate the speed of the medicine ball just before it reaches the spring. 2 marks

---

---

---

$\text{ms}^{-1}$
------------------

The ball compresses the spring to a height of 0.3 m, at which point it is momentarily stationary.

- b.** Calculate the value of **k**, the spring constant. 2 marks

---

---

---

$\text{Nm}^{-1}$
------------------

**SECTION B – Question 8 - continued**  
**TURN OVER**

PHYS EXAM

Next, the spring recoils and the ball rebounds to a height of 1.3 m.

- c. Calculate the amount of energy lost in the series of transformations, starting from when Isabel drops the ball **AND** explain what form these losses would take. 2 marks

---

---

---

---

---

<b>J</b>
----------

**SECTION B – continued**

**Question 9** (4 marks)

Gennady is test driving his new van through a series of crests and dips to establish whether he will be able to use it in the next Dakar Rally. Figure 9 shows Gennady as he negotiates the bottom of a dip and Figure 10 sees him at the top of a crest.

**Data:**

- Mass of van and driver: 1.3 tonnes
- Radius of dip: 200 m
- Radius of crest: 150 m
- Assume both crest and dip are parts of vertical circles

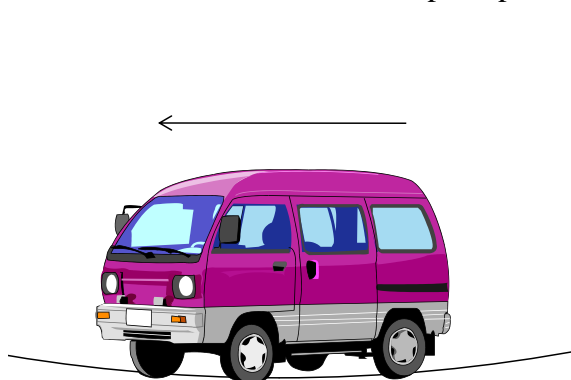

**Figure 9**

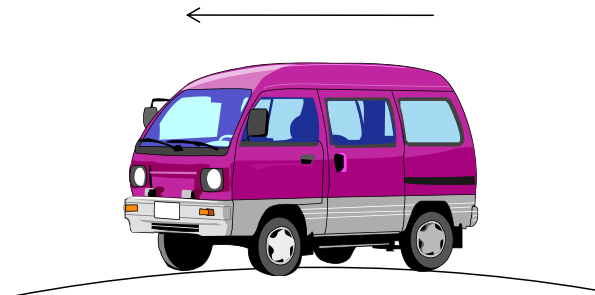

**Figure 10**

- a. Calculate the apparent weight of the van as it reaches the bottom of the dip (Figure 9), with a speed of  $25 \text{ ms}^{-1}$ . 2 marks

---



---



---

N
---

- b. Calculate the speed required for an apparent weight of 0 N as Gennady reaches the top of the crest (Figure 10). 2 marks

---



---



---

$\text{ms}^{-1}$
------------------

**SECTION B – continued  
TURN OVER**

**Question 10** (10 marks)

A spaceship passes an observer on Earth at a speed of  $0.85c$ . The observer measures its length to be 250 m.

- a. Calculate the length of the spaceship as measured by the captain on board the ship. 2 marks

---

---

---

<b>m</b>
----------

- b. The spaceship from Earth is heading to a star which is known to be 4.5 light years away. How long in years would it take the spaceship to reach the star as measured by the observer on Earth? 2 marks

---

---

---

<b>years</b>
--------------

- c. How long in years would it take the spaceship to reach the star as measured by the occupants of the spaceship? 2 marks

---

---

---

<b>years</b>
--------------

**SECTION B – Question 10 - continued**



- d.** What is the distance travelled, according to the occupants of the spaceship?  
2 marks

---

---

---

**km**

- e.** Before take-off, the captain of the spaceship had the craft weighed on earth. Its mass was recorded at 11 tonnes. What would be the mass of the craft as measured by an observer on earth, in tonnes?  
2 marks

---

---

---

**tonnes**

**SECTION B – continued**  
**TURN OVER**

**Question 11** (13 marks)

Winston has constructed a DC motor as shown in Figure 11a. He wants it to rotate **clockwise** as shown.

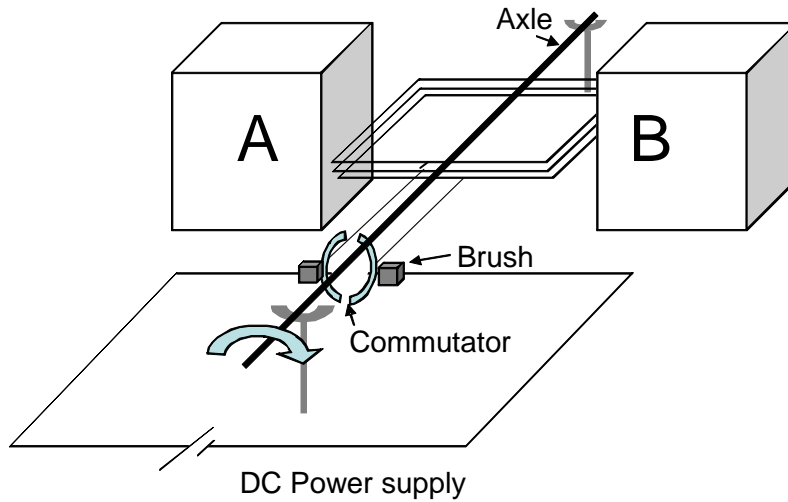

**Figure 11a**

- a. If the current flows clockwise around the coil (as viewed from above), determine which of the magnets A and B should be the North and South poles. 2 marks

<b>A:</b>	<b>B:</b>
-----------	-----------

- b. Explain why a **commutator** is essential for the effective operation of a DC motor. 3 marks

---

---

---

---

---

**SECTION B – Question 11 - continued**

Dean now rearranges the setup **by** removing the battery and replacing it with a CRO. He measures the coil to be 5cm x 5cm and measures the magnetic field as  $3.0 \times 10^{-2}$  T. There are 20 turns in the coil. The resulting generator is shown in Figure 14b.

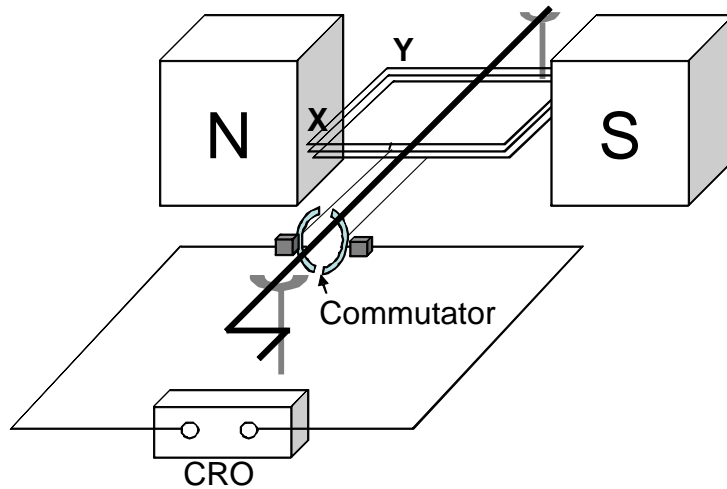

**Figure 11b**

- c. Calculate the magnitude of the flux through the coil while positioned as shown in Figure 11b. 2 marks

---



---



---

<b>Wb</b>
-----------

Dean now rotates the coil  $90^\circ$  in an anti-clockwise direction, taking 0.5 sec.

- d. Calculate the magnitude of the average emf generated in the coil as it rotates through  $90^\circ$  in an anti-clockwise direction. Give your answer in millivolts. 3 marks

---



---



---

<b>mV</b>
-----------

**SECTION B – Question 11 - continued**  
**TURN OVER**

- e. Explain, using appropriate principles and referring to Points **X** and **Y** on Figure 11b, which direction the current will initially flow as Dean rotates the coil  $90^\circ$  **anti-clockwise**. 3 marks

---

---

---

---

**Question 12** (3 marks)

Figure 12 shows Justin’s solenoid, which is connected to a DC power supply. When looking into the solenoid from point **A**, the current is moving anticlockwise as shown. A single copper ring is positioned between **A** and the solenoid.

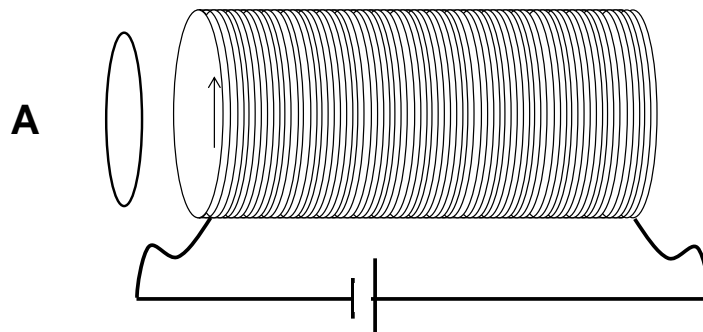

**Figure 12**

Determine the direction of the induced current in the ring (as viewed from **A**) if the power supply is disconnected. Explain your answer using Lenz’s law.

---

---

---

---

**SECTION B** – continued

**Question 13** (9 marks)

A power station generates an AC voltage of 50 Hz with a magnitude of 15 kV RMS

- a. Calculate the peak voltage of the generator. 2 marks

---



---



---

**kV**

The generator is now connected via a basic transmission system to a small town called Knox. On one ordinary Wednesday, the Knox townsfolk demand a total of 20 kA. A simplified diagram of the system is shown in Figure 15b.

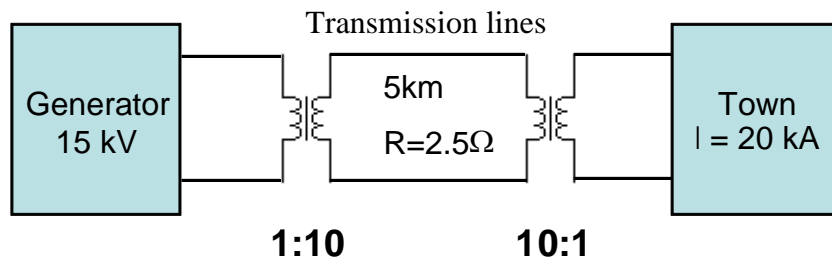

**Figure 15b**

- b. Determine the power loss in **the transmission lines**, which have a **total** resistance of 2.5 Ω. 3 marks

---



---



---

**MW**

c. Determine the voltage available at the town of Knox.

2 marks

---

---

---

<b>kV</b>
-----------

d. Explain why the step-up transformer at the generator site would **not** function correctly if the generator was producing smooth DC instead of AC. 2 marks

---

---

---

---

---

---

---

**SECTION B** – continued

**Question 14** (4 marks)

Light can be considered to have wavelike characteristics in certain circumstances.

**a.** What is a transverse wave?

2 marks

---

---

---

---

**b.** Explain how you would prove that light is a transverse wave.

2 marks

---

---

---

---

---

---

---

**SECTION B – continued**  
**TURN OVER**

**Question 15** (4 marks)

Figure 16 shows an interference pattern generated by a laser directed at a pair of narrow slits, similar to Young's experiment. The light used has a wavelength of 560 nm.

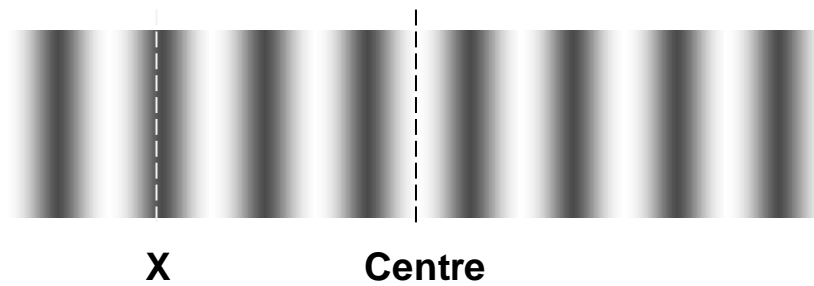

**Figure 16**

- a. Determine the path difference to **Point X**. Give your answer in nanometres. 2 marks

---

---

---

nm
----

- b. Describe the effect of **increasing** the gap between the two slits. 2 marks

---

---

---

---

---

**SECTION B** – continued



**Question 16** (12 marks)

Nirav is undertaking an experiment to observe and measure the photoelectric effect. He constructs a photocell and circuit, which is shown in simplified form below in Figure 17.

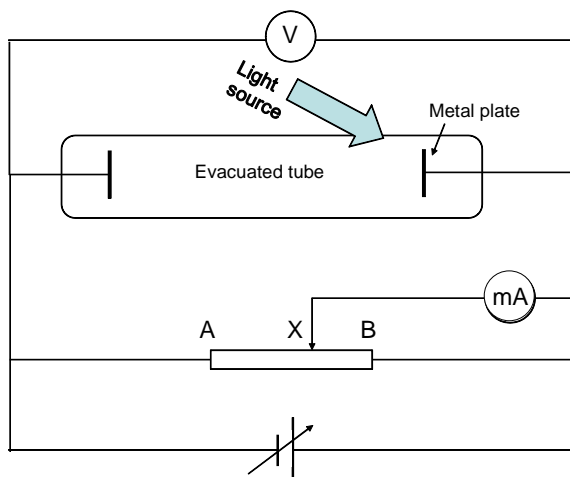

**Figure 17**

When using a light source of 450 nm, Nirav records a stopping voltage of 0.6 V

- a. Identify the independent and dependent variables within Nirav’s experiment.

2 marks

---



---



---

<b>Independent</b>	<b>Dependent</b>
--------------------	------------------

- b. For this particular experiment, identify one important **controlled** variable and indicate why this variable should be controlled.

2 marks

---



---



---

**SECTION B – Question 16 - continued**  
**TURN OVER**

- c. Determine the threshold frequency of the metal in the photocell. 3 marks  
 ( $h = 4.14 \times 10^{-15} \text{ eVs} = 6.63 \times 10^{-34} \text{ Js}$ )

---



---



---

<b>Hz</b>
-----------

Using light of a particular frequency, Nirav collects a series of data points and constructs a graph of stopping voltage vs. photocurrent. This is shown below in Figure 17c.

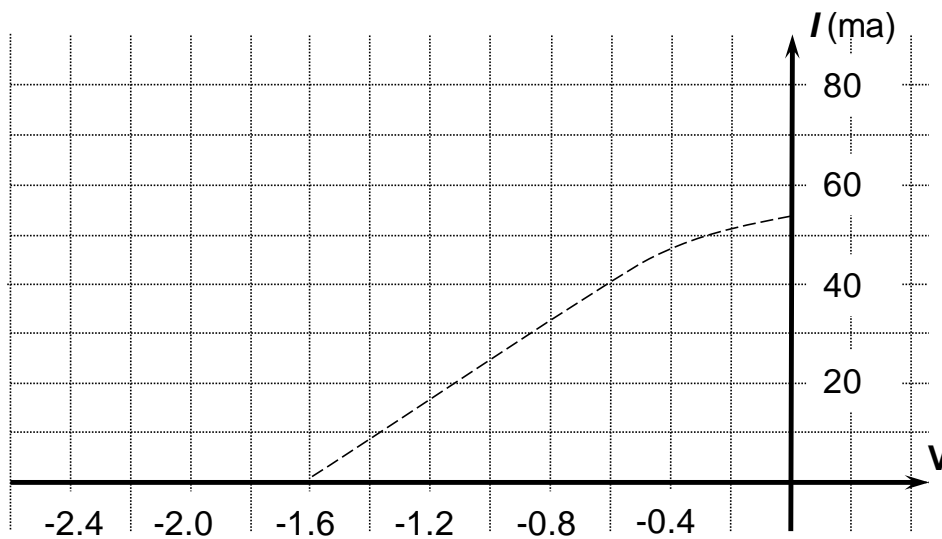

Figure 17c

Nirav changes the light source to a brighter, but lower frequency source.

- d. Sketch the expected I-V characteristic curve on Figure 18c. 2 marks

- e. It is said that the photoelectric effect “provides evidence for the particle-like nature of light” but also that “the wave model of light cannot account for the experimental photoelectric effect results”.

Explain how these statements can be true, providing examples to justify your explanation. 3 marks

---

---

---

---

---

---

---

**Question 17** (4 marks)

Vinay is discussing two similar diffraction patterns. One has been generated by high speed electrons fired through a crystal, the other by X-Rays also directed towards the same crystal. Figure 18 shows the two patterns aligned, demonstrating the matching node and antinode points.



**Figure 18**

- a. If the energy of the X-Rays is known to be 451 keV, determine their wavelength.  
( $h = 4.14 \times 10^{-15} \text{ eVs} = 6.63 \times 10^{-34} \text{ Js}$ ) 2 marks

---

---

---

<b>m</b>
----------

- b.** Calculate the momentum of one electron in the experiment.  
( $h = 4.14 \times 10^{-15} \text{ eVs} = 6.63 \times 10^{-34} \text{ Js}$ )

2 marks

---

---

---

$\text{kgms}^{-1}$
--------------------

**END OF SECTION B**

**END OF QUESTION AND ANSWER BOOK**

**Data Sheet**

1	Velocity, acceleration	$v = \frac{\Delta x}{\Delta t} \quad a = \frac{\Delta v}{\Delta t}$
2	Equations for constant acceleration	$v = u + at$ $x = ut + \frac{1}{2}at^2$ $v^2 = u^2 + 2as$ $x = \frac{1}{2}(u + v)t$
3	Newton's second law	$F = ma$
4	Circular motion	$a = \frac{v^2}{r} = \frac{4\pi^2 r}{T^2}$
5	Hooke's law	$F = -kx$
6	Elastic potential energy	$\frac{1}{2}kx^2$
7	Gravitational potential energy near the surface of the earth	$mgh$
8	Kinetic energy	$\frac{1}{2}mv^2$
9	Lorentz factor	$\gamma = \frac{1}{\sqrt{1 - \frac{v^2}{c^2}}}$
10	Time dilation	$t = t_0\gamma$
11	Length contraction	$L = L_0 / \gamma$
12	Relativistic mass	$m = m_0\gamma$
13	Newton's law of universal gravitation	$F = \frac{GM_1M_2}{r^2}$
14	Gravitational field	$g = \frac{GM}{r^2}$
15	Transformer action	$\frac{V_1}{V_2} = \frac{N_1}{N_2}$
16	AC voltage and current	$V_{\text{RMS}} = \frac{1}{\sqrt{2}}V_{\text{peak}} \quad I_{\text{RMS}} = \frac{1}{\sqrt{2}}I_{\text{peak}}$
17	Voltage, power	$V = IR, \quad P = VI$
18	magnetic force	$F = I\ell B$

19	electromagnetic induction	emf : $\varepsilon = -N \frac{\Delta\phi}{\Delta t}$ flux : $\phi = BA$
20	transmission losses	$V_{\text{drop}} = I_{\text{line}} R_{\text{line}}$ $P_{\text{loss}} = I_{\text{line}}^2 R_{\text{line}}$
21	Snell's Law	$n_1 \sin i = n_2 \sin r$
22	photoelectric effect	$E_{k \text{ max}} = hf - W$
23	photon energy	$E = hf$
24	photon momentum	$p = \frac{h}{\lambda}$
25	de Broglie wavelength	$\lambda = \frac{h}{p}$
26	Planck's constant	$h = 6.63 \times 10^{-34} \text{ J s}$ $h = 4.14 \times 10^{-15} \text{ eV s}$
27	Universal gravitational constant	$G = 6.67 \times 10^{-11} \text{ N m}^2 \text{ kg}^{-2}$
28	Mass of Earth	$M_E = 5.98 \times 10^{24} \text{ kg}$
29	Radius of Earth	$R_E = 6.37 \times 10^6 \text{ m}$
30	Mass of the electron	$m_e = 9.1 \times 10^{-31} \text{ kg}$
31	Charge on the electron	$q = -1.6 \times 10^{-19} \text{ C}$
32	Speed of light	$c = 3.0 \times 10^8 \text{ ms}^{-1}$
33	energy transformations for electrons in an electron gun (<100 keV)	$\frac{1}{2} mv^2 = eV$
34	radius of electron beam	$r = \frac{p}{qB}$
35	force applied to an electron beam	$F = qvB$
36	electric field between charged plates	$E = \frac{V}{d}$

**Prefix/Units**

$$p = \text{pico} = 10^{-12}$$

$$n = \text{nano} = 10^{-9}$$

$$\mu = \text{micro} = 10^{-6}$$

$$m = \text{milli} = 10^{-3}$$

$$k = \text{kilo} = 10^3$$

$$M = \text{mega} = 10^6$$

$$G = \text{giga} = 10^9$$

$$t = \text{tonne} = 10^3 \text{ kg}$$

**SECTION A MULTIPLE CHOICE ANSWER SHEET****Answers – Circle ONE of A-D for each of the 11 multiple choice questions.**

<b>Question</b>	<b>Answer</b>			
<b>1</b>	<b>A</b>	<b>B</b>	<b>C</b>	<b>D</b>
<b>2</b>	<b>A</b>	<b>B</b>	<b>C</b>	<b>D</b>
<b>3</b>	<b>A</b>	<b>B</b>	<b>C</b>	<b>D</b>
<b>4</b>	<b>A</b>	<b>B</b>	<b>C</b>	<b>D</b>
<b>5</b>	<b>A</b>	<b>B</b>	<b>C</b>	<b>D</b>
<b>6</b>	<b>A</b>	<b>B</b>	<b>C</b>	<b>D</b>
<b>7</b>	<b>A</b>	<b>B</b>	<b>C</b>	<b>D</b>
<b>8</b>	<b>A</b>	<b>B</b>	<b>C</b>	<b>D</b>
<b>9</b>	<b>A</b>	<b>B</b>	<b>C</b>	<b>D</b>
<b>10</b>	<b>A</b>	<b>B</b>	<b>C</b>	<b>D</b>
<b>11</b>	<b>A</b>	<b>B</b>	<b>C</b>	<b>D</b>
<b>12</b>	<b>A</b>	<b>B</b>	<b>C</b>	<b>D</b>
<b>13</b>	<b>A</b>	<b>B</b>	<b>C</b>	<b>D</b>
<b>14</b>	<b>A</b>	<b>B</b>	<b>C</b>	<b>D</b>
<b>15</b>	<b>A</b>	<b>B</b>	<b>C</b>	<b>D</b>
<b>16</b>	<b>A</b>	<b>B</b>	<b>C</b>	<b>D</b>
<b>17</b>	<b>A</b>	<b>B</b>	<b>C</b>	<b>D</b>
<b>18</b>	<b>A</b>	<b>B</b>	<b>C</b>	<b>D</b>
<b>19</b>	<b>A</b>	<b>B</b>	<b>C</b>	<b>D</b>
<b>20</b>	<b>A</b>	<b>B</b>	<b>C</b>	<b>D</b>