

STUDENT NUMBER

--	--	--	--	--	--	--	--	--	--	--	--	--	--

Letter

# PHYSICS

## Written examination

Wednesday 11 November 2015

Reading time: 2.00 pm to 2.15 pm (15 minutes)

Writing time: 2.15 pm to 4.45 pm (2 hours 30 minutes)

### QUESTION AND ANSWER BOOK

#### Structure of book

<i>Section</i>	<i>Number of questions</i>	<i>Number of questions to be answered</i>	<i>Number of marks</i>
A – Motion in one and two dimensions	7	7	40
Electronics and photonics	4	4	21
Electric power	5	5	40
Interactions of light and matter	6	6	27
	<i>Number of detailed studies</i>	<i>Number of detailed studies to be answered</i>	<i>Number of questions to be answered</i>
B – Detailed studies	6	1	11
			22
			Total 150

- Students are permitted to bring into the examination room: pens, pencils, highlighters, erasers, sharpeners, rulers, pre-written notes (one folded A3 sheet or two A4 sheets bound together by tape) and one scientific calculator.
- Students are NOT permitted to bring into the examination room: blank sheets of paper and/or correction fluid/tape.

#### Materials supplied

- Question and answer book of 72 pages. A formula sheet.
- Answer sheet for multiple-choice questions.

#### Instructions

- Write your **student number** in the space provided above on this page.
- Check that your **name** and **student number** as printed on your answer sheet for multiple-choice questions are correct, **and** sign your name in the space provided to verify this.
- Unless otherwise indicated, the diagrams in this book are **not** drawn to scale.
- All written responses must be in English.

#### At the end of the examination

- Place the answer sheet for multiple-choice questions inside the front cover of this book.

**Students are NOT permitted to bring mobile phones and/or any other unauthorised electronic devices into the examination room.**

**THIS PAGE IS BLANK**

**DO NOT WRITE IN THIS AREA**

## Table of contents

### SECTION A

Area of study	Page
Motion in one and two dimensions .....	4
Electronics and photonics .....	12
Electric power .....	19
Interactions of light and matter .....	28

### SECTION B

#### Detailed study

Einstein's special relativity .....	36
Materials and their use in structures .....	40
Further electronics .....	48
Synchrotron and its applications .....	59
Photonics .....	63
Sound .....	68

**DO NOT WRITE IN THIS AREA**

**TURN OVER**

**SECTION A – Core studies****Instructions for Section A**

Answer **all** questions in this section in the spaces provided. Write using black or blue pen.

Where an answer box has a unit printed in it, give your answer in that unit.

You should take the value of  $g$  to be  $10 \text{ m s}^{-2}$ .

Where answer boxes are provided, write your final answer in the box.

In questions worth more than 1 mark, appropriate working should be shown.

Unless otherwise indicated, diagrams are not to scale.

**Area of study – Motion in one and two dimensions****Question 1** (7 marks)

Block A, of mass  $4.0 \text{ kg}$ , is moving to the right at a speed of  $8.0 \text{ m s}^{-1}$ , as shown in Figure 1. It collides with a stationary block, B, of mass  $8.0 \text{ kg}$ , and rebounds to the left. Its speed after the collision is  $2.0 \text{ m s}^{-1}$ .

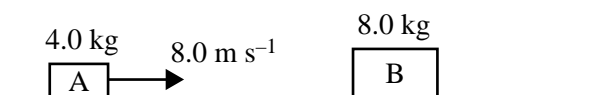
**Figure 1**

- a.** Calculate the speed of block B after the collision.

2 marks

---



---

$\text{m s}^{-1}$

- b.** Explain whether the collision is elastic or inelastic. Include some calculations in your answer.

2 marks

---



---



---



---



---



---



---

c. What are the magnitude, unit and direction of the impulse by block B on block A?

3 marks

---



---



---

Magnitude	Unit	Direction
-----------	------	-----------

**Question 2** (4 marks)

Students set up an experiment as shown in Figure 2.

$M_1$ , of mass 4.0 kg, is connected by a light string (assume it has no mass) to a hanging mass,  $M_2$ , of 1.0 kg. The system is initially at rest. Ignore mass of string and friction.

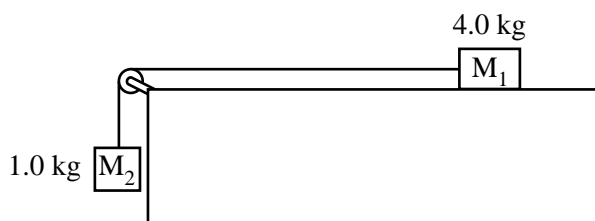

**Figure 2**

The masses are released from rest.

a. Calculate the acceleration of  $M_1$ .

2 marks

---



---

$\text{m s}^{-2}$
-------------------

b. Calculate the magnitude of the tension in the string as the masses accelerate.

2 marks

---



---

N
---

**Question 3** (3 marks)

A model car of mass 2.0 kg is on a track that is part of a vertical circle of radius 4.0 m, as shown in Figure 3. At the lowest point, L, the car is moving at  $6.0 \text{ m s}^{-1}$ . Ignore friction.

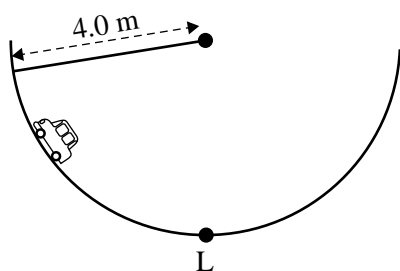

**Figure 3**

- a. At the lowest point (L), draw the resultant force acting on the car as an arrow attached to the car, labelled  $F_R$ .

1 mark

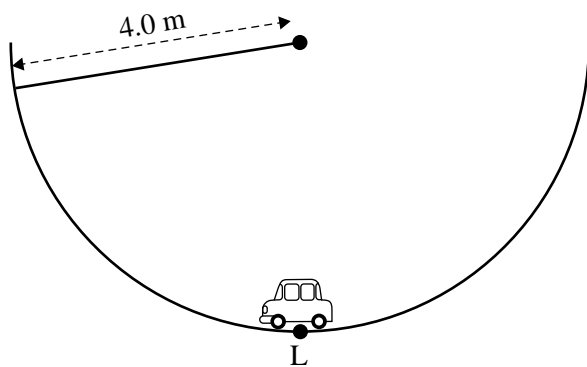

- b. Calculate the magnitude of the force exerted by the track on the car at its lowest point (L). Show your working.

2 marks

---



---



---



---



---

N
---

**Question 4** (6 marks)

Another model car of mass 2.0 kg is placed on a banked circular track. The car follows a path of radius 3.0 m. The motor maintains it at a constant speed of  $2.0 \text{ m s}^{-1}$ , as shown in Figure 4.

The angle of bank is such that there are no sideways frictional forces between the wheels and the track.

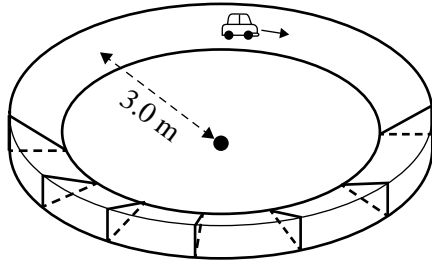

**Figure 4**

- a. On the diagram below, draw the forces acting on the car using solid lines and label each force. Show the resultant force as a dotted line, labelled  $F_R$ .

3 marks

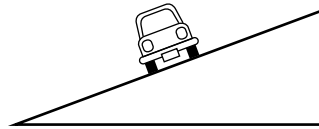

- b. Calculate the required angle of bank of the track, in degrees, to maintain the 2.0 kg car at  $3.0 \text{ m s}^{-1}$  on the 3.0 m circular path with no sideways friction between the wheels and the track. Show your working.

3 marks

---



---



---



---



---

o

**Question 5** (5 marks)

A golfer hits a ball on a part of a golf course that is sloping downwards away from him, as shown in Figure 5.

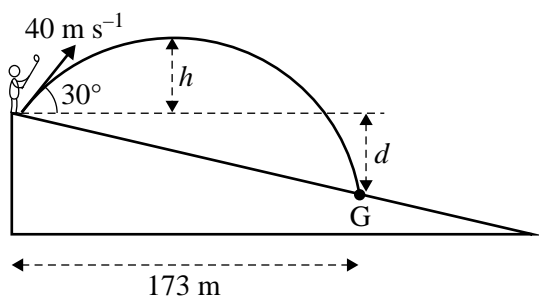

**Figure 5**  
not to scale

The golfer hits the ball at a speed of  $40 \text{ m s}^{-1}$  and at an angle of  $30^\circ$  to the horizontal. Ignore air resistance.

- a. Calculate the maximum height,  $h$ , that the ball rises above its initial position. 2 marks

---

---

---

---

---

---

---

---

m

- b. The ball lands at a point at a horizontal distance of 173 m from the hitting-off point, as shown above. Calculate the vertical drop,  $d$ , from the hitting-off point to the landing point, G. 3 marks

---

---

---

---

---

---

---

---

m



**Question 6** (8 marks)

A mass of 2.0 kg is suspended from a spring, with spring constant  $k = 50 \text{ N m}^{-1}$ , as shown in Figure 6. It is released from the unstretched position of the spring and falls a distance of 0.80 m. Take the zero of gravitational potential energy at its lowest point.

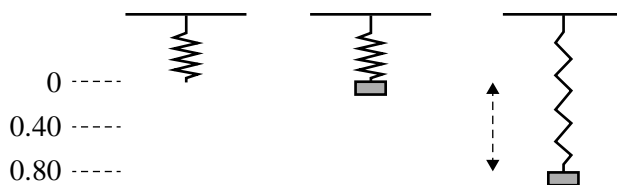
**Figure 6**

- a. Calculate the change in gravitational potential energy as the mass moves from the top position to the lowest position.

1 mark

---



---

J

- b. Calculate the spring potential energy at its lowest point.

2 marks

---



---

J

- c. Calculate the speed of the mass at its midpoint (maximum speed).

3 marks

---



---



---

$\text{m s}^{-1}$

d. Which one of the following graphs (A.–D.) best shows the acceleration of the mass as it goes from the highest point to the lowest point? Take upwards as positive. Give a reason for your choice. 2 marks

A.

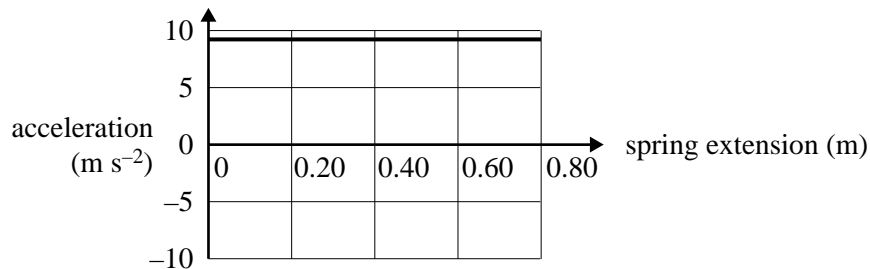

B.

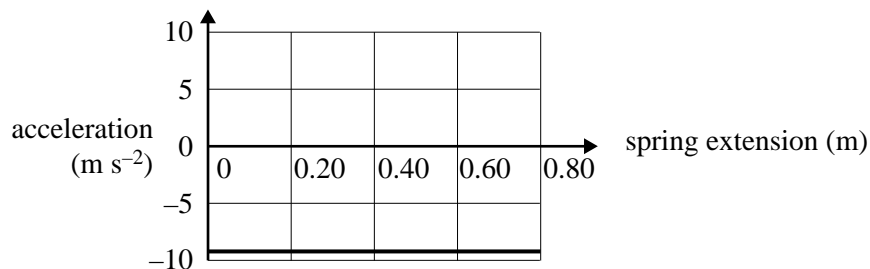

C.

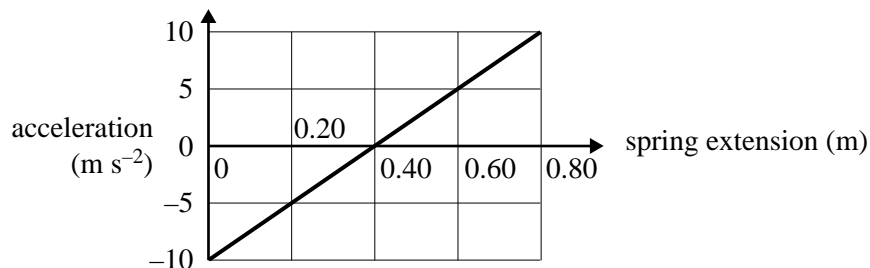

D.

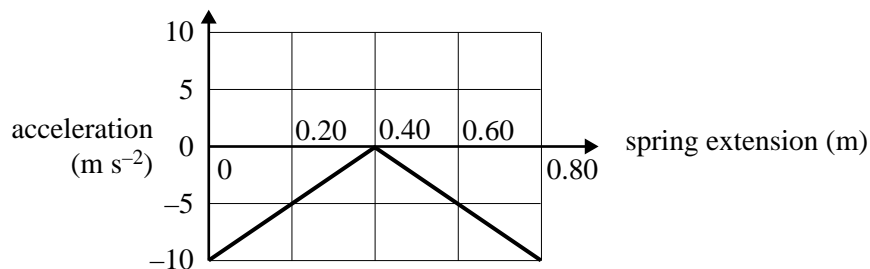



---



---

DO NOT WRITE IN THIS AREA

**Question 7** (7 marks)

A spacecraft is placed in orbit around Saturn so that it is Saturn-stationary (the Saturn equivalent of geostationary – the spacecraft is always over the same point on Saturn’s surface on the equator).

The following information may be needed to answer Question 7:

- mass of Saturn  $5.68 \times 10^{26}$  kg
- mass of spacecraft  $2.0 \times 10^3$  kg
- period of rotation of Saturn 10 hours 15 minutes

a. Calculate the period, in seconds, of this spacecraft’s orbit.

1 mark

---

s
---

b. Calculate the radius of the orbit of the spacecraft to achieve the spacecraft orbit in **part a**.

Show your working.

3 marks

---



---



---



---



---



---



---

m
---

c. Would an astronaut in this spacecraft feel weightless? Explain your answer.

3 marks

---



---



---



---



---



---

### Area of study – Electronics and photonics

#### Question 8 (5 marks)

- a. You are provided with four resistors, each of  $2.0 \Omega$ .

Show how to connect them to produce an effective resistance of  $3.0 \Omega$ , using four or fewer resistors.

Draw in the space below, so that points A and B are at either end of the effective resistance.

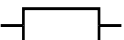
Use this symbol for a resistor: 

Label the resistors in your diagram  $R_1$ ,  $R_2$ ,  $R_3$  and  $R_4$ . If you used fewer resistors, use fewer labels. 2 marks

A  
○

B  
○

- b. The resistor network you have drawn is now constructed and connected correctly to a  $9 V_{DC}$  power supply.

Calculate the voltage drop across each of the resistors and write the value in the table below.

If you used fewer than four resistors, leave the unused resistor box(es) blank. 3 marks

	Voltage drop (V)
$R_1$	
$R_2$	
$R_3$	
$R_4$	

**Question 9** (4 marks)

Two students, Dana and Tin, want to model a telephone system that includes an optical fibre. They connect a microphone, transducer 1, optical fibre, transducer 2, loudspeaker and two amplifiers as shown in Figure 7.

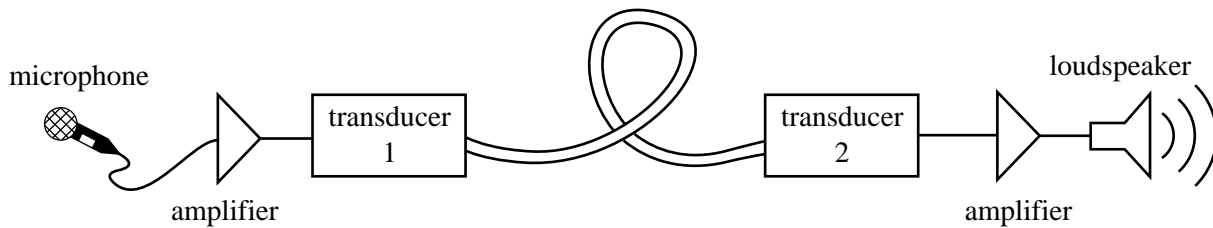
**Figure 7**

The students can select from the following transducers:

- photodiode
- light-dependent resistor (LDR)
- thermistor
- light-emitting diode (LED)

- a. Which transducer from the list above should Dana select for transducer 1? Describe the action of the selected transducer.

2 marks



---



---



---



---

- b. Which transducer from the list above would be the best for Tin to select for transducer 2? Describe the action of the selected transducer.

2 marks



---



---



---



---

**Question 10** (4 marks)

Figure 8 below shows a voltage divider that is used to turn on security lights when the illumination drops below 30 lux. The output voltage,  $V_{out}$  must be 10 V or more for the lights to turn on.

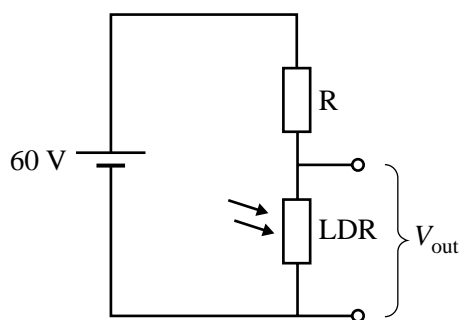

**Figure 8**

Figure 9 shows how the resistance of the LDR varies with illumination.

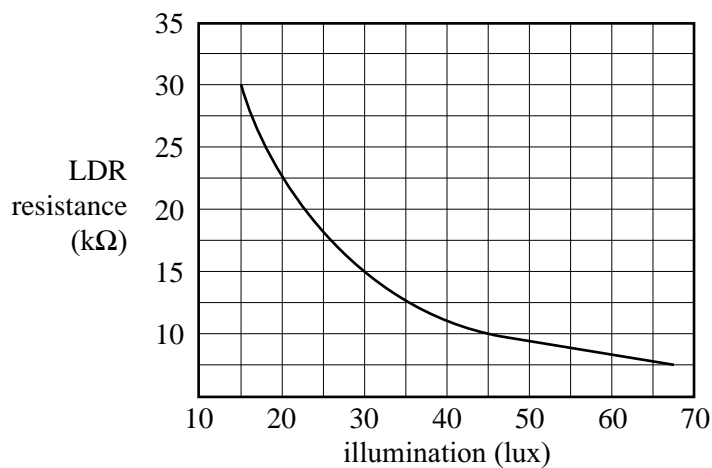

**Figure 9**

- a. What is the resistance of the LDR when the illumination is 30 lux? 1 mark

kΩ

- b. What is the value of the resistor R to produce the required output of 10 V? 3 marks

---



---



---

kΩ

**Question 11** (8 marks)

Two students are investigating an amplifier. They conduct several trials. In the first trial, the input is a sinusoidal signal with a peak voltage of 100 mV, as shown in Figure 10a. Figure 10b shows the output from the amplifier.

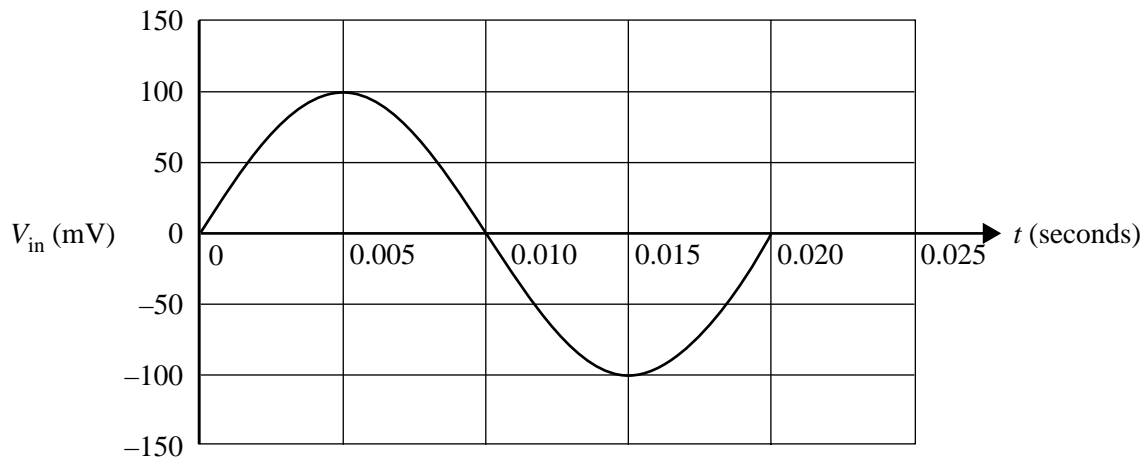
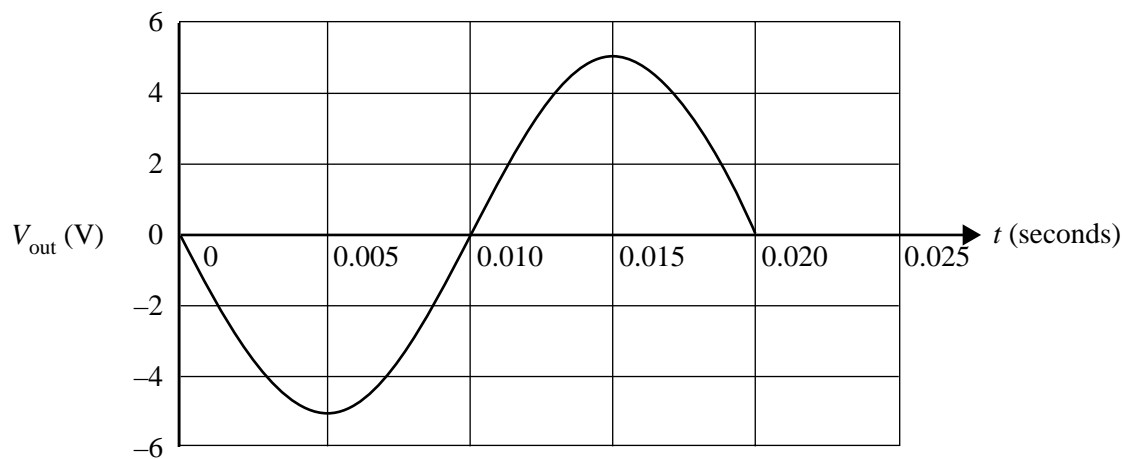
**Figure 10a****Figure 10b**

- a. What is the magnitude of the voltage gain of the amplifier?

2 marks

---



---

In the second trial, the input signal has a peak voltage of 200 mV, as shown in Figure 11a. Figure 11b shows the corresponding output signal.

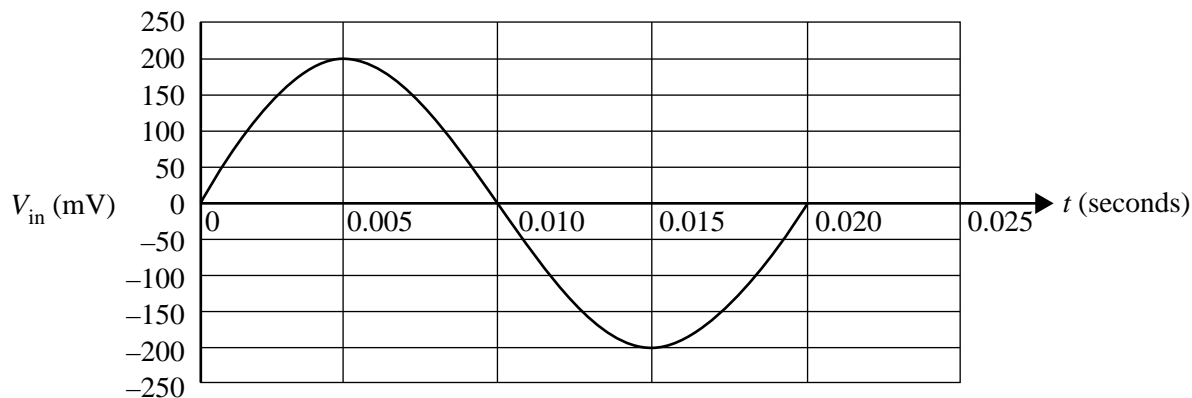

Figure 11a

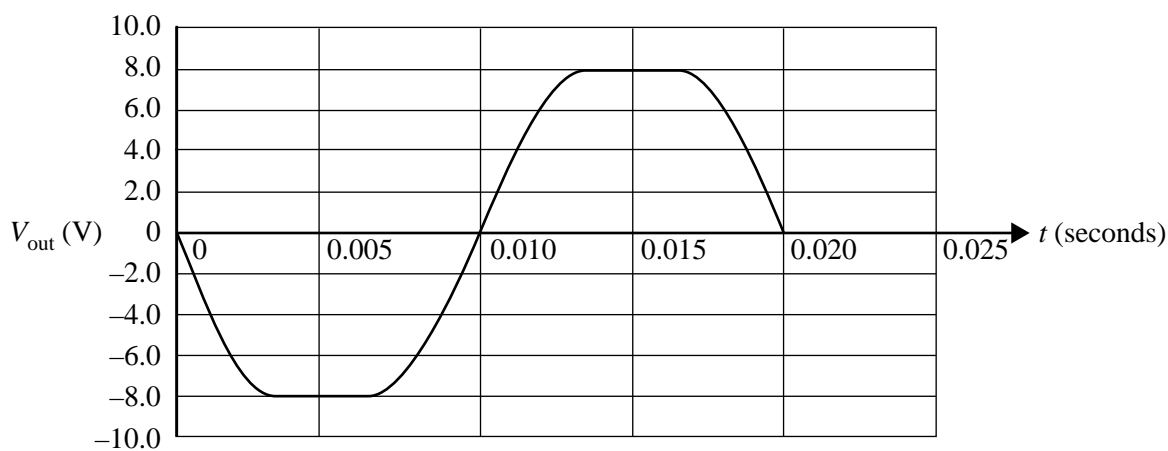

Figure 11b

- b.** Explain why the output signal in the second trial has the shape shown in Figure 11b. 3 marks

---



---



---



---



---



- c. Plot the voltage characteristic of the amplifier,  $V_{\text{out}}$  versus  $V_{\text{in}}$ , using the axes provided. Show the scale on each axis for input,  $V_{\text{in}}$ , between +200 mV and -200 mV.

3 marks

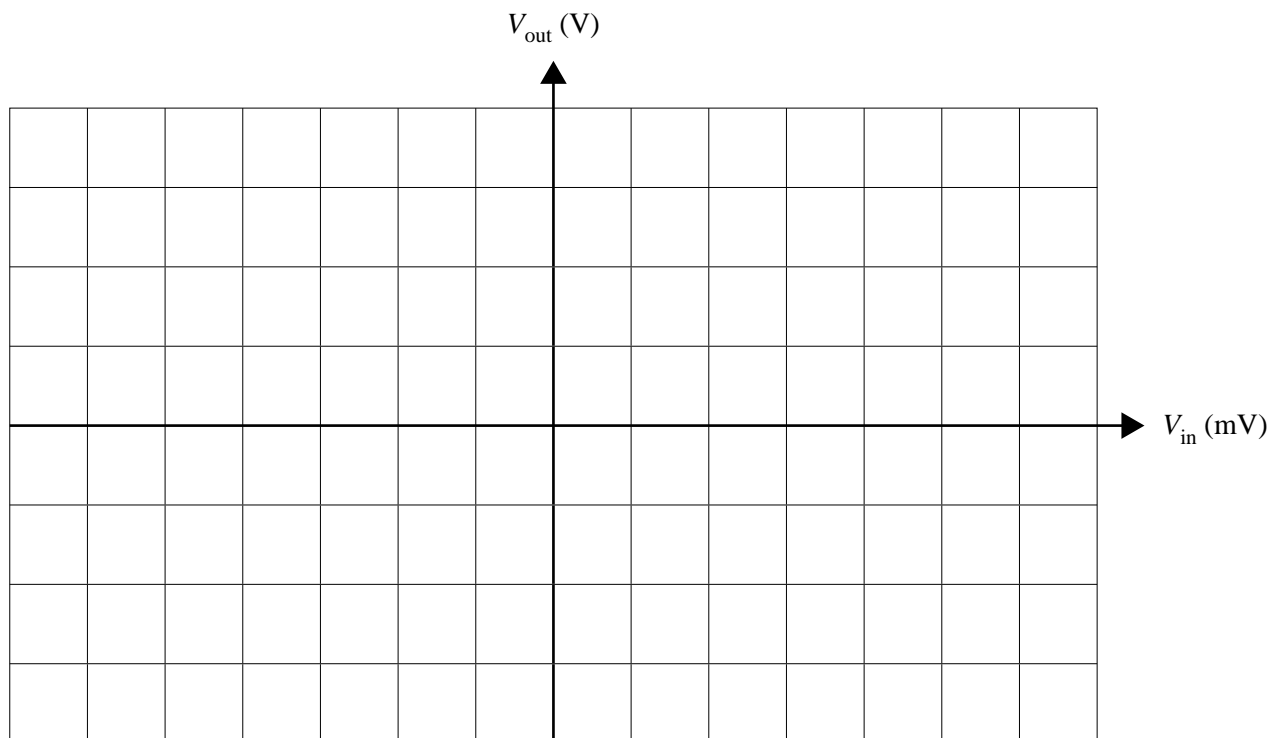

DO NOT WRITE IN THIS AREA

**THIS PAGE IS BLANK**

**DO NOT WRITE IN THIS AREA**

## Area of study – Electric power

### Question 12 (10 marks)

Students have a model that can be used as a motor or generator, depending on the connections used.

The magnets provide a uniform magnetic field of  $2.0 \times 10^{-3}$  tesla.

EFGH is a square coil of each side length 4.0 cm with 10 turns.

A 6.0 V battery and an ammeter are connected to the shaft through a commutator.

This is shown in Figure 12.

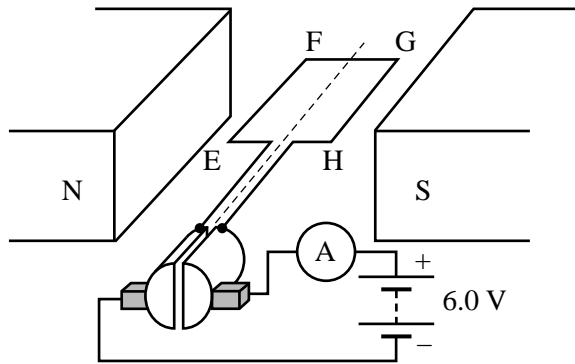

Figure 12

- a. The ammeter shows a current of 4.0 A.

With the coil horizontal as shown in Figure 12, what is the force on the side EF? Give the magnitude and direction (up, down, left, right). Show your working.

3 marks

---



---



---



---



---

Magnitude

N

Direction

The model is now set up as a DC generator, with the output connected to a voltmeter and oscilloscope via a commutator, as shown in Figure 13, with the same coil of side length 4.0 cm and 10 turns, and a uniform magnetic field of  $2.0 \times 10^{-3}$  tesla.

The shaft is rotated by hand.

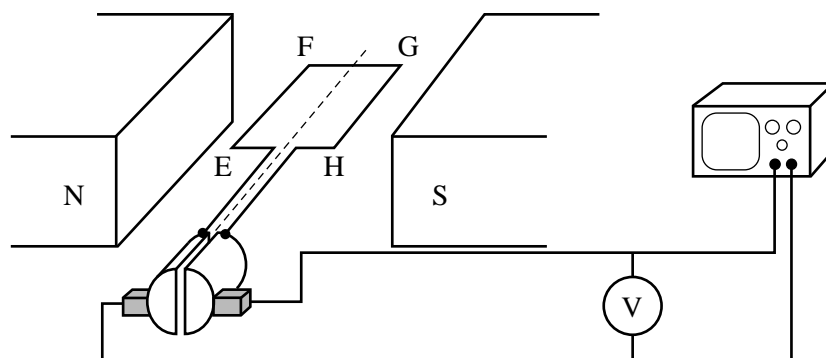
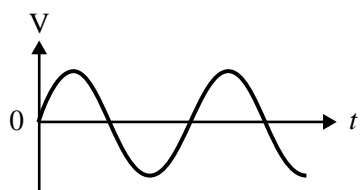

Figure 13

- b. Which one of the following graphs (A.–D.) best shows the voltage output as viewed on the oscilloscope as the coil rotates steadily? (At  $t = 0$ , the coil is horizontal, as shown in Figure 13.)

1 mark

A.



B.

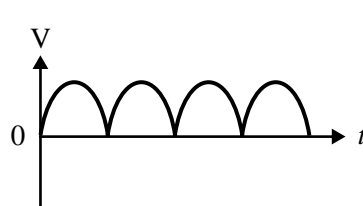

C.

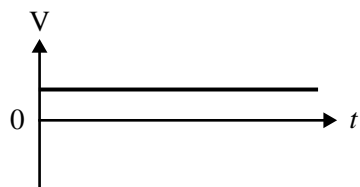

D.

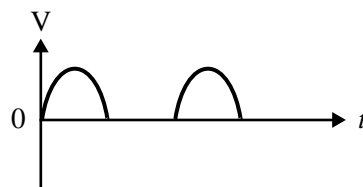

- c. The shaft and coil make two complete revolutions per second.

Calculate the magnitude of the average voltage as shown on the voltmeter during one-quarter revolution. Show your working.

3 marks

---

---

---

mV
----

- d. The students wish to convert this DC generator into an AC generator.

Describe the change or changes the student would have to make to achieve this. Explain your answer. 3 marks

---

---

---

---

DO NOT WRITE IN THIS AREA

**Question 13** (8 marks)

To study electromagnetic induction, students pass a square loop at constant speed through the pole pieces of a magnet, as shown in Figure 14a. Figure 14b shows the experimental set-up as viewed from above. The axes below indicate the same distances as shown in Figure 14b.

In answering Question 13, you do not have to include any calculations or values on the axes.

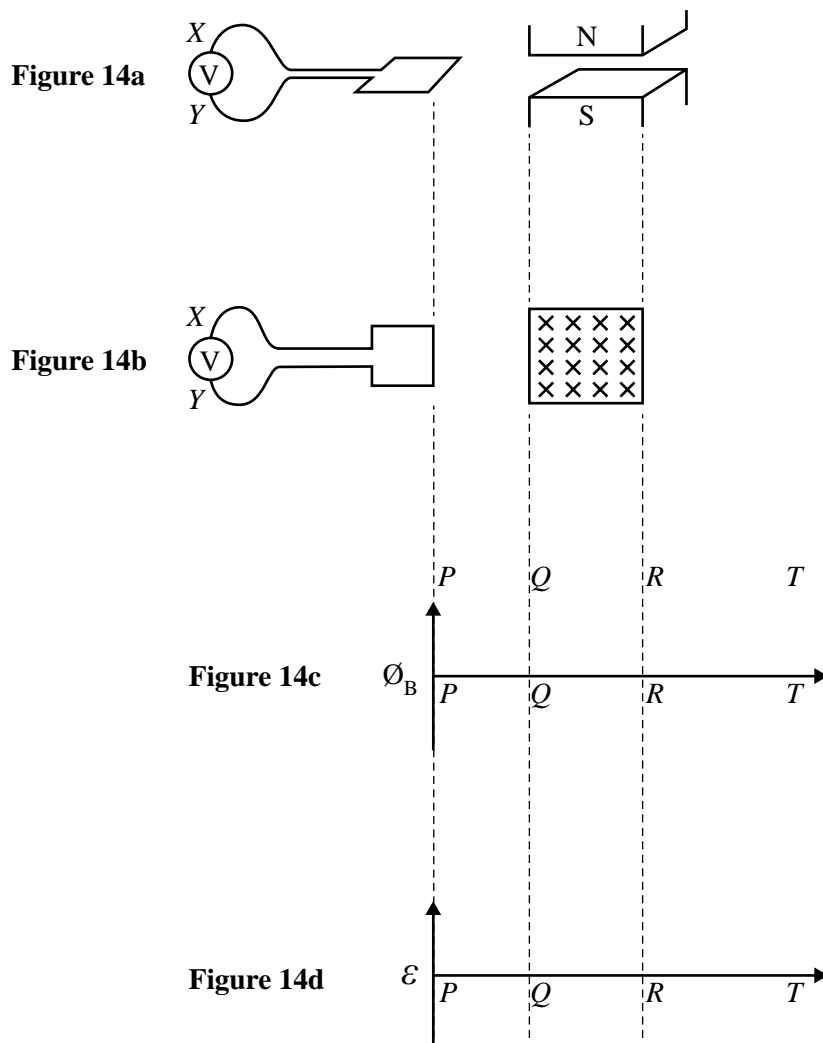

- a. On the axes in Figure 14c, sketch the magnetic flux as the front edge of the loop passes from  $P$  to  $T$ . 2 marks
- b. On the axes in Figure 14d, sketch the emf, as measured by the voltmeter, as the front edge of the loop passes from  $P$  to  $T$ . 2 marks



**Question 14** (4 marks)

A transformer in a substation is used to convert the high voltage of a transmission line to the voltage needed for a factory. The transformer has a ratio of 45:1 of primary to secondary turns.

Electricians use an oscilloscope to test the output (lower voltage) side of the transformer. They observe the following signal, as shown in Figure 15.

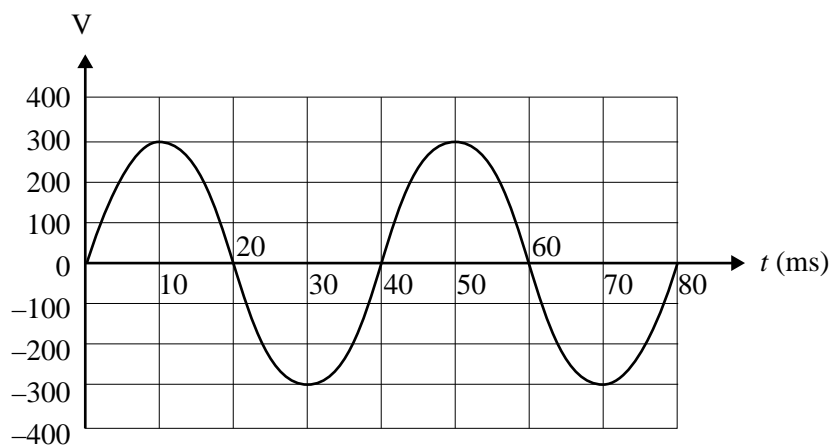

**Figure 15**

- a. Determine the frequency of the AC (alternating current) observed. Show your working. 2 marks

---



---



---



---

Hz

- b. Determine the RMS voltage of the incoming high-voltage input to the transformer. Show your working. 2 marks

---



---



---



---

V



**Question 15** (2 marks)

The diagram below shows a solenoid.

Draw five lines with arrows to show the magnetic field of the solenoid.

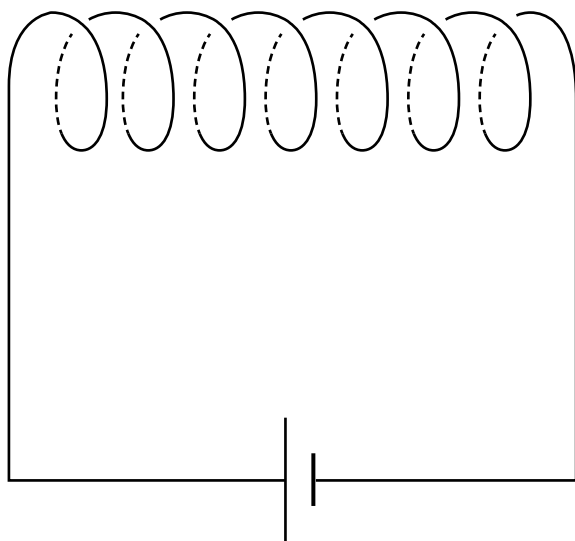

DO NOT WRITE IN THIS AREA

**Question 16** (16 marks)

Two students, Alan and Becky, are constructing a model of an electricity transmission system to demonstrate power loss in transmission lines.

The purpose of the model is to operate a 2.0 V, 4.0 W lamp as the load.

They first set up the model as shown in Figure 16. Each of the transmission lines has a resistance of  $2.0 \Omega$ .

Ignore the resistance of other connecting wires.

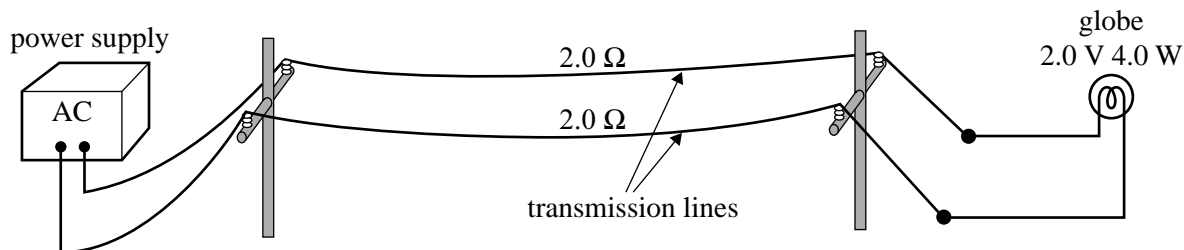

**Figure 16**

The power supply is adjusted so that the lamp is operating correctly (2.0 V, 4.0 W).

- a. Calculate the current in the wires.

2 marks

---



---

A

- b. Calculate the voltage output from the power supply.

2 marks

---



---

V

- c. Calculate the total power loss in the transmission lines. Show your working.

3 marks

---



---



---

W

The students wish to demonstrate how this power loss can be reduced by using a higher transmission voltage involving a step-up and a step-down transformer.

They place a step-up transformer,  $T_1$  (1:10), at the power supply end and a step-down transformer,  $T_2$  (10:1), at the lamp end, as shown in Figure 17. Assume the transformers are ideal; that is, there is no power loss in them. The students adjust the voltage of the power supply so that the lamp operates correctly.

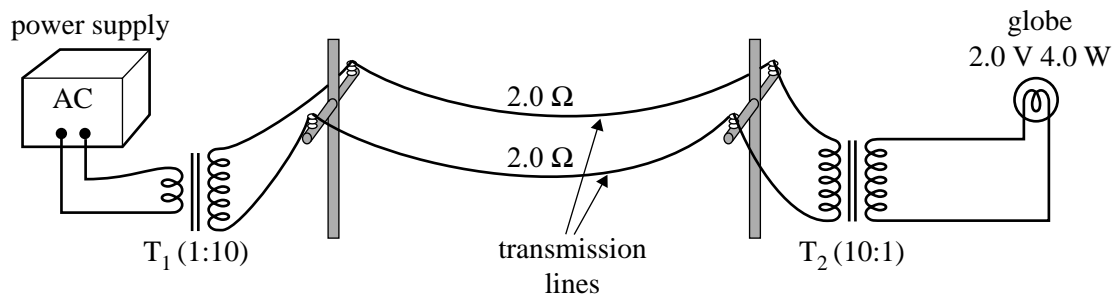

**Figure 17**

- d. Calculate the current in the transmission lines in this situation.

3 marks

---



---



---

A

- e. Calculate the power loss in the transmission lines.

2 marks

---



---

W

- f. Describe a real situation that this model could represent. Explain why the higher transmission voltage is used in terms of power losses you calculated in Alan and Becky's model.

4 marks

---



---



---



---



---

**Area of study – Interactions of light and matter****Question 17** (4 marks)

Two students, Karina and Kim, are investigating double-slit interference. They have a 633 nm wavelength laser and a slide with two narrow slits. They set up their experimental arrangement as shown in Figure 18 and see a pattern of alternating bright and dark bands on their screen.

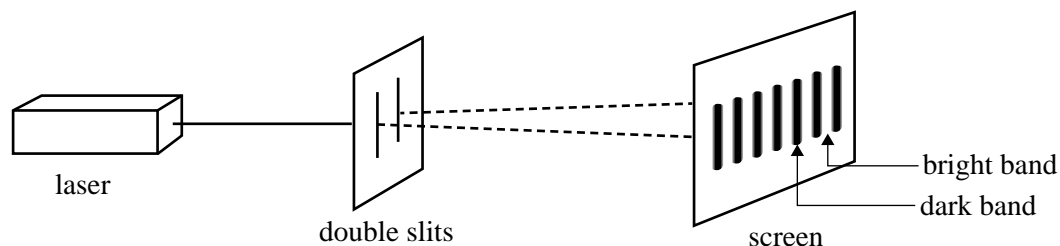
**Figure 18**

- a. Before they put the slide in place, they direct the laser beam onto the screen and mark the bright spot due to the laser on their screen. Kim believes that this point will be a dark band when the slide is put in place. Karina believes it will be a bright band.

Is this point a bright band or a dark band? Give a reason for your choice.

3 marks

---

---

---

---

---

---

---

---

---

---

- b. Next, the students measure the distance between four bright bands as shown in Figure 18. This distance is 6.0 mm. Then they replace the original slits with a second pair of slits and again measure the distance between the four bright bands. The new distance is 8.0 mm.

What must the slit separation of the second pair of slits be?

1 mark

- A. greater than for the original pair
- B. the same as for the original pair
- C. less than for the original pair
- D. not enough information to determine

DO NOT WRITE IN THIS AREA

**Question 18** (6 marks)

Students conduct three different experiments to investigate the photoelectric effect.

For experiment 1, light of various frequencies is shone on the surface of metal A.

Figure 19 shows the graph of maximum kinetic energy,  $E_{K \max}$ , of the photoelectrons against frequency from experiment 1.

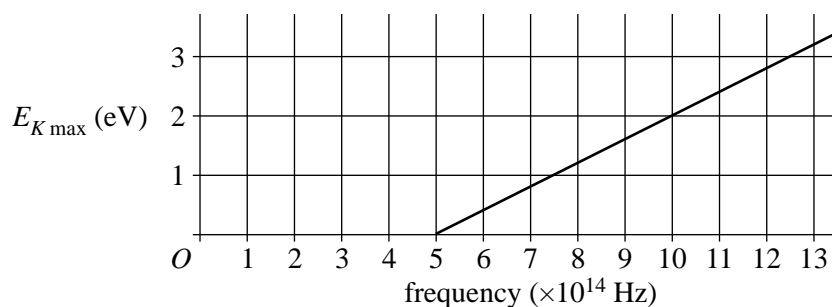
**Figure 19**

- a. Determine the threshold frequency for metal A.

1 mark

---

Hz

- b. Use the graph to calculate the value of Planck's constant for experiment 1.

2 marks

---



---



---



---

eV s

- c. In experiment 2, the intensity of the light of each frequency is doubled and again shone on metal A. A dotted line shows the results of experiment 1.

On the graph below, draw a solid line to sketch the graph of maximum kinetic energy against frequency for experiment 2.

1 mark

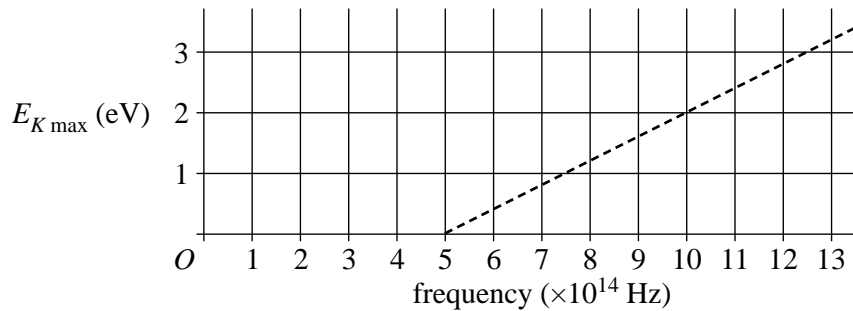

- d. In experiment 3, metal A is replaced with metal B that has a work function 50% larger than that of metal A. The original light intensity is used. A dotted line shows the results of experiment 1.

On the graph below, draw a solid line to sketch the graph of maximum kinetic energy versus frequency for experiment 3.

2 marks

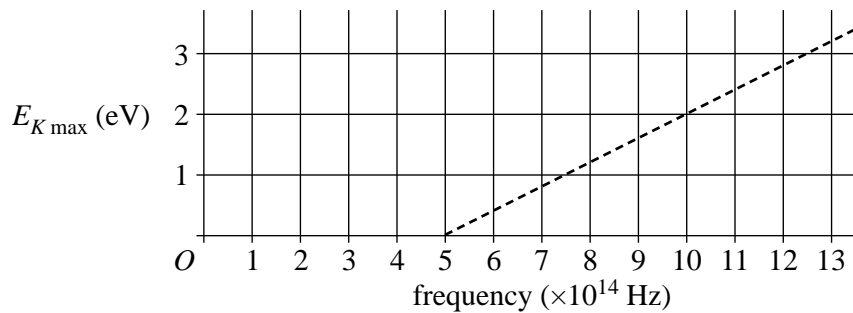

**Question 19** (6 marks)

- a. An atom has a single electron in the second ( $n = 3$ ) excited state. When it returns to the ground ( $n = 1$ ) state, the emission spectrum has lines of  $2.63 \times 10^{16}$  Hz,  $2.22 \times 10^{16}$  Hz and  $0.41 \times 10^{16}$  Hz. This is shown in Figure 20.

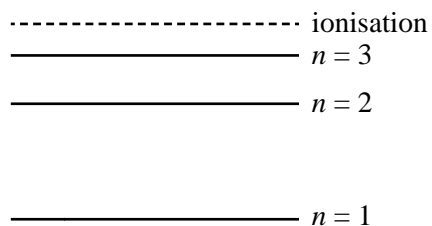
**Figure 20**

Use this information to calculate the energy of the  $n = 2$  and  $n = 3$  states (above the  $n = 1$  ground state). 4 marks

---



---



---



---

$n = 2$   eV      $n = 3$   eV



- b. The energy-level diagram for a different atom is shown in the diagram below.  
Photons of frequency  $7.25 \times 10^{15}$  Hz are observed.

On the diagram, draw in the transition that could lead to this emission line.

2 marks

---



---



---



---

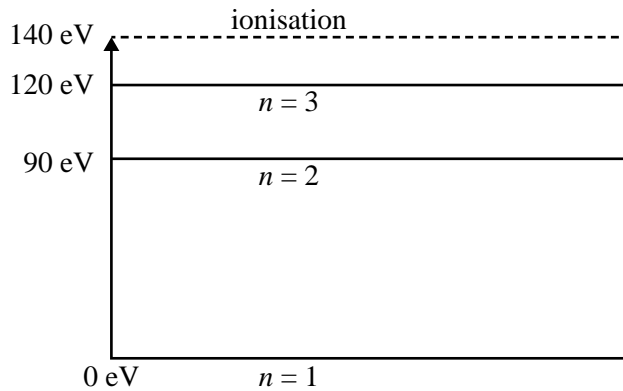

**Question 20** (4 marks)

Physicists use the expression ‘wave-particle duality’ because light sometimes behaves like a particle and electrons sometimes behave like waves.

- a.** What evidence do we have that light can behave like a particle? Explain how this evidence supports a particle model of light.

2 marks

---

---

---

---

---

---

---

- b.** What evidence do we have that electrons can behave like waves? Explain how this evidence supports a wave model of electrons.

2 marks

---

---

---

---

---

---

---

**Question 21** (5 marks)

- a. Use the model of quantised states of the atom to explain why only certain energy levels are allowed. 3 marks

---

---

---

- b. Illustrate your answer with an appropriate diagram. 2 marks

**Question 22** (2 marks)

Electrons (of mass  $9.1 \times 10^{-31}$  kg) have a de Broglie wavelength of  $1.0 \times 10^{-11}$  m.

Calculate the speed of these electrons.

---

---

DO NOT WRITE IN THIS AREA

**END OF SECTION A**  
**TURN OVER**

**SECTION B****Instructions for Section B**

Select **one** Detailed study and answer **all** questions within that Detailed study in pencil on the answer sheet provided for multiple-choice questions.

Show the Detailed study you are answering by shading the matching box on your multiple-choice answer sheet and writing the name of the Detailed study in the box provided.

Choose the response that is **correct** for the question.

A correct answer scores 2, an incorrect answer scores 0.

Marks will **not** be deducted for incorrect answers.

No marks will be given if more than one answer is completed for any question.

**Detailed study 1 – Einstein’s special relativity****Question 1**

One key postulate of Einstein’s special theory of relativity can be described as

- A.  $E = mc^2$ .
- B. nothing can travel faster than the speed of light.
- C. the laws of physics are the same in all inertial (non-accelerated) frames of reference.
- D. all inertial observers obtain the same result when measuring the time and position of an event.

**Question 2**

The following statements reflect views held before Einstein proposed the special theory of relativity.

Which one of these views is now still considered to be true?

- A. The observed speed of light in a medium depends on the speed of an observer relative to that medium.
- B. The speed of light in a region depends only on the values of electric and magnetic properties of that region.
- C. Light is a wave comprising oscillating electric and magnetic fields that cannot travel through empty space.
- D. The inertial frame of a medium in which light is travelling is a special frame and, in that frame, the speed of light is  $c$ .

**Question 3**

A star moving directly away from Earth at speed  $v$  emits light at a particular wavelength. This light is measured on Earth and the wavelength is found to have increased.

Which one of the following is true?

- A. The speed of the light leaving the star is  $c - v$ , causing the frequency of the light source to decrease.
- B. The speed of the light received by the observer on Earth is  $c - v$ , causing the observed wavelength to increase.
- C. The observed change of wavelength is not due to a change in the speed of light, but relative motion of the source and observer.
- D. The observed change of wavelength is due to length contraction resulting from the relative movement of the star with respect to Earth.

Use the following information to answer Questions 4–6.

Spacecraft *S66* is travelling at high speed away from Earth carrying a highly accurate atomic clock. Another spacecraft, *T50*, is travelling in the opposite direction to *S66*, as shown in Figure 1.

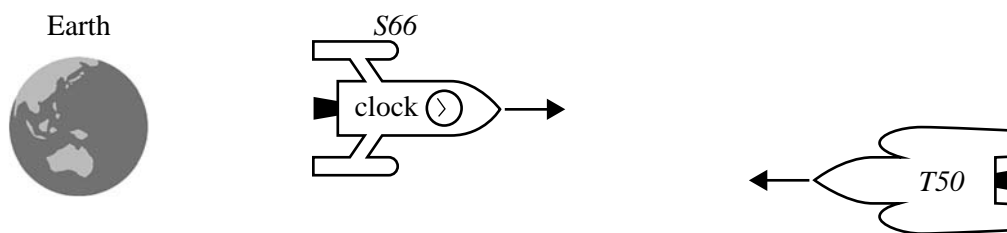

Figure 1

**Question 4**

Which one of the following observers will be able to measure proper time using this clock?

- A. an astronaut seated on spacecraft *S66* five metres behind the clock's position
- B. a scientist on Earth at the clock's original position
- C. no observer can measure proper time since light within the clock moves at the speed of light
- D. the navigator of the other spacecraft, *T50*, travelling at the moment when that navigator is opposite the clock

**Question 5**

An observer, *E*, on Earth emits a short radio pulse to spacecraft *S66*, which reflects it directly back towards the observer. The time elapsed for *E* between sending and receiving the pulse is 20.0 ms.

Which one of the following is true?

- A. According to *E*, spacecraft *S66* was more than 3000 km away when the pulse reached it.
- B. According to *E*, the pulse took longer to reach spacecraft *S66* than it did to return from spacecraft *S66* to *E*.
- C. The 20.0 ms interval measured by *E* is not a proper time because the radio pulse travelled away and back.
- D. According to spacecraft *S66*, the time interval between the signal being sent and being received back by *E* is greater than 20.0 ms.

**Question 6**

The clock on spacecraft *S66* has an indicator showing time intervals of 0.100 s. The navigator of spacecraft *T50* observes that the duration of those time intervals is 0.115 s.

What is the relative speed of spacecraft *S66* to spacecraft *T50*?

- A.  $0.80c$
- B.  $0.70c$
- C.  $0.60c$
- D.  $0.50c$

Use the following information to answer Questions 7 and 8.

Comet-chasing spacecraft *CCS2* travels at a speed for which  $\gamma = 1.5$  relative to the nearest stars. It approaches Comet 203, which is effectively stationary relative to the nearest stars, as shown in Figure 2. There is a landing probe attached to *CCS2*.

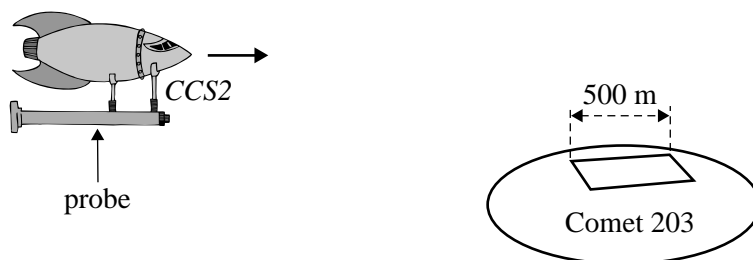

Figure 2

**Question 7**

The designated landing area on the comet has length 500 m in the comet's frame and is parallel to spacecraft *CCS2*'s velocity.

What is the length of this landing area, as measured by instruments on *CCS2*?

- A. 750 m
- B. 500 m
- C. 408 m
- D. 333 m

**Question 8**

Spacecraft *CCS2* releases a probe that will land on the comet. Near touchdown, the probe is at the same velocity as the comet.

Which one of the following is able to measure the proper length for the landing area?

- A. the probe when it is travelling at the same velocity as the comet
- B. *CCS2* because it has far more accurate radar instruments than the probe
- C. *CCS2* at the instant it passes by the landing area on the comet
- D. a radar pulse from *CCS2* because the pulse will momentarily be stationary when it bounces off the landing area

**Question 9**

A nucleus in an excited energy state emits a gamma ray of energy  $1.8 \times 10^{-13}$  J as it decays to its ground state. The initial mass of the excited nucleus is  $M_i$ .

The final mass of the nucleus after decay is

- A.  $M_i + 2 \times 10^{-30}$  kg
- B.  $M_i$
- C.  $M_i - 2 \times 10^{-30}$  kg
- D.  $M_i - 4 \times 10^{-30}$  kg

**Question 10**

A particle of rest mass  $m_0$  is accelerated from rest to  $0.6c$  relative to Earth's frame.

Which one of the following statements is true?

- A. In its own frame, the mass of the particle is now  $1.25m_0$ .
- B. The work done to accelerate the particle is equal to the kinetic energy of the particle.
- C. The kinetic energy of the particle in Earth's frame is  $\frac{1}{2} m_0 (0.6c)^2$ .
- D. The increase in total energy of the particle (measured in Earth's frame) is due to an increase in both the kinetic energy of the particle and the rest energy of the particle.

**Question 11**

According to Einstein's relativity theory, the rest energy is  $m_0c^2$  for a particle of rest mass  $m_0$  and the kinetic energy of the particle is  $(\gamma - 1) m_0c^2$ , where  $\gamma = \frac{1}{\sqrt{1 - \frac{v^2}{c^2}}}$ .

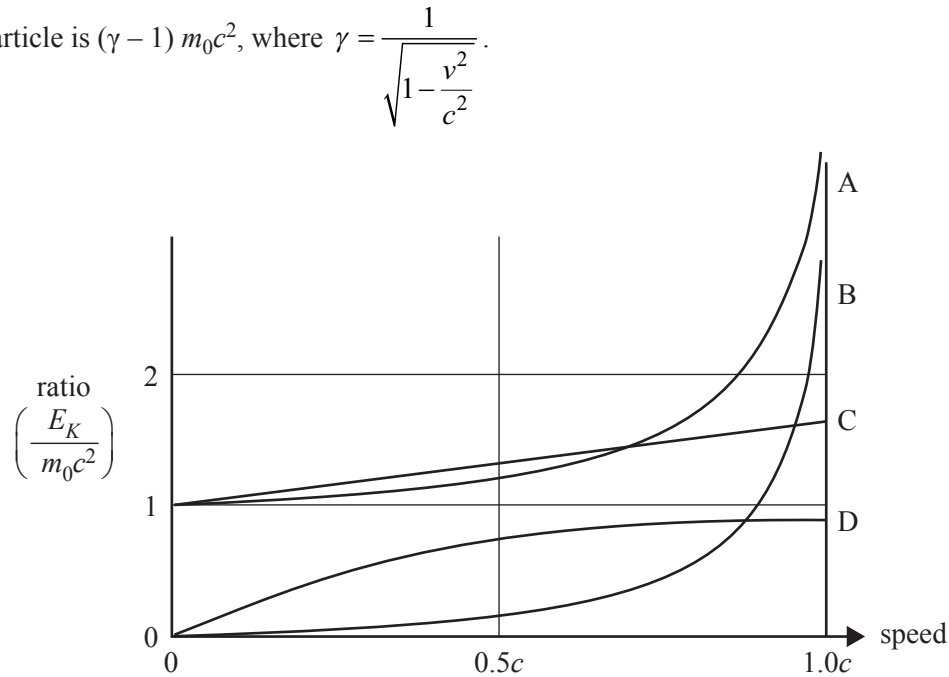

**Figure 3**

Which one of the curves in Figure 3 best gives the relationship of kinetic energy to rest energy

$\left( \frac{E_K}{\text{rest energy}} \right)$  as a function of speed  $v$ ?

- A. curve A
- B. curve B
- C. curve C
- D. curve D

**SECTION B****Instructions for Section B**

Select **one** Detailed study and answer **all** questions within that Detailed study in pencil on the answer sheet provided for multiple-choice questions.

Show the Detailed study you are answering by shading the matching box on your multiple-choice answer sheet and writing the name of the Detailed study in the box provided.

Choose the response that is **correct** for the question.

A correct answer scores 2, an incorrect answer scores 0.

Marks will **not** be deducted for incorrect answers.

No marks will be given if more than one answer is completed for any question.

**Detailed study 2 – Materials and their use in structures****Question 1**

The following diagrams show combinations of forces (as arrows) acting in various places on a cylinder.

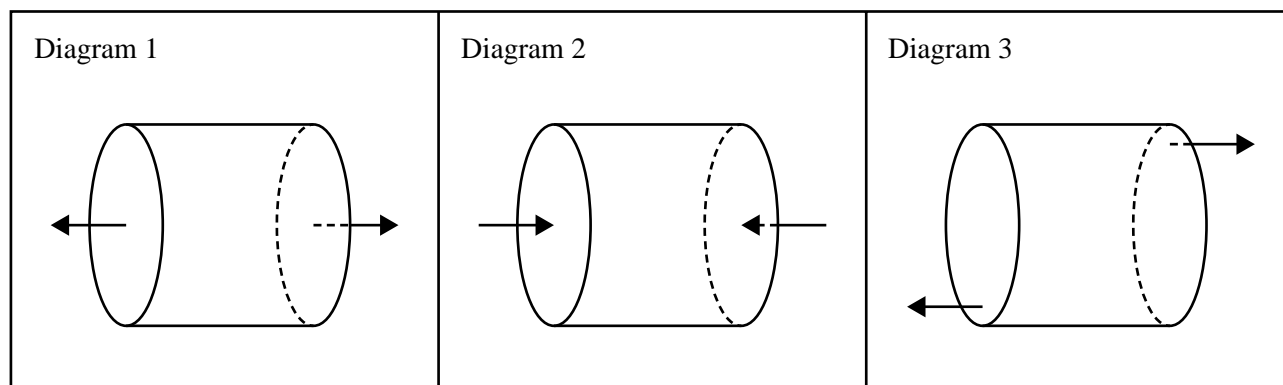

Which of the following best shows the type of force applied to each diagram?

	<b>Diagram 1</b>	<b>Diagram 2</b>	<b>Diagram 3</b>
<b>A.</b>	tension	compression	shear
<b>B.</b>	compression	tension	shear
<b>C.</b>	shear	compression	tension
<b>D.</b>	tension	shear	compression



DO NOT WRITE IN THIS AREA

**CONTINUES OVER PAGE**

**SECTION B – Detailed study 2 – continued**  
**TURN OVER**

Use the following information to answer Questions 2–6.

Samples of four different materials are extended under tension.

Each material has an original length of 10 cm, with a cross-sectional circular area of  $1.5 \times 10^{-3} \text{ m}^2$ .

In Figure 1, the crosses represent fracture (breaking) points. Where applicable, the dots represent the elastic limit of the material.

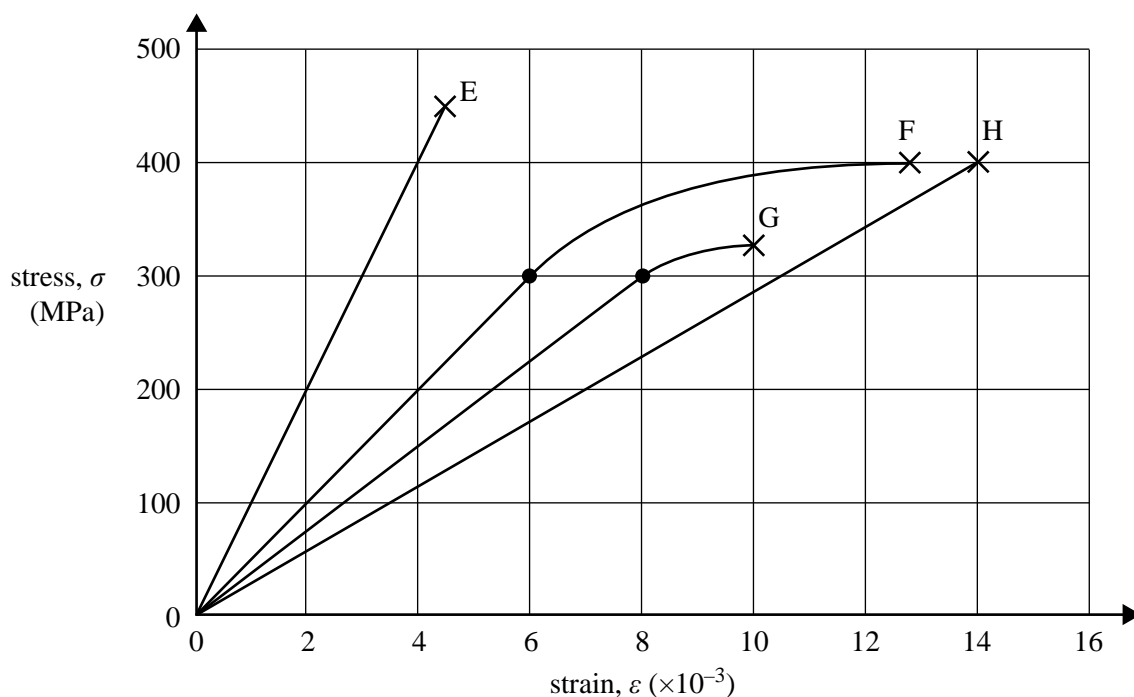

Figure 1

### Question 2

Which material shows elastic behaviour over the greatest range of stress values?

- A. material E
- B. material F
- C. material G
- D. material H

### Question 3

Which one of the following best gives the force required to fracture (break) the sample of material E?

- A. 450 N
- B. 680 N
- C.  $6.8 \times 10^5 \text{ N}$
- D.  $4.5 \times 10^8 \text{ N}$

**Question 4**

Which material would best be described as the toughest?

- A. material E
- B. material F
- C. material G
- D. material H

**Question 5**

Which one of the following values is the best estimate of the total energy required to strain the sample of material F to a strain of  $6.0 \times 10^{-3}$ ?

- A.  $6.0 \times 10^{-3}$  J
- B.  $1.4 \times 10^2$  J
- C.  $1.8 \times 10^6$  J
- D.  $3.0 \times 10^8$  J

**Question 6**

Which one of the following best gives the value of Young's modulus for sample E?

- A. 100 Pa
- B.  $1.0 \times 10^3$  Pa
- C.  $1.0 \times 10^9$  Pa
- D.  $1.0 \times 10^{11}$  Pa

DO NOT WRITE IN THIS AREA

Use the following information to answer Questions 7 and 8.

A design of a bridge is shown in Figure 2. The bridge is to be constructed from three different materials: stone, steel and unreinforced concrete. All three materials must be used in the construction.

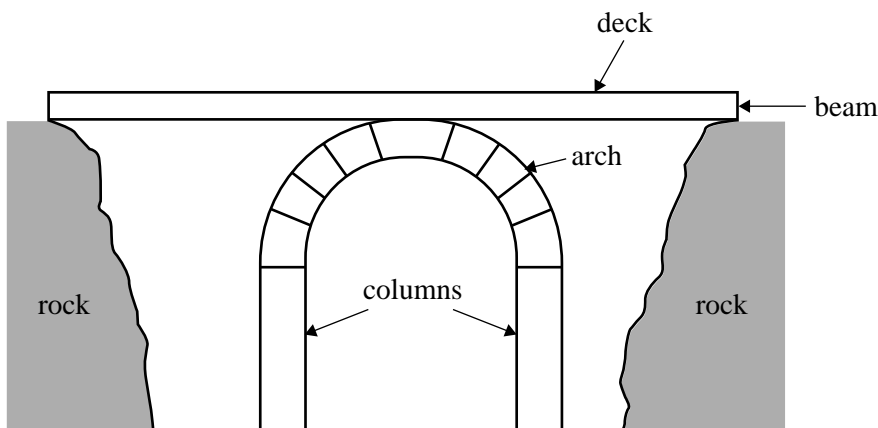

Figure 2

**Question 7**

Which of the following shows the most appropriate use of each of these materials in the construction of the bridge?

	Beam	Arch	Columns
A.	concrete	steel	stone
B.	steel	stone	concrete
C.	stone	concrete	steel
D.	concrete	stone	steel

**Question 8**

The beam of the bridge is to be replaced by a beam made of reinforced concrete, which was not available originally. Which one of the diagrams below shows the best positioning for the reinforcing rods?

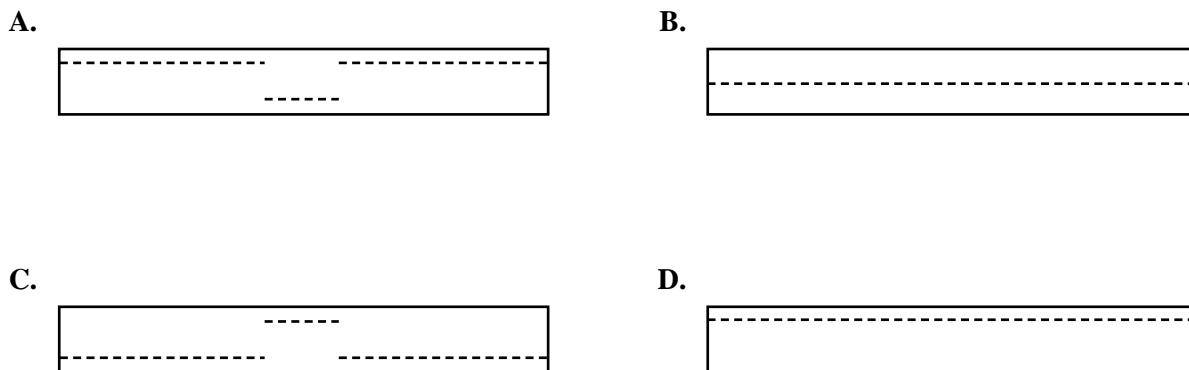

**Question 9**

A student designs a model of a bridge as shown in Figure 3.

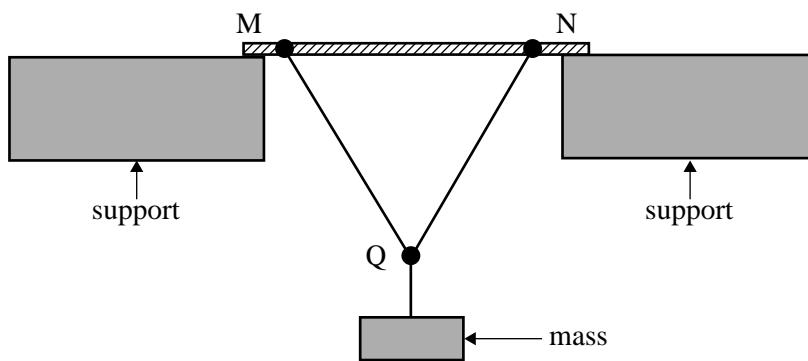

**Figure 3**

Which of the following best shows the state of each of the components?

	MN	MQ	NQ
A.	compression	tension	compression
B.	tension	compression	tension
C.	tension	tension	tension
D.	compression	tension	tension

Use the following information to answer Questions 10 and 11.

A uniform beam, JM, of mass 20 kg and length 10 m is joined to a wall at point M by a frictionless hinge. A cable, KL, connects the beam to the wall, as shown in Figure 4. Ignore the mass of the cable.

A mass of 40 kg hangs from point J with a cable JH.

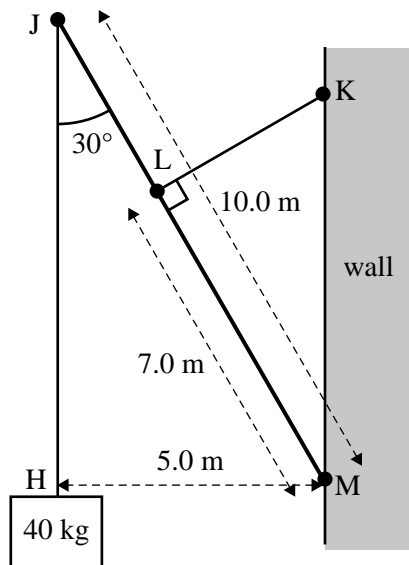

Figure 4

**Question 10**

The torque about the point M due to the 40 kg mass is closest to

- A. 200 N m
- B. 400 N m
- C. 2000 N m
- D. 4000 N m

**Question 11**

The closest value of the tension in KL is

- A. 20 N
- B. 36 N
- C. 200 N
- D. 360 N

DO NOT WRITE IN THIS AREA

**CONTINUES OVER PAGE**

**SECTION B – continued**  
**TURN OVER**

**SECTION B****Instructions for Section B**

Select **one** Detailed study and answer **all** questions within that Detailed study in pencil on the answer sheet provided for multiple-choice questions.

Show the Detailed study you are answering by shading the matching box on your multiple-choice answer sheet and writing the name of the Detailed study in the box provided.

Choose the response that is **correct** for the question.

A correct answer scores 2, an incorrect answer scores 0.

Marks will **not** be deducted for incorrect answers.

No marks will be given if more than one answer is completed for any question.

**Detailed study 3 – Further electronics**

Anna is designing, constructing and testing a smoothed, regulated  $5\text{ V}_{\text{DC}}$  power supply operated from a  $50\text{ Hz}$ ,  $240\text{ V}_{\text{RMS}}$  AC supply.

Before beginning to assemble the power supply, she tests various components separately.

Anna begins by testing the transformer using the circuit shown in Figure 1.

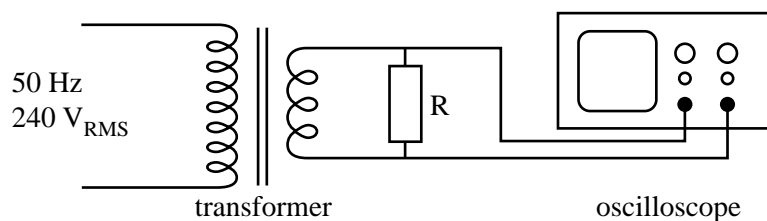

**Figure 1**



**Question 1**

The input is 50 Hz, 240 V<sub>RMS</sub> AC. The transformer has 4800 turns in the primary and 240 turns in the secondary. Assume it is an ideal transformer. The output is connected to an oscilloscope.

Which one of the following best shows the display Anna will see on the oscilloscope?

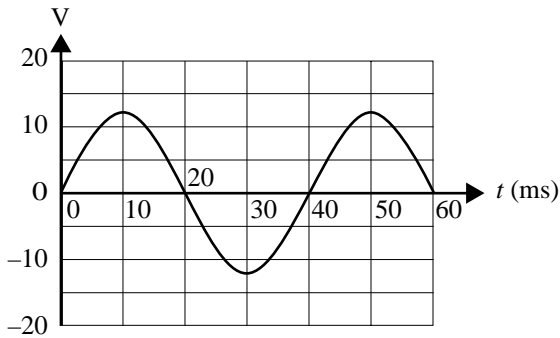
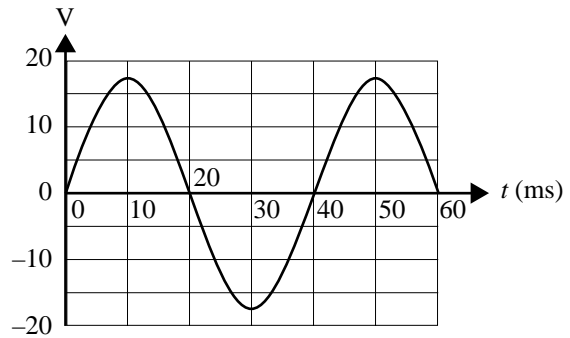
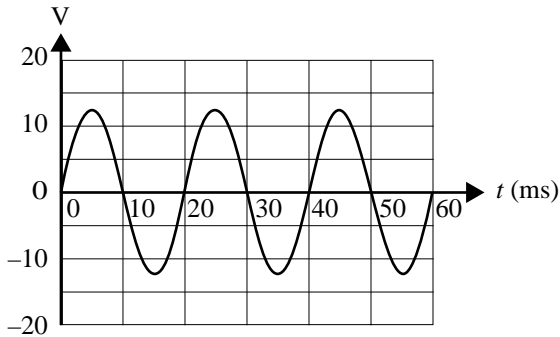
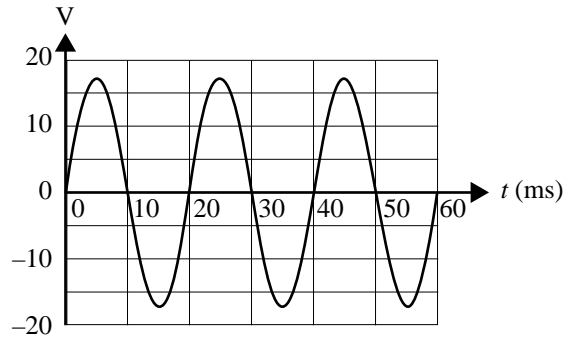
**A.****B.****C.****D.**

Use the following information to answer Questions 2–4.

Figure 2 shows the characteristics of the diodes Anna uses in constructing the power supply.

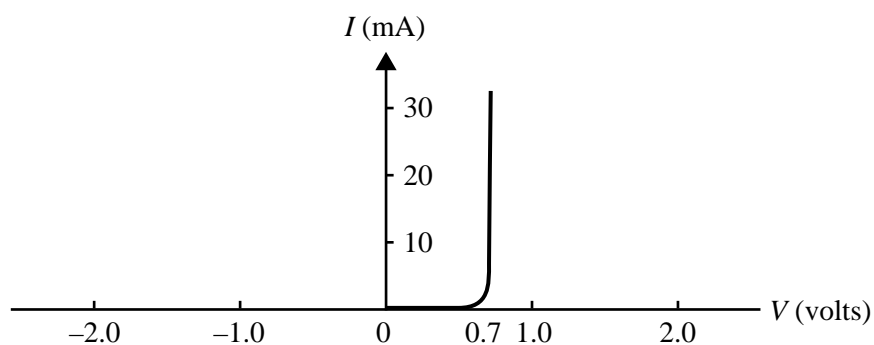

Figure 2

Anna tests a diode by setting up the circuit shown in Figure 3.

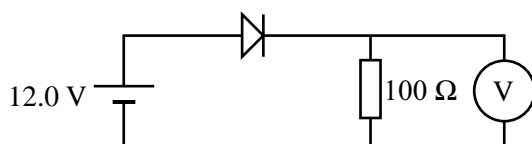

Figure 3

**Question 2**

Which one of the following best gives the voltage that will be observed across the voltmeter V?

- A. 12.7 V
- B. 12 V
- C. 11.3 V
- D. 10.6 V

**Question 3**

Anna next sets up a bridge rectifier using four of the diodes. The circuit is shown in Figure 4.

She finds it does not operate correctly as diode 1 has become faulty (acts as an open circuit) because the circuit is incorrectly set up.

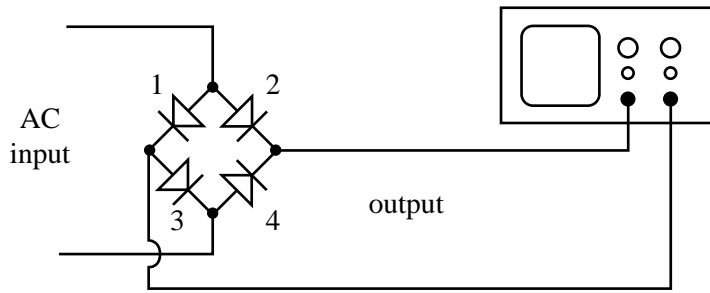

**Figure 4**

Which one of the following displays would be seen on the oscilloscope?

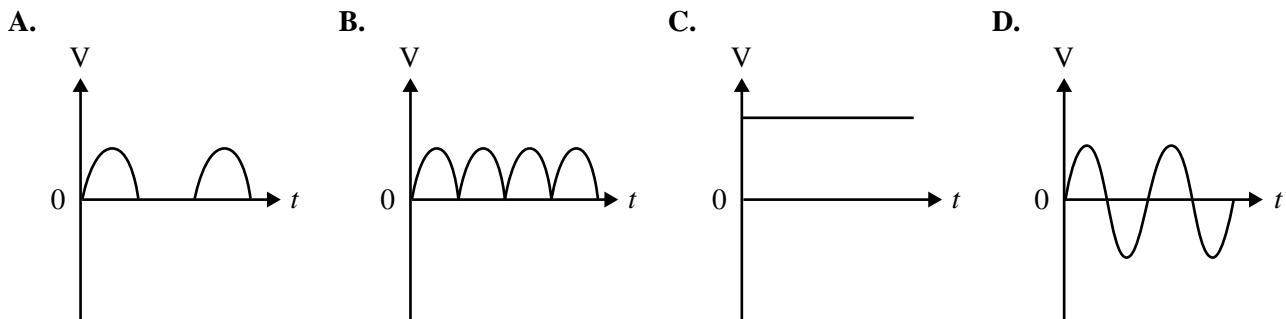
**Question 4**

Anna now correctly sets up the bridge rectifier.

Which one of the following circuits shows the correct arrangement?

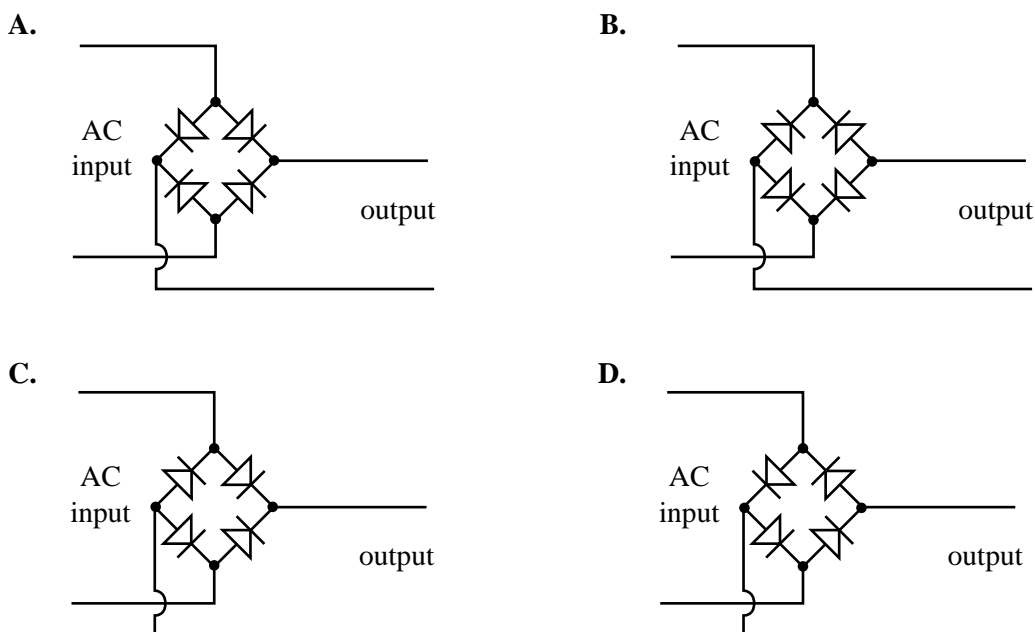

**Question 5**

Anna next tests a capacitor. She sets up the circuit as shown in Figure 5.

The capacitor has a value of  $10\ \mu\text{F}$ .

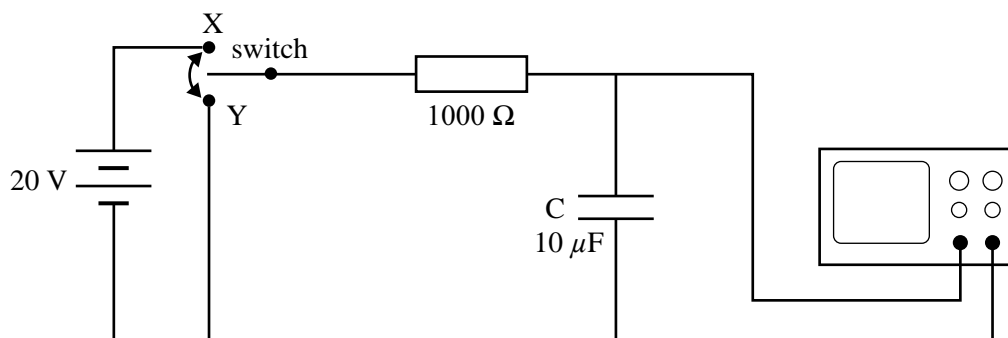

**Figure 5**

With the capacitor discharged, she moves the switch to position X.

Which one of the following shows the display she will see on the oscilloscope?

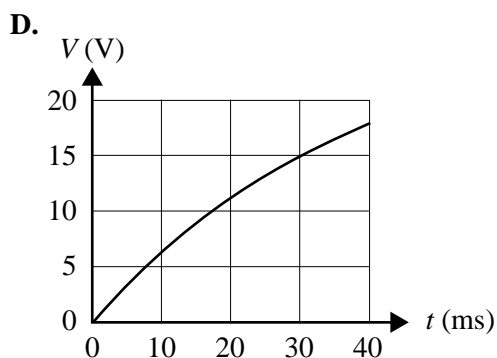
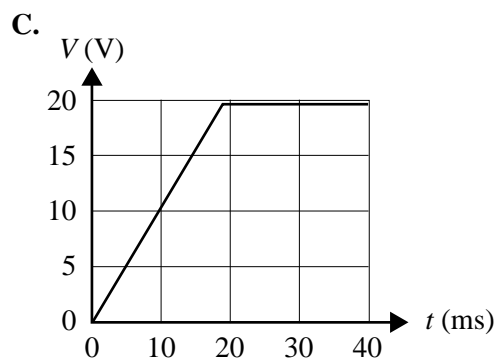
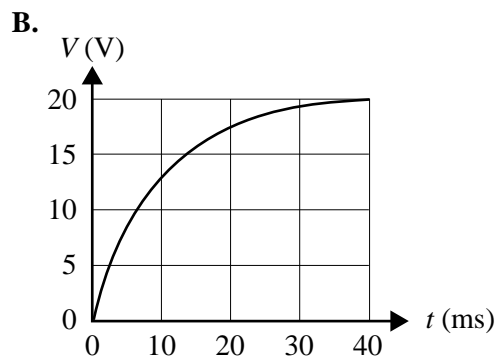
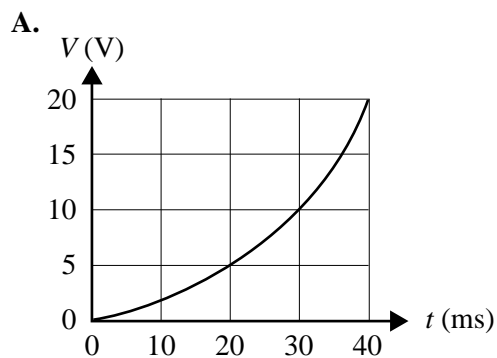

**Question 6**

Using the same capacitor, Anna sets up the circuit shown in Figure 6.

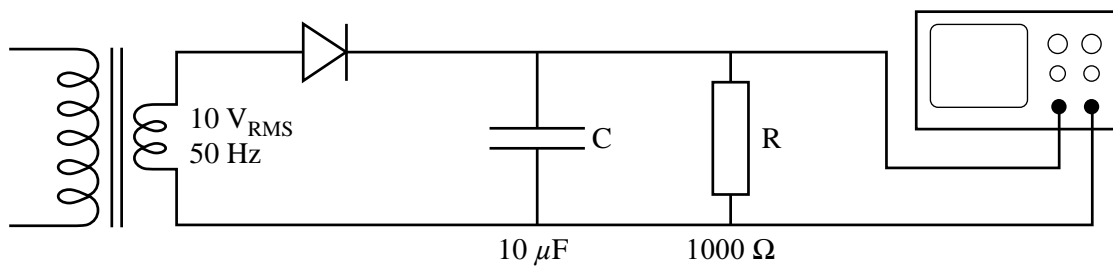
**Figure 6**

Which one of the following would most likely be the display seen on the oscilloscope?

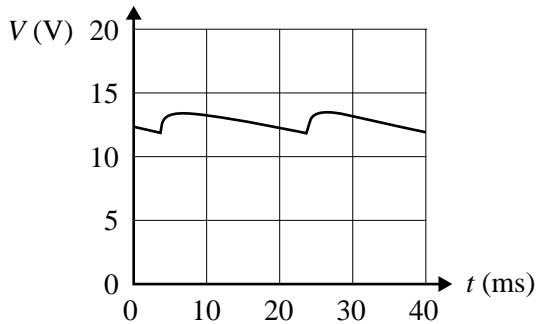
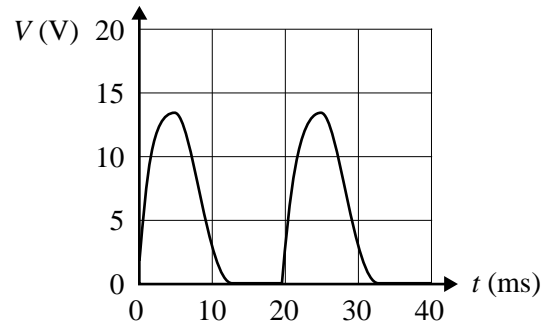
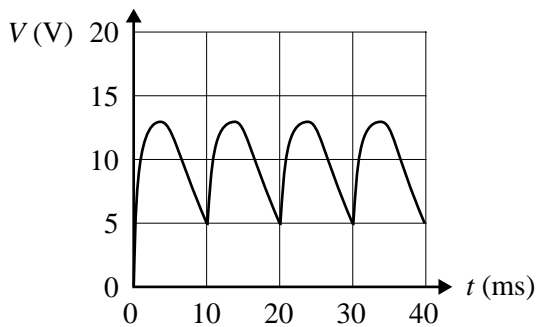
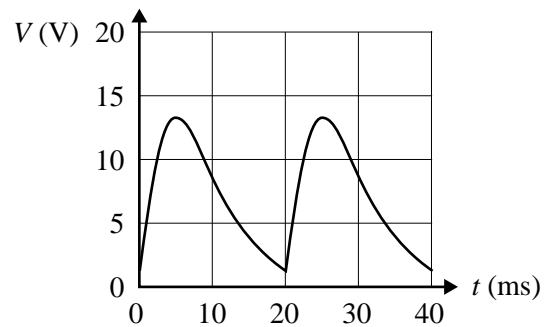
**A.****B.****C.****D.**

Use the following information to answer Questions 7 and 8.

Anna next tests a Zener diode. She sets up the circuit with a  $7.0 \text{ V}_{\text{DC}}$  power supply, as shown in Figure 7.

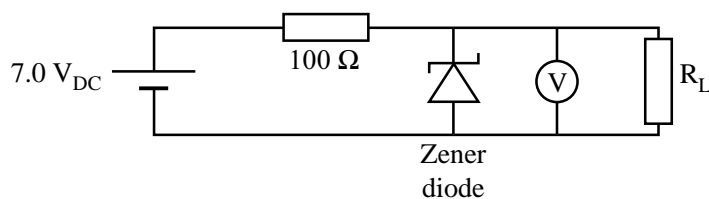

Figure 7

**Question 7**

Anna measures the voltage across the Zener diode to be  $5.0 \text{ V}_{\text{DC}}$ .

Which one of the following graphs would best indicate the characteristics of the Zener diode used?

A.

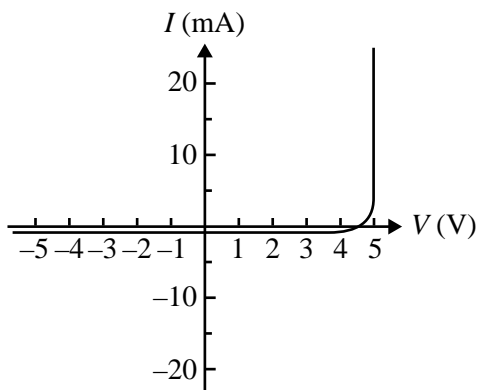

B.

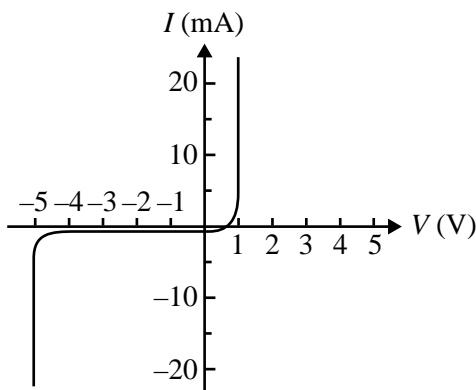

C.

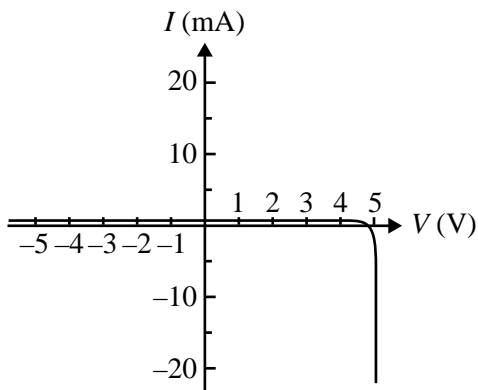

D.

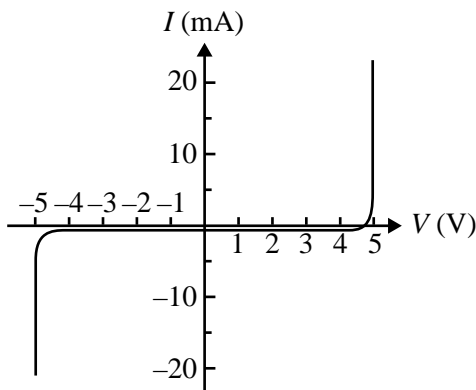

**Question 8**

Which one of the following best gives the current through the  $100 \Omega$  resistor?

- A. 70 mA
- B. 50 mA
- C. 20 mA
- D. 0 mA

DO NOT WRITE IN THIS AREA

**CONTINUES OVER PAGE**

**SECTION B – Detailed study 3 – continued**  
**TURN OVER**

Use the following information to answer Questions 9–11.

Anna now sets up the complete circuit as shown in Figure 8.

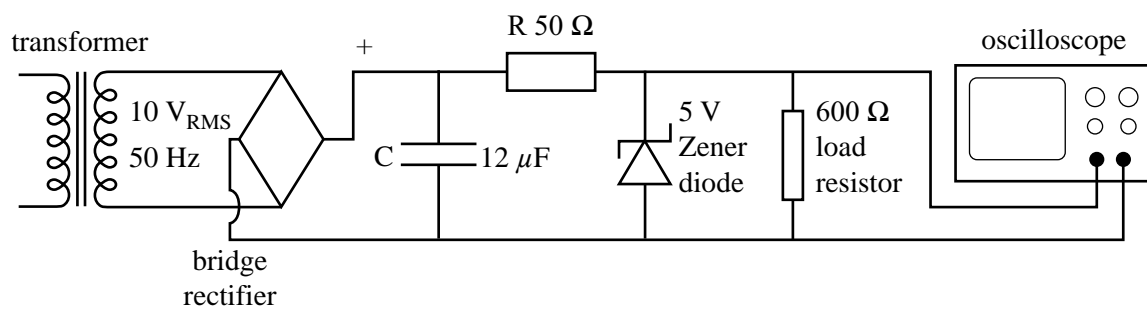

**Figure 8**

With the circuit operating correctly, she sees the following display on the oscilloscope, as shown in Figure 9.

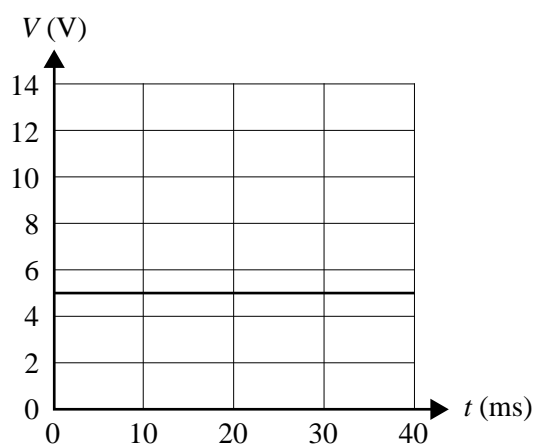

**Figure 9**



After a period of this circuit operating correctly, various components fail, one at a time.

**Question 9**

One of the diodes fails, so that no current can pass through it.

Which one of the following displays would Anna now observe on the oscilloscope?

**A.**

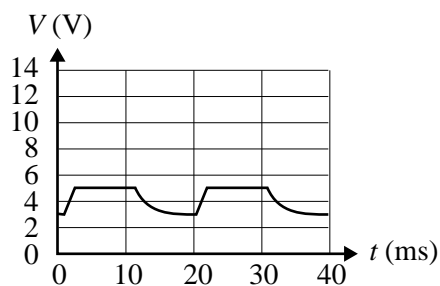

**B.**

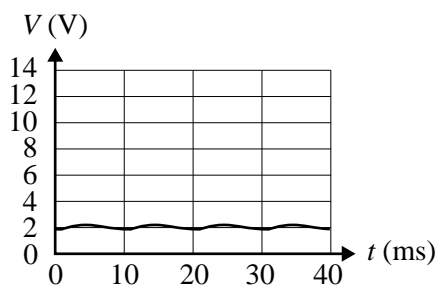

**C.**

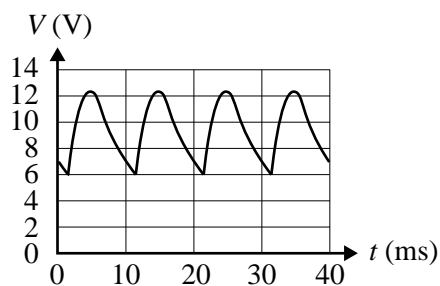

**D.**

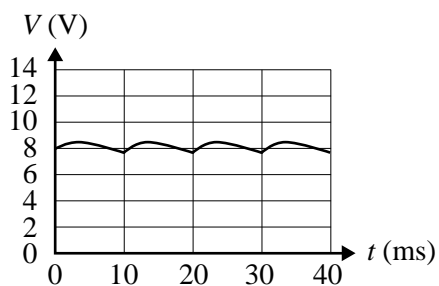

DO NOT WRITE IN THIS AREA

**Question 10**

The failed rectifier diode is replaced. The  $50\ \Omega$  resistor,  $R$ , fails, so that it now has a resistance of  $3000\ \Omega$  instead of  $50\ \Omega$ .

Which one of the following displays would Anna now observe on the oscilloscope?

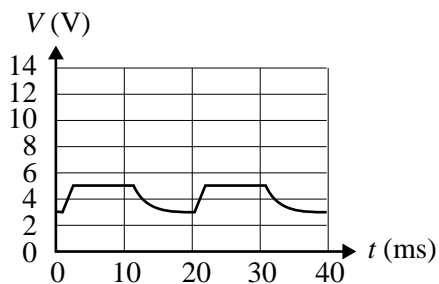
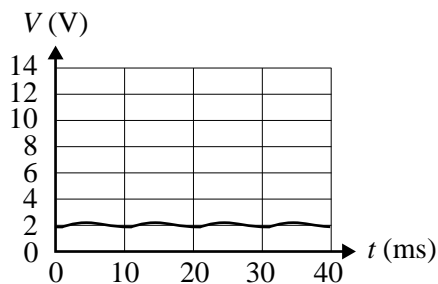
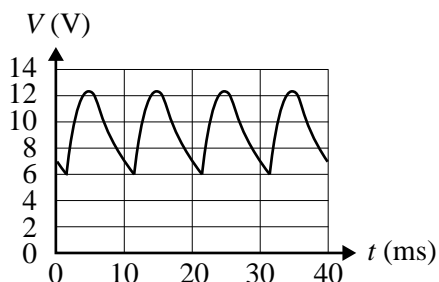
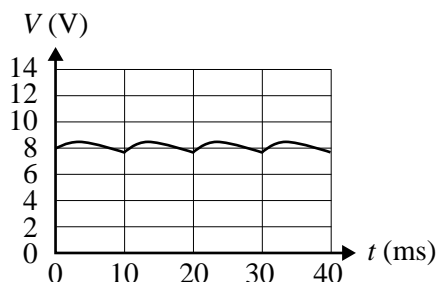
**A.****B.****C.****D.****Question 11**

The failed resistor  $R$  is replaced with a new  $50\ \Omega$  resistor. The Zener diode now fails, so that it has infinite resistance (open circuit).

Which one of the following displays would Anna now observe on the oscilloscope?

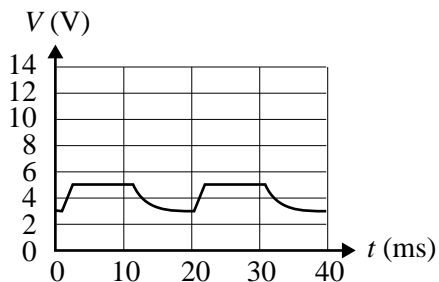
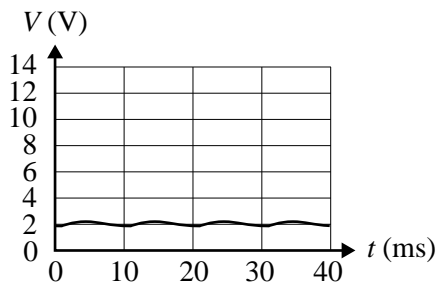
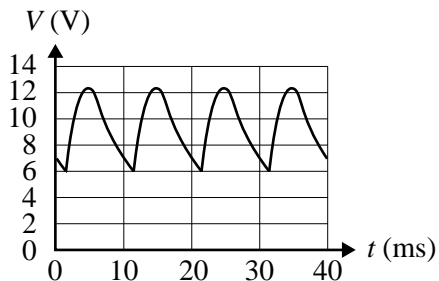
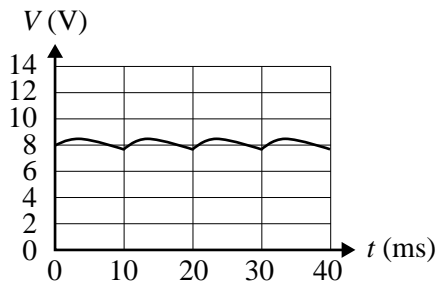
**A.****B.****C.****D.**

**SECTION B****Instructions for Section B**

Select **one** Detailed study and answer **all** questions within that Detailed study in pencil on the answer sheet provided for multiple-choice questions.

Show the Detailed study you are answering by shading the matching box on your multiple-choice answer sheet and writing the name of the Detailed study in the box provided.

Choose the response that is **correct** for the question.

A correct answer scores 2, an incorrect answer scores 0.

Marks will **not** be deducted for incorrect answers.

No marks will be given if more than one answer is completed for any question.

**Detailed study 4 – Synchrotron and its applications****Question 1**

Four synchrotron components are described in the table below.

Which of the following best describes the four synchrotron components?

	<b>Beamline</b>	<b>Storage ring</b>	<b>Electron gun</b>	<b>Booster ring</b>
<b>A.</b>	electron beam travels to work station	electron beam accelerated to maximum speed	initial acceleration of photons	electron beam accelerated to produce photons
<b>B.</b>	light beam travels to work station	electron beam accelerated to produce photons	electrons produced	electron beam accelerated to maximum speed
<b>C.</b>	electron beam travels to work station	electron beam accelerated to maximum speed	electrons produced	electron beam accelerated to produce photons
<b>D.</b>	light beam travels to work station	electron beam accelerated to produce photons	initial acceleration of photons	electron beam accelerated to maximum speed

**Question 2**

In which part of the synchrotron is an insertion device, such as an undulator, located?

- A.** storage ring
- B.** booster ring
- C.** beamline
- D.** electron linac

**Question 3**

Denise and Thomas want to investigate a crystal structure using X-rays. They may choose between using an X-ray tube in their own laboratory or using the Australian Synchrotron.

Which one of the following best gives an advantage of using the Australian Synchrotron over using an X-ray tube to investigate a crystal structure using X-ray diffraction?

- A. The synchrotron provides infrared radiation, but the X-ray tube cannot.
- B. Synchrotron radiation is brighter than the radiation from an X-ray tube.
- C. Synchrotron radiation is less bright than the radiation from an X-ray tube.
- D. Synchrotron radiation always has a shorter wavelength than radiation from an X-ray tube.

**Question 4**

Which statement best describes how the light beam provided by the synchrotron meets the needs of the diffraction experiment to investigate the crystal lattice structure?

- A. The light beam from a bending magnet or insertion device is collimated by slits and a very narrow range of wavelengths is selected by a device within the beamline.
- B. The light beam used is directly taken from a bending magnet, with a relatively broad angular spread and a wide range of wavelengths.
- C. The light beam used is directly taken from a bending magnet, with a very narrow beam and a very narrow range of wavelengths.
- D. The light beam used is directly taken from an insertion device, with a very narrow beam and a very broad range of wavelengths.

**Question 5**

A bending magnet causes an electron beam moving at  $1.5 \times 10^6 \text{ m s}^{-1}$  to change direction through one-quarter of a circle of radius 0.50 m.

The magnitude of the magnetic field is

- A.  $7.0 \times 10^{-5} \text{ T}$
- B.  $4.3 \times 10^{-6} \text{ T}$
- C.  $3.2 \times 10^{-2} \text{ T}$
- D.  $1.7 \times 10^{-5} \text{ T}$

**Question 6**

Electrons are accelerated from rest in an electron gun by a potential difference of 50 kV.

What is their final speed? (Ignore relativistic effects.)

- A.  $1.0 \times 10^5 \text{ m s}^{-1}$
- B.  $4.7 \times 10^7 \text{ m s}^{-1}$
- C.  $1.3 \times 10^8 \text{ m s}^{-1}$
- D.  $2.9 \times 10^8 \text{ m s}^{-1}$

**Question 7**

In Compton or inelastic scattering, after interacting with electrons, X-rays have

- A. a greater energy absorbed from thermal motion of electrons.
- B. an increase in wavelength.
- C. a decrease in wavelength.
- D. unchanged wavelength.

Use the following information to answer Questions 8 and 9.

A crystal structure is investigated using Bragg diffraction with X-rays of wavelength 0.15 nm. The graph in Figure 1 shows X-ray intensity versus diffraction angle  $\theta$ , for one particular set of atomic planes.

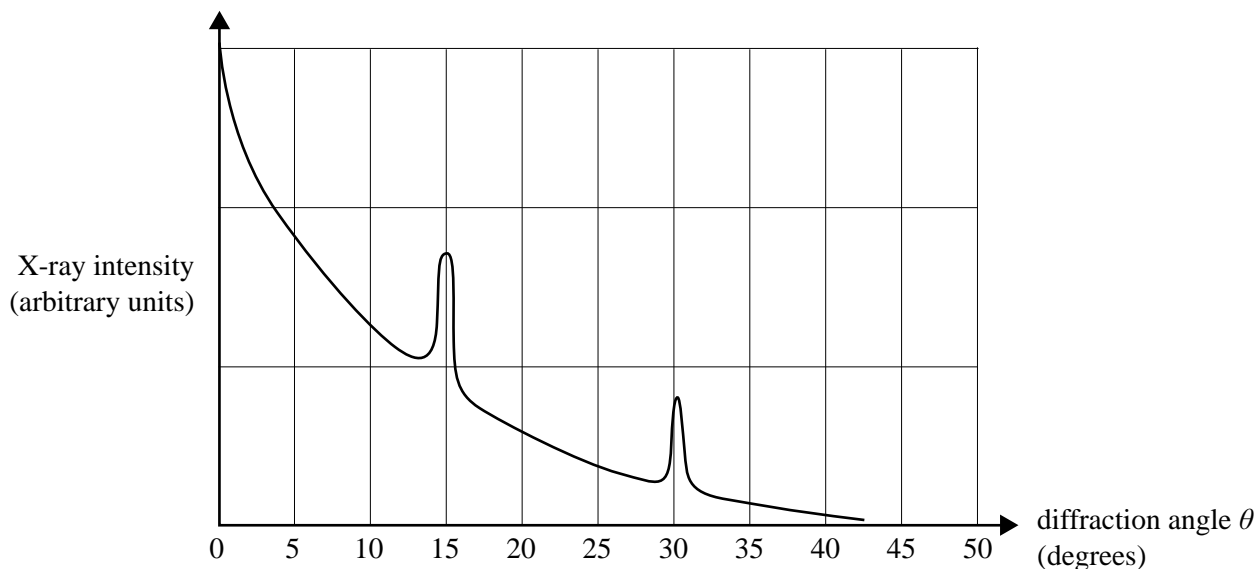

**Figure 1**

**Question 8**

The best estimate of the distance between the planes of atoms in this crystal is

- A.  $5.8 \times 10^{-10}$  m
- B.  $2.9 \times 10^{-10}$  m
- C.  $1.5 \times 10^{-10}$  m
- D.  $1.4 \times 10^{-10}$  m

**Question 9**

The angle  $\theta$  is now increased from  $40^\circ$  to  $90^\circ$ .

How many additional peaks will be seen?

- A. 0
- B. 1
- C. 2
- D. 3

Use the following information to answer Questions 10 and 11.

Synchrotron X-rays with wavelength 0.0709 nm are scattered from an amorphous (non-crystalline) carbon block. For X-rays scattered at a particular angle, the spectrum is shown in Figure 2.

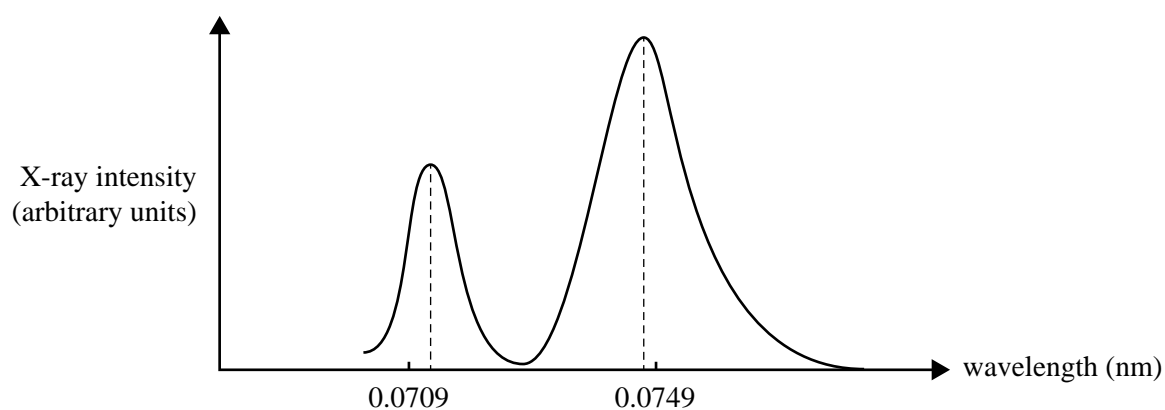

Figure 2

**Question 10**

The peak at wavelength 0.0749 nm is due to

- A. Bragg diffraction by carbon atoms.
- B. Thompson scattering by tightly bound electrons.
- C. Compton scattering by almost-free electrons.
- D. diffuse scattering due to thermal motion of the atoms.

**Question 11**

What energy is transferred to the carbon block when one incoming X-ray photon is scattered, with an outgoing wavelength 0.0749 nm?

- A.  $2.7 \times 10^{-15}$  J
- B.  $2.8 \times 10^{-15}$  J
- C.  $1.5 \times 10^{-16}$  J
- D.  $6.0 \times 10^{-17}$  J

**SECTION B****Instructions for Section B**

Select **one** Detailed study and answer **all** questions within that Detailed study in pencil on the answer sheet provided for multiple-choice questions.

Show the Detailed study you are answering by shading the matching box on your multiple-choice answer sheet and writing the name of the Detailed study in the box provided.

Choose the response that is **correct** for the question.

A correct answer scores 2, an incorrect answer scores 0.

Marks will **not** be deducted for incorrect answers.

No marks will be given if more than one answer is completed for any question.

**Detailed study 5 – Photonics****Question 1**

Which one of the following best describes the light emitted from a semiconductor light-emitting diode (LED)?

- A. coherent light at a single wavelength
- B. incoherent light at a single wavelength
- C. coherent light with wavelengths in a range of several nanometres
- D. incoherent light with wavelengths in a range of several nanometres

**Question 2**

Which one of the following describes how light is produced in an LED?

- A. stimulated transitions of electrons from a lower energy band to an upper energy band
- B. spontaneous transitions of electrons from a lower energy band to an upper energy band
- C. stimulated transitions of electrons from an upper energy band to a lower energy band
- D. spontaneous transitions of electrons from an upper energy band to a lower energy band

**Question 3**

Which one of the following best describes laser light and its production?

- A. Many photons are emitted from different atoms, with the same wavelength but not in phase.
- B. Many photons are emitted from one atom, with photons of the same wavelength and in phase.
- C. Many photons are emitted from different atoms, with photons of the same wavelength and in phase.
- D. Many photons are emitted from different atoms, with photons all with the same direction but not in phase.

**Question 4**

A silica optical fibre has an attenuation versus wavelength curve as shown in Figure 1.

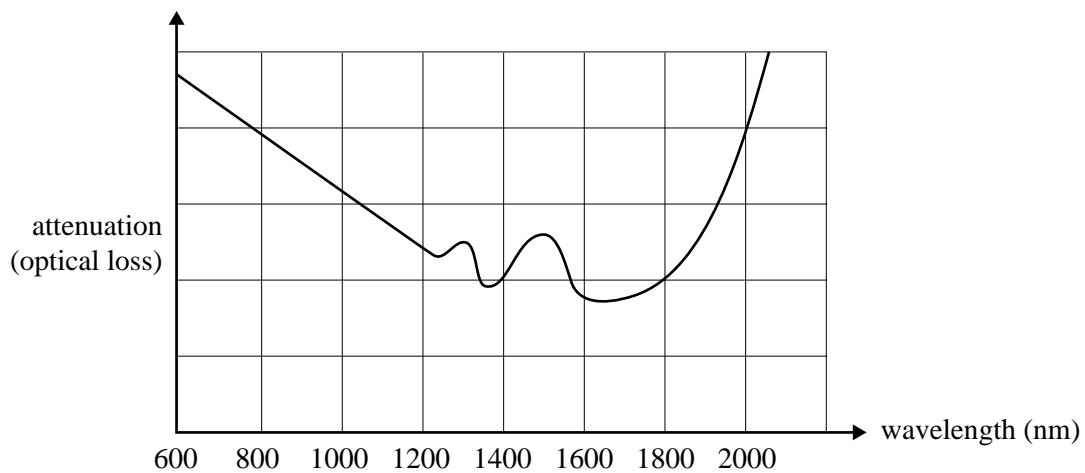

**Figure 1**

The most likely cause of the peaks in the centre of the curve (at 1300 nm and 1500 nm) is

- A. impurities.
- B. Rayleigh scattering.
- C. absorption by silica molecules.
- D. random thermal motion of electrons.



**Question 5**

Light sources A to D have spectra as shown in Figure 2.

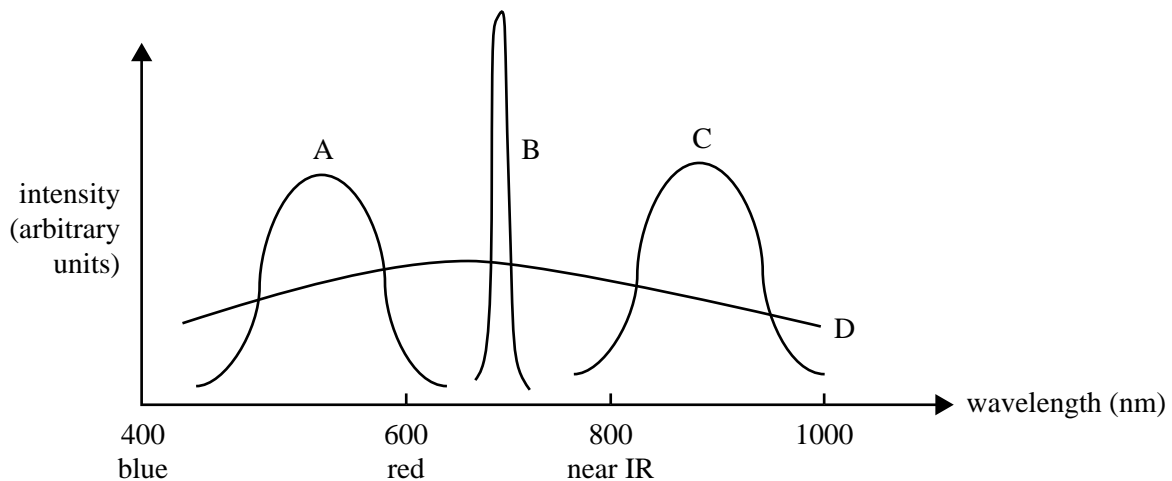

**Figure 2**

Which light source should be used in order to minimise material dispersion in communication signals through an optical fibre?

- A. light source A
- B. light source B
- C. light source C
- D. light source D

**Question 6**

An optical fibre is used to take light produced from a weak light source to a spectrometer. The light source is about 1 cm square and the end of the fibre is about 1 cm from the source.

Which one of the following optical fibres will collect the most light?

- A. an optical fibre with a small diameter and a large acceptance angle
- B. an optical fibre with a large diameter and a large acceptance angle
- C. an optical fibre with a small diameter and a small acceptance angle
- D. an optical fibre with a large diameter and a small acceptance angle

Use the following information to answer Questions 7 and 8.

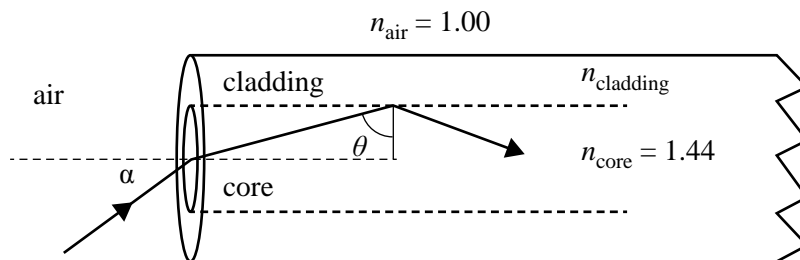

**Figure 3**  
not to scale

**Question 7**

An optical fibre has a refractive index of 1.44 for the core and a critical angle of  $80.0^\circ$  between the core and cladding. This is shown in Figure 3.

Which one of the following is the most likely refractive index of the cladding?

- A. 1.46
- B. 1.42
- C. 1.40
- D. 1.38

**Question 8**

The acceptance angle of this optical fibre in air is closest to

- A.  $14.5^\circ$
- B.  $12.0^\circ$
- C.  $8.5^\circ$
- D.  $7.0^\circ$

**Question 9**

Which one of the following statements best describes a graded-index optical fibre?

- A. The fibre has an outer layer with a constant refractive index that is a little smaller than the refractive index of the core.
- B. The fibre is designed so that as the radial distance from the axis increases, light has a decreasing speed.
- C. The fibre is designed so that the speed of propagation of the light signal in the direction of the axis will be almost the same for rays belonging to different modes.
- D. Graded-index fibres are the only way to overcome material dispersion.

**Question 10**

Long-distance fibre optic communications uses very high-quality silica fibre and a single wavelength to achieve a high rate of data transmission.

Which one of the following describes the type of optical fibre needed for the best result for data transmission?

- A. a single-mode fibre because it has a better material dispersion behaviour
- B. a multi-mode fibre because it can carry several modes simultaneously
- C. a single-mode fibre because a rectangular pulse remains sharp over long distances
- D. a multi-mode fibre because it is less affected by bending than a single-mode fibre

**Question 11**

Students build an optical fibre sensor to detect the presence of a liquid. They use a section of optical fibre that has no cladding. The intensity of light transmitted through the fibre is measured first when there is no liquid present and no light is lost from the sides. It is then measured again when a liquid comes into contact with the fibre, as shown in Figure 4.

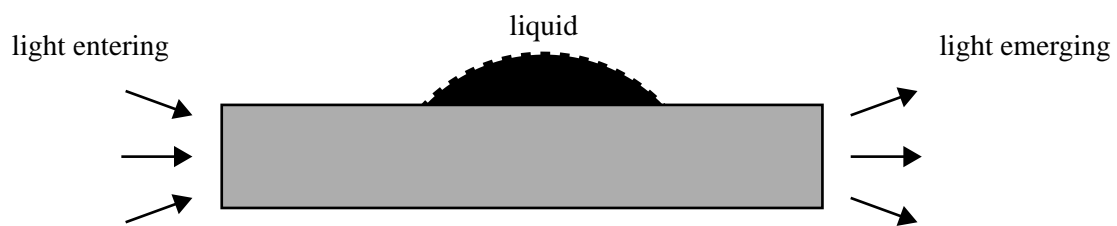

**Figure 4**

As a result of liquid being in contact with the optical fibre, the emerging light intensity

- A. increases if the liquid has a higher refractive index than the fibre.
- B. increases if the liquid has a lower refractive index than the fibre.
- C. does not change as a result of liquid in contact with the fibre.
- D. decreases if the liquid has a higher refractive index than the fibre.

**SECTION B****Instructions for Section B**

Select **one** Detailed study and answer **all** questions within that Detailed study in pencil on the answer sheet provided for multiple-choice questions.

Show the Detailed study you are answering by shading the matching box on your multiple-choice answer sheet and writing the name of the Detailed study in the box provided.

Choose the response that is **correct** for the question.

A correct answer scores 2, an incorrect answer scores 0.

Marks will **not** be deducted for incorrect answers.

No marks will be given if more than one answer is completed for any question.

**Detailed study 6 – Sound****Question 1**

A loudspeaker emits a sound of frequency 30 Hz. The speed of sound in air in these conditions is  $330 \text{ m s}^{-1}$ .

Which one of the following best gives the wavelength of the sound?

- A. 30 m
- B. 11 m
- C. 3.3 m
- D. 0.091 m

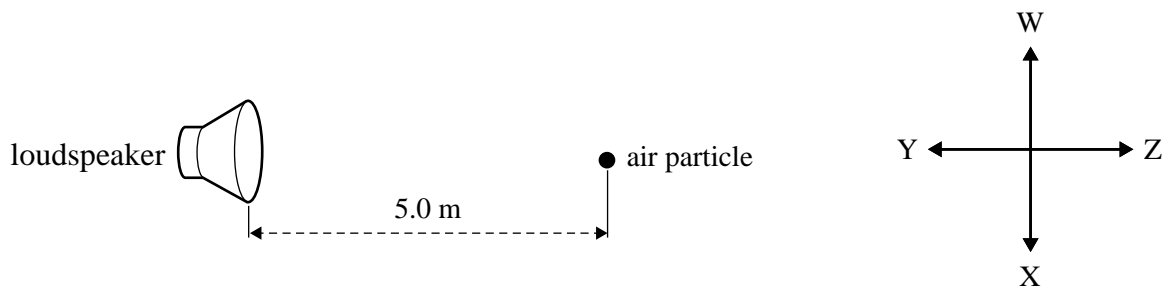
**Question 2****Figure 1**

Consider an air particle initially at rest 5.0 m in front of a loudspeaker, as shown in Figure 1. The speed of sound in air in these conditions is  $330 \text{ m s}^{-1}$ .

Which one of the following best describes the subsequent motion of this particle when the loudspeaker is emitting a sound of frequency 30 Hz?

- A. It moves in direction Z at a constant speed of  $330 \text{ m s}^{-1}$ .
- B. It oscillates about its rest position in direction WX 30 times per second.
- C. It oscillates about its rest position in direction YZ 30 times per second.
- D. It oscillates about its rest position in direction YZ at an average speed of  $330 \text{ m s}^{-1}$ .

*Use the following information to answer Questions 3 and 4.*

A loudspeaker emits a sound of frequency 300 Hz equally in all directions. Emily is standing 4.0 m from the loudspeaker and measures the sound intensity level as 80 dB.

**Question 3**

Which one of the following best gives the sound intensity (in  $\text{W m}^{-2}$ ) at the point where Emily is standing?

- A.  $8.0 \times 10^{-5} \text{ W m}^{-2}$
- B.  $1.0 \times 10^{-4} \text{ W m}^{-2}$
- C.  $8.0 \times 10^{-4} \text{ W m}^{-2}$
- D.  $3.0 \times 10^2 \text{ W m}^{-2}$

**Question 4**

Emily walks away from the loudspeaker until she is 8 m from it.

Which one of the following best gives the sound intensity level (in dB) she will now hear?

- A. 77 dB
- B. 74 dB
- C. 16 dB
- D. 4.0 dB

Use the following information to answer Questions 5 and 6.

Students conduct an experiment to observe standing waves in air columns. They use a hollow tube immersed in water, so the length of the air column in the tube can be varied, as shown in Figure 2.

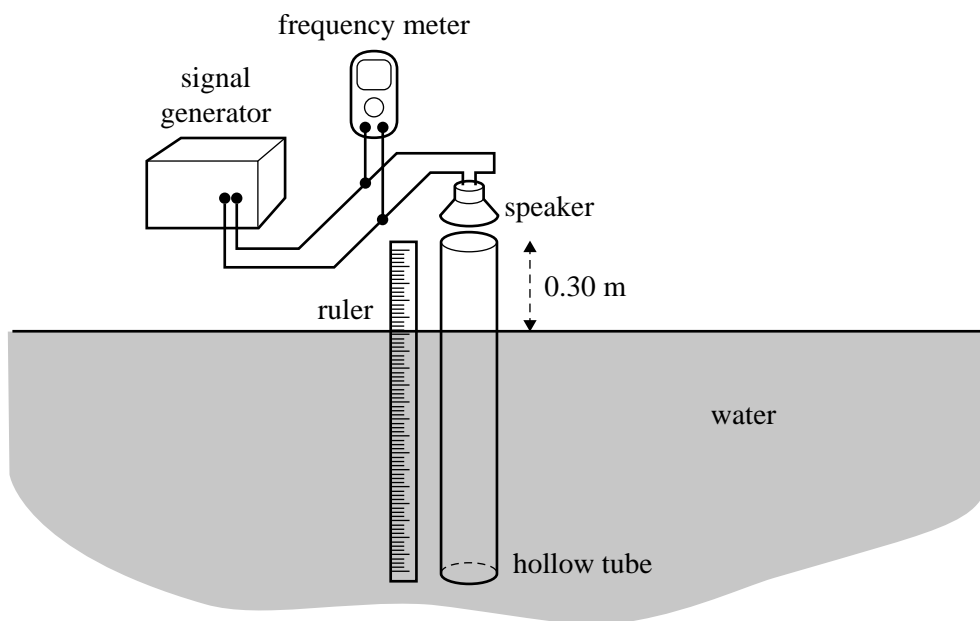

**Figure 2**

The speed of sound in air under the conditions during their experiment is  $320 \text{ m s}^{-1}$ . The end of the tube nearest the speaker acts as an open end and the end of the tube away from the speaker acts as a closed end.

The students set the signal generator to 200 Hz. They begin with the tube at a length of 0.30 m and then raise the tube until they hear the first resonance.

**Question 5**

Which one of the following is the best estimate of the length of the air column at which they hear the first resonance?

- A. 0.40 m
- B. 0.80 m
- C. 1.6 m
- D. 3.2 m

**Question 6**

Which one of the following is the best estimate of the length of the air column at which they hear the next resonance?

- A. 0.40 m
- B. 0.60 m
- C. 1.2 m
- D. 1.6 m

Use the following information to answer Questions 7–9.

Curves of equal phon value are shown in the graph below.

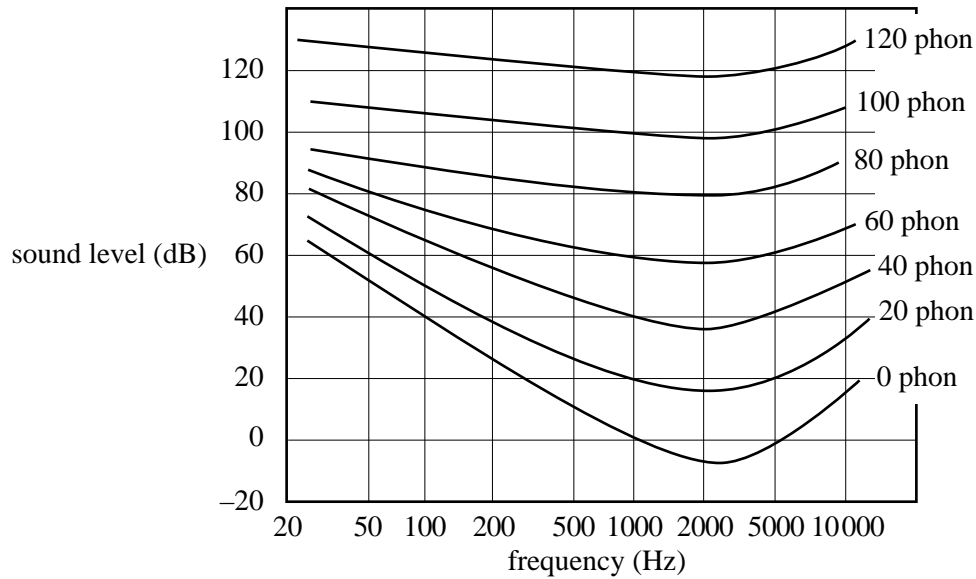

Figure 3

#### Question 7

Richard is listening to sound of frequency 50 Hz. He hears it at a loudness of 60 phon.

Without changing the sound level of the speaker in decibels, the frequency is increased to 2000 Hz.

Which one of the following best gives the loudness at which Richard will now hear the sound?

- A. 100 phon
- B. 80 phon
- C. 52 phon
- D. 40 phon

#### Question 8

Which one of the following statements explains why the phon curves have the shapes shown in Figure 3?

- A. The speed of sound in air is different for different frequencies.
- B. The sensitivity of the human ear increases linearly as the frequency increases.
- C. The frequency sensitivity of the human ear is different to that of many animals.
- D. The sensitivity of the human ear increases until a particular frequency and then decreases again.

#### Question 9

Roger is listening for a distant sound of frequency 100 Hz. He has normal hearing; that is, as in the phon graph. The distant sound is measured by a sound meter as 20 dB.

Which one of the following best describes what Roger will hear?

- A. He will hear it at less than 20 dB.
- B. He will hear it at 20 phon.
- C. He will hear it at 20 dB.
- D. He will not hear it at all.

Use the following information to answer Questions 10 and 11.

A group of students is conducting experiments to study the diffraction of sound.

The first experiment is conducted on the school oval. The arrangement is shown in Figure 4.

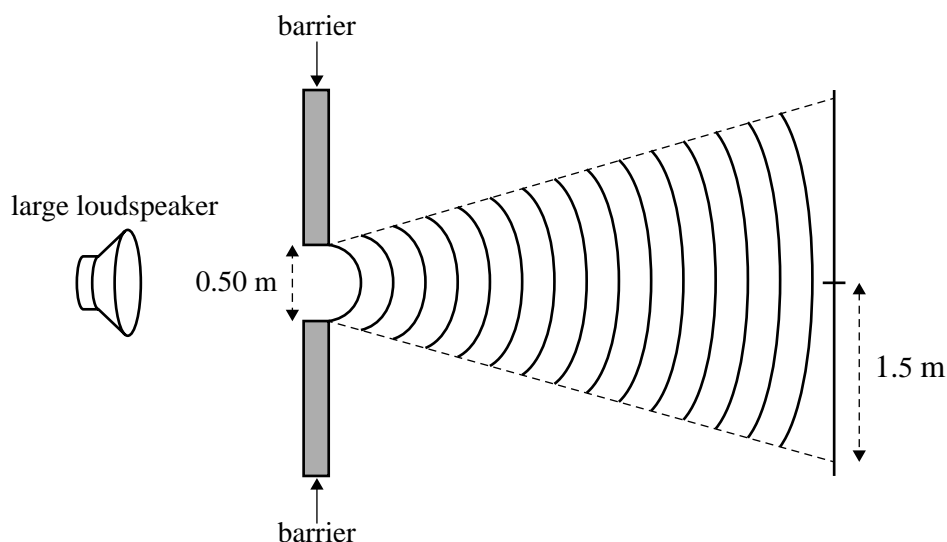

**Figure 4**

The frequency is 1200 Hz. The width of the gap between the two barriers is 0.5 m.

At some distance from the gap, the students note that the edge of the diffraction pattern is 1.5 m off the centre line.

**Question 10**

The students increase the frequency to 3000 Hz.

Which one of the following is most likely to be observed?

- A. The edge of the pattern will still be approximately 1.5 m off the centre line.
- B. The edge of the pattern will be closer to the centre line.
- C. The edge of the pattern will be further out than 1.5 m.
- D. There will now be no edge of the pattern.

**Question 11**

The students now repeat the experiment in their classroom, but do not observe such a clear edge to the pattern.

Which one of the following is the most likely reason for this?

- A. The room is too big for the wavelength.
- B. The room is too small for the wavelength.
- C. The doorway allowed a proportion of the sound to escape and so destructive interference did not occur completely.
- D. Reflection off the walls and ceiling of the classroom meant that destructive interference did not occur completely.



**Victorian Certificate of Education  
2015**

**PHYSICS**

**Written examination**

**Wednesday 11 November 2015**

**Reading time: 2.00 pm to 2.15 pm (15 minutes)**

**Writing time: 2.15 pm to 4.45 pm (2 hours 30 minutes)**

**FORMULA SHEET**

**Instructions**

- A question and answer book is provided with this formula sheet.

**Students are NOT permitted to bring mobile phones and/or any other unauthorised electronic devices into the examination room.**

1	velocity; acceleration	$v = \frac{\Delta x}{\Delta t}; \quad a = \frac{\Delta v}{\Delta t}$
2	equations for constant acceleration	$v = u + at$ $x = ut + \frac{1}{2}at^2$ $v^2 = u^2 + 2ax$ $x = \frac{1}{2}(v + u)t$
3	Newton's second law	$\Sigma F = ma$
4	circular motion	$a = \frac{v^2}{r} = \frac{4\pi^2 r}{T^2}$
5	Hooke's law	$F = -kx$
6	elastic potential energy	$\frac{1}{2}kx^2$
7	gravitational potential energy near the surface of Earth	$mgh$
8	kinetic energy	$\frac{1}{2}mv^2$
9	Newton's law of universal gravitation	$F = G \frac{M_1 M_2}{r^2}$
10	gravitational field	$g = G \frac{M}{r^2}$
11	acceleration due to gravity at Earth's surface	$g = 10 \text{ m s}^{-2}$
12	voltage; power	$V = RI \quad P = VI = I^2 R$
13	resistors in series	$R_T = R_1 + R_2$
14	resistors in parallel	$\frac{1}{R_T} = \frac{1}{R_1} + \frac{1}{R_2}$
15	transformer action	$\frac{V_1}{V_2} = \frac{N_1}{N_2}$
16	AC voltage and current	$V_{\text{RMS}} = \frac{1}{\sqrt{2}} V_{\text{peak}} \quad I_{\text{RMS}} = \frac{1}{\sqrt{2}} I_{\text{peak}}$
17	magnetic force	$F = I l B$

18	electromagnetic induction	emf: $\varepsilon = -N \frac{\Delta\Phi}{\Delta t}$ flux: $\Phi = BA$
19	transmission losses	$V_{\text{drop}} = I_{\text{line}} R_{\text{line}}$ $P_{\text{loss}} = I_{\text{line}}^2 R_{\text{line}}$
20	mass of the electron	$m_e = 9.1 \times 10^{-31} \text{ kg}$
21	charge on the electron	$e = -1.6 \times 10^{-19} \text{ C}$
22	Planck's constant	$h = 6.63 \times 10^{-34} \text{ J s}$ $h = 4.14 \times 10^{-15} \text{ eV s}$
23	speed of light	$c = 3.0 \times 10^8 \text{ m s}^{-1}$
24	photoelectric effect	$E_{K\text{max}} = hf - W$
25	photon energy	$E = hf$
26	photon momentum	$p = \frac{h}{\lambda}$
27	de Broglie wavelength	$\lambda = \frac{h}{p}$
28	speed, frequency and wavelength	$v = f\lambda$
29	energy transformations for electrons in an electron gun (<100 keV)	$\frac{1}{2}mv^2 = eV$
30	radius of electron path	$r = \frac{mv}{eB}$
31	magnetic force on a moving electron	$F = evB$
32	Bragg's law	$n\lambda = 2d\sin\theta$
33	electric field between charged plates	$E = \frac{V}{d}$
34	band gap energy	$E = \frac{hc}{\lambda}$
35	Snell's law	$n_1 \sin\theta_1 = n_2 \sin\theta_2$
36	intensity and level	sound intensity level (in dB) $L(\text{dB}) = 10\log_{10}\left(\frac{I}{I_0}\right)$ where $I_0 = 1.0 \times 10^{-12} \text{ W m}^{-2}$

37	Lorentz factor	$\gamma = \frac{1}{\sqrt{1 - \frac{v^2}{c^2}}}$
38	time dilation	$t = t_0 \gamma$
39	length contraction	$L = \frac{L_0}{\gamma}$
40	relativistic mass	$m = m_0 \gamma$
41	total energy	$E_{\text{total}} = E_k + E_{\text{rest}} = mc^2$
42	stress	$\sigma = \frac{F}{A}$
43	strain	$\varepsilon = \frac{\Delta L}{L}$
44	Young's modulus	$E = \frac{\text{stress}}{\text{strain}}$
45	capacitors	time constant : $\tau = RC$
46	universal gravitational constant	$G = 6.67 \times 10^{-11} \text{ N m}^2 \text{ kg}^{-2}$
47	mass of Earth	$M_E = 5.98 \times 10^{24} \text{ kg}$
48	radius of Earth	$R_E = 6.37 \times 10^6 \text{ m}$
49	mass of the electron	$m_e = 9.1 \times 10^{-31} \text{ kg}$
50	charge on the electron	$e = -1.6 \times 10^{-19} \text{ C}$
51	speed of light	$c = 3.0 \times 10^8 \text{ m s}^{-1}$

**Prefixes/Units**

p = pico =  $10^{-12}$

n = nano =  $10^{-9}$

$\mu$  = micro =  $10^{-6}$

m = milli =  $10^{-3}$

k = kilo =  $10^3$

M = mega =  $10^6$

G = giga =  $10^9$

t = tonne =  $10^3 \text{ kg}$

**END OF FORMULA SHEET**