

Trial Examination 2011

VCE Physics Unit 3

Written Examination

Question and Answer Booklet

Reading time: 15 minutes

Writing time: 1 hour 30 minutes

Student's Name: _____

Teacher's Name: _____

Structure of Booklet

Section	Number of questions	Number of questions to be answered	Number of marks
A Core – Areas of study			
1. Motion in one and two dimensions	16	16	40
2. Electronics and photonics	13	13	26
B Detailed studies			
1. Einstein's special relativity OR	12	12	24
2. Materials and their use in structures OR	12	12	24
3. Further electronics	12	12	24
			Total 90

Students are permitted to bring into the examination room: pens, pencils, highlighters, erasers, sharpeners, rulers, up to two pages (one A4 sheet) of pre-written notes (typed or handwritten) and one scientific calculator.

Students are NOT permitted to bring into the examination room: blank pieces of paper and/or white out liquid/tape.

Materials supplied

Question and answer booklet of 31 pages with a detachable data sheet in the centrefold.

Answer sheet for multiple-choice questions.

Instructions

Detach the data sheet from the centre of this booklet during reading time.

Please ensure that you write your **name** and your **teacher's name** in the space provided on this booklet and on the answer sheet for multiple-choice questions.

Unless otherwise indicated, the diagrams in this book are **not** drawn to scale.

All written responses must be in English.

Students are NOT permitted to bring mobile phones and/or any other unauthorised electronic devices into the examination room.

Students are advised that this is a trial examination only and cannot in any way guarantee the content or the format of the 2011 VCE Physics Unit 3 Written Examination.

Neap Trial Exams are licensed to be photocopied or placed on the school intranet and used only within the confines of the school purchasing them, for the purpose of examining that school's students only. They may not be otherwise reproduced or distributed. The copyright of Neap Trial Exams remains with Neap. No Neap Trial Exam or any part thereof is to be issued or passed on by any person to any party inclusive of other schools, non-practising teachers, coaching colleges, tutors, parents, students, publishing agencies or websites without the express written consent of Neap.

SECTION A – CORE

Instructions for Section A

Answer **all** questions **for both** Areas of study in this section of the paper.

Where an answer box has a unit printed in it, give your answer in that unit.

You should take the value of g to be 10 m s^{-2} .

In questions where more than one mark is available, appropriate working should be shown.

Areas of study	Page
Motion in one and two dimensions	3
Electronics and photonics	11

Area of study 1 – Motion in one and two dimensions

A 2.0 kg remote control car is acted on by a **constant driving force** as it travels a distance of 10.0 m. It accelerates from rest and reaches a constant speed after travelling 5.0 m in a straight line.

The graph in Figure 1 shows the total **frictional forces** acting on the remote control car.

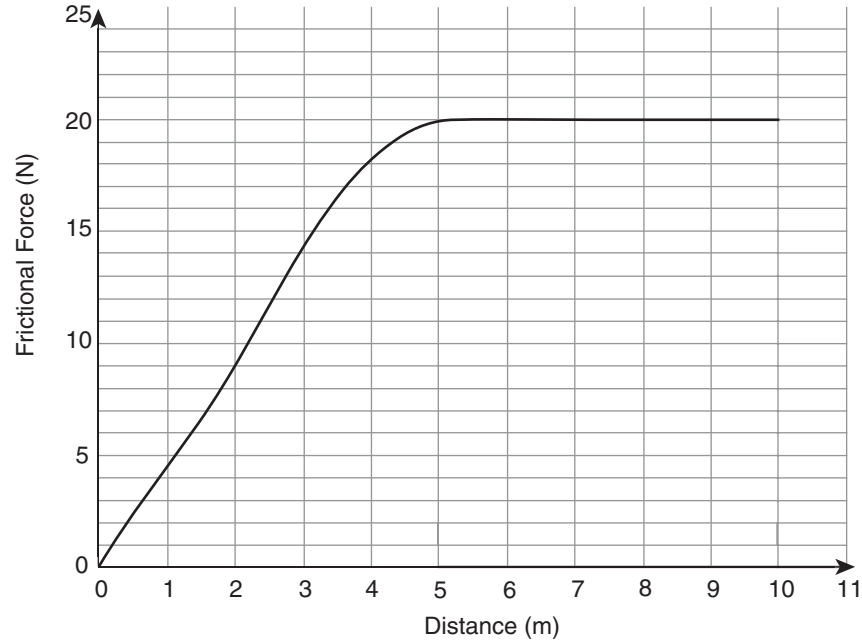

Figure 1

Question 1

Calculate the acceleration of the car when it is 2.0 m from its starting position.

ms^{-2}

3 marks

Question 2

Calculate the speed of the car when it has travelled 5.0 m.

ms^{-1}

3 marks

The remote control car continues at this speed and is steered so that it travels in a circular path of radius 0.8 m, as shown in Figure 2.

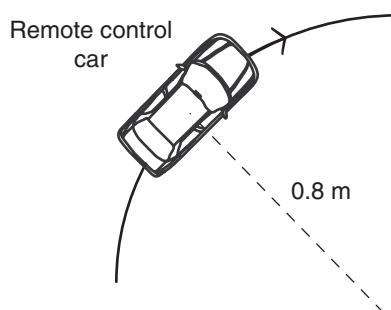
**Figure 2****Question 3**

On the diagram in Figure 2, indicate the direction of the net force acting on the remote control car when it is in the position shown.

1 mark

Question 4

If the maximum sideways frictional force that can act between the tyres of the remote control car and the surface it is moving on is equal to 4.5 N, calculate the maximum speed at which the remote control car can travel and continue in a circular path of this radius.

ms^{-1}

2 marks

Question 5

Explain why this maximum possible speed would be greater than the value calculated in Question 4 if the remote control car was travelling around a ‘banked’ (sloped) circular track of the same radius, rather than on a flat surface.

3 marks

The remote control car (mass 2.0 kg) now once again travels in a straight line. Matilda, who is controlling the car, has constructed a ‘speed hump’ which is an arc of a circle of radius 1.5 m, as shown in Figure 3.

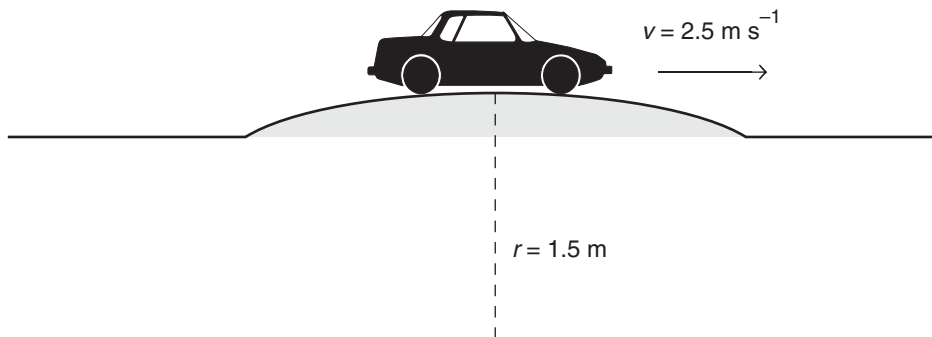
**Figure 3**

When the car reaches the top of the speed hump, it is travelling at 2.5 ms^{-1} .

Question 6

Calculate the apparent weight of the remote control car when it is on top of the speed hump.

N

2 marks

The remote control car is still travelling at 2.5 m s^{-1} in an easterly direction when it collides with a stationary model monster truck. Immediately after the collision, the monster truck is travelling 1.0 m s^{-1} east and the remote control car travels 1.2 m s^{-1} west. The collision takes 0.05 seconds.

Question 7

Calculate the mass of the model monster truck.

kg

2 marks

Question 8

Calculate the magnitude and direction of the force exerted by the monster truck on the remote control car.

Magnitude:	N
------------	---

Direction of force:

3 marks

Question 9

Matilda, the owner of the remote control car, states that as the car and the monster truck bounced off each other and travelled in opposite directions, the collision is elastic. Is she correct? Explain your answer and use calculations to support your explanation.

3 marks

Matilda now builds a ramp which makes an angle of 37° with the horizontal. She launches the remote control car from the top of the ramp with a speed of 2.0 m s^{-1} . The car lands on the ground 0.43 seconds after it leaves the ramp.

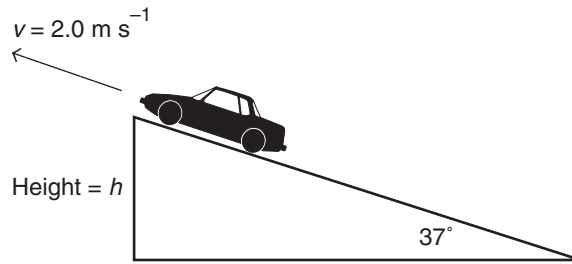

Figure 4

Question 10

Calculate the horizontal distance that the car lands from the base of the ramp.

2 marks

Question 11

Calculate the maximum height **above the ramp** reached by the remote control car.

2 marks

Question 12

Calculate the height of the ramp (shown as h in Figure 4).

m

3 marks

After all this activity the battery for the remote control car begins to flatten so Matilda decides to recharge it. She places it in a battery holder, where it is held in place by a light spring.

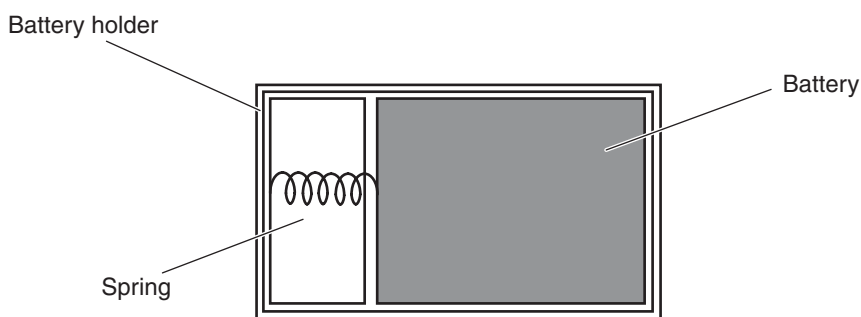
**Figure 5**

The battery has a mass of 300 g and the force vs extension graph for the spring is shown in Figure 6. When the battery is inserted into the holder, the compression of the spring is 0.5 cm.

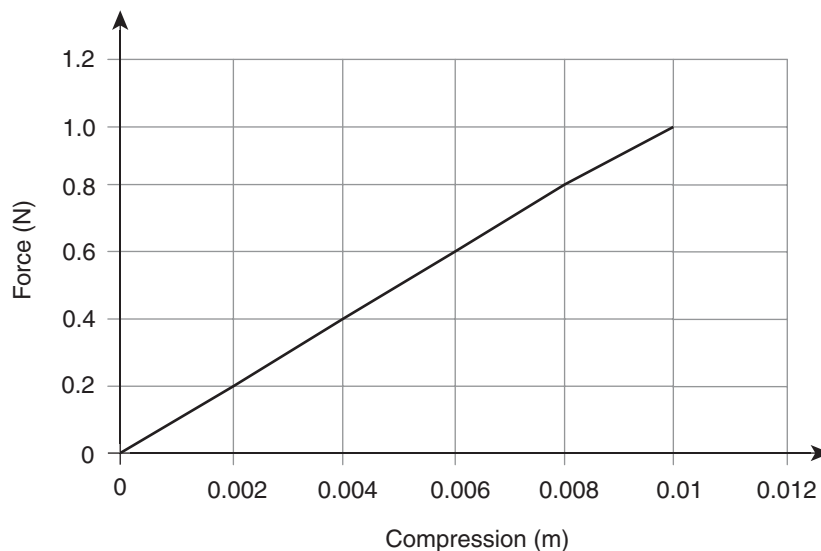
**Figure 6**

Once the battery is charged, Matilda attempts to remove the battery from the charger but inadvertently flicks the battery from the charger, so that it is launched vertically into the air by the spring in the battery holder.

Question 13

Calculate the speed at which the battery leaves the charger.

m s^{-1}

3 marks

The following information relates to Questions 14 and 15.

A communications satellite of mass 2.0×10^5 kg orbits the Earth with a period of 2.0 hours.

Question 14

Calculate the **altitude** of the satellite above the Earth's surface. Give your answer in kilometres.

km

4 marks

Question 15

Calculate the apparent weight of the satellite when it is in this orbit.

2 marks

The graph in Figure 7 shows the relationship between the gravitational force acting on a 1.0 kg object (F_g) and its distance from the centre of a small planet (r).

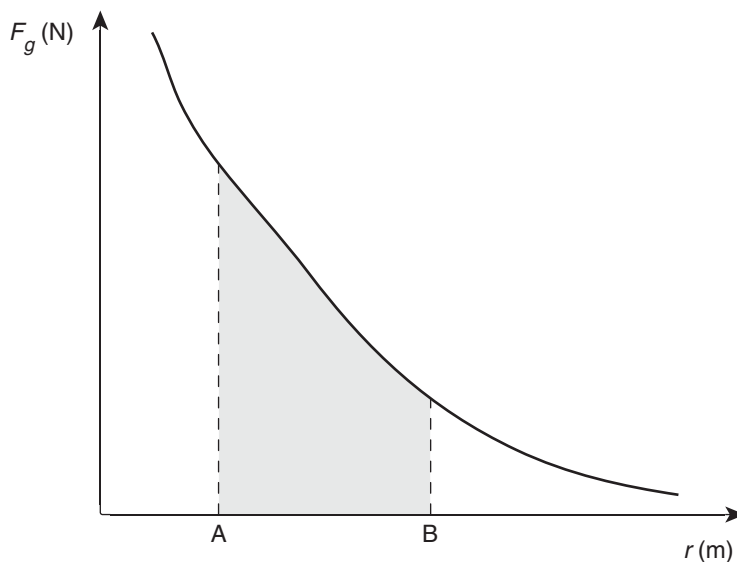
**Figure 7****Question 16**

Which of the following quantities is represented by the shaded area under the graph in Figure 7?

- A. The decrease in kinetic energy as the object moves from position A to position B.
- B. The decrease in gravitational potential energy as the object moves from position A to position B.
- C. The difference in gravitational field strength between position A and position B.
- D. The decrease in the object weight as it moves from position A to position B.

2 marks

END OF AREA OF STUDY 1

Area of study 2 – Electronics and photonics

The diagram below (Figure 1) shows an LED in an electrical circuit. The LED is placed in series with both an ammeter (A) and a resistor (R). The purpose of the ammeter is to read the current going through the series circuit.

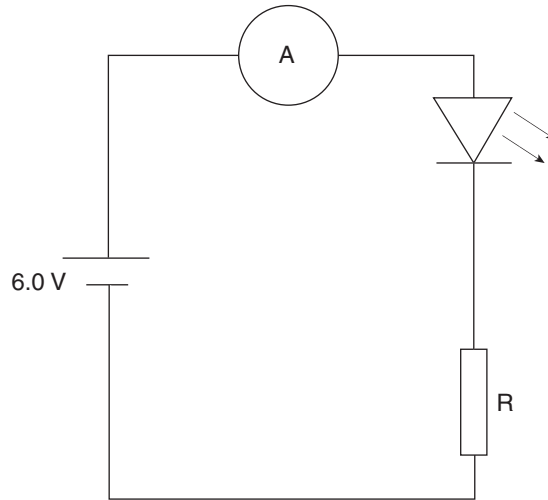
**Figure 1****Question 1**

Explain why the ammeter is connected in series with the LED and the resistor R, and is **not connected** in parallel with the LED and resistor R as shown in Figure 2.

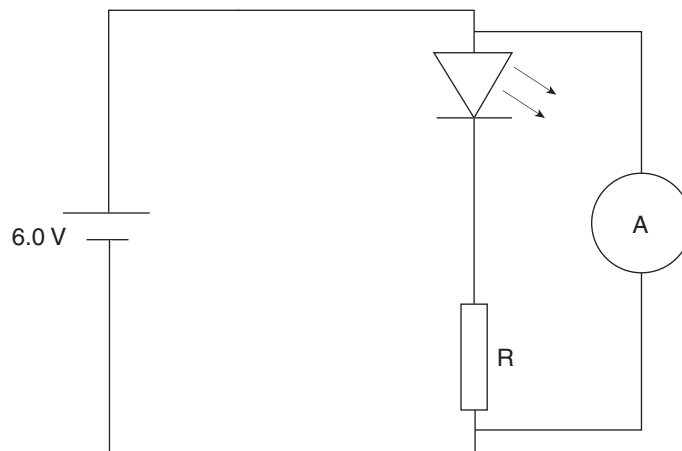
**Figure 2**

2 marks

The characteristic graph for the LED is shown in Figure 3 below.

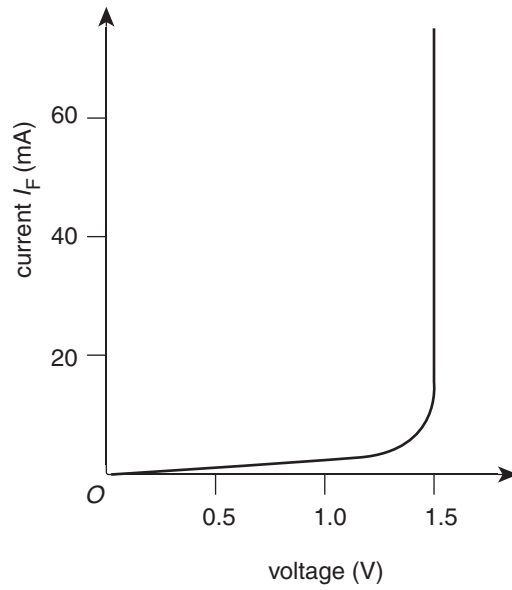

Figure 3

Question 2

Calculate the current through the LED if the value of R is 300Ω . Show your working.

mA

2 marks

Question 3

The LED is now reversed in the circuit. What is the current through the LED now?

Explain your answer.

2 marks

The diagram below (Figure 4) shows the characteristic resistance–light intensity graph for a LDR used in a factory for controlling the factory illumination.

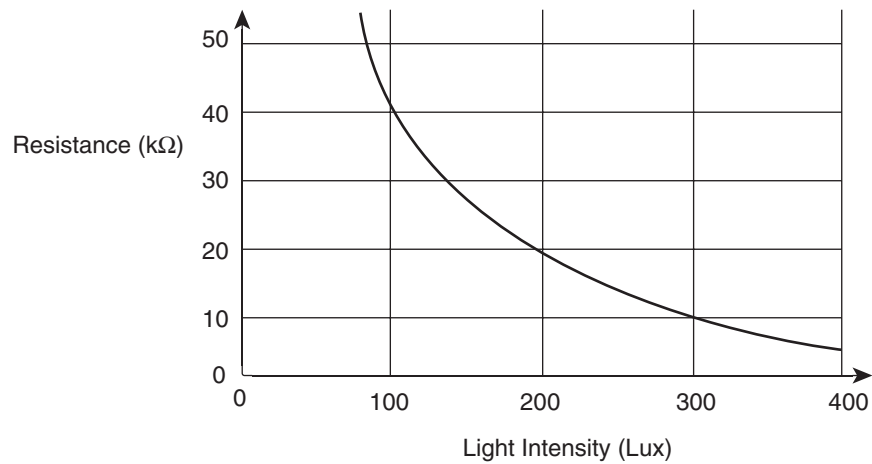

Figure 4

Question 4

What is the value of the resistance of the LDR when the light intensity is 100 Lux?

1 mark

Part of the control circuit for the factory illumination unit is shown in Figure 5 below. The variable resistor is set by the manufacturer at 20 kΩ and the supply voltage is 18V. If the external light level goes down to 100 Lux, then the factory lights turn on.

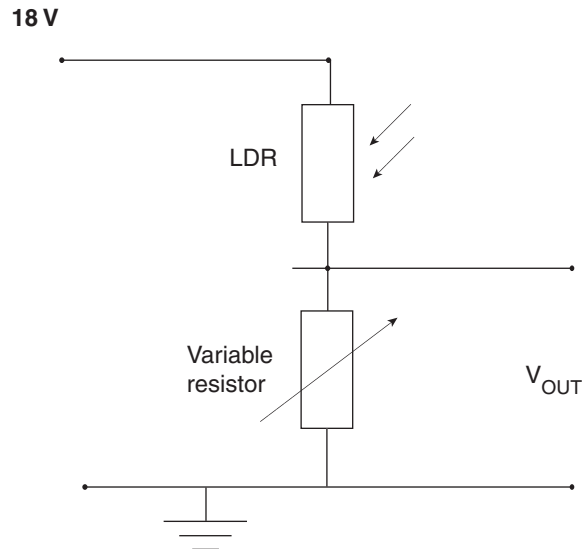

Figure 5

Question 5

Calculate the value of V_{OUT} when the sun is shining and the light intensity is 300 Lux. Show your working.

2 marks

Question 6

Explain what happens to the output voltage V_{OUT} when the sun stops shining, clouds come over and the light intensity decreases to 100 Lux. Use calculations to support your answer. Explain how this output voltage V_{OUT} can be used to illuminate the factory.

3 marks

The following information relates to Questions 7 to 9.

Figure 6 shows the output voltage versus input voltage for an amplifier.

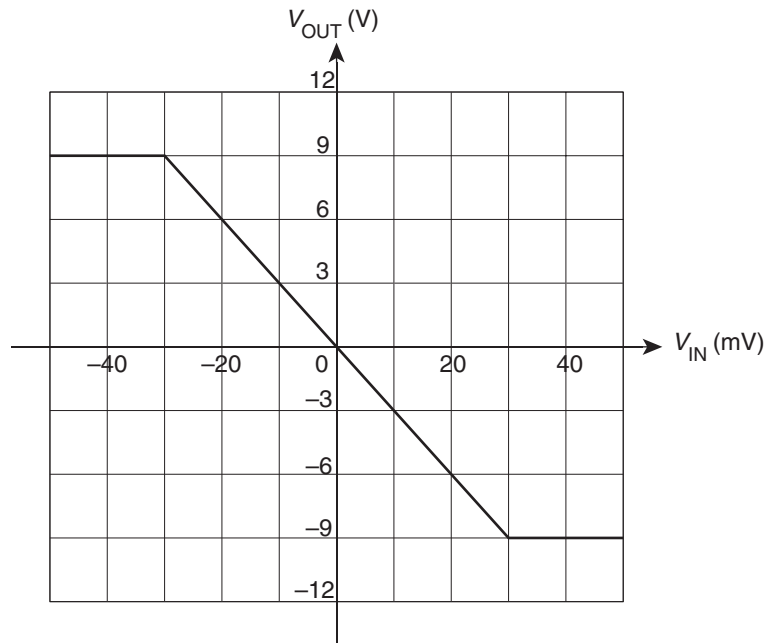

Figure 6

Question 7

Calculate the gain of the amplifier. Show your working.

2 marks

Question 8

Is the amplifier an inverting amplifier or a non-inverting amplifier?

1 mark

Question 9

Explain what clipping means in reference to amplifiers, specify the input voltage ranges which would be clipped for the amplifier shown in Figure 6 and detail the implications for input signals which are clipped.

3 marks

Question 10

Explain concisely what the process of amplitude modulation is. Use a diagram in your answer.

2 marks

Two resistors are connected to a 12.0 V battery as shown in Figure 7.

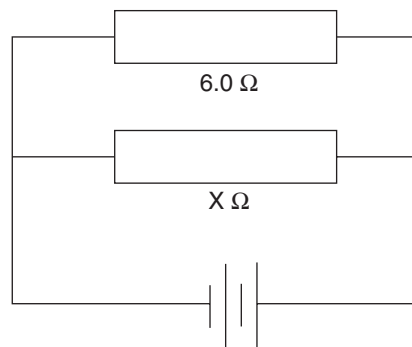

Figure 7

The total equivalent resistance of the two resistors is 4.0Ω .



Trial Examination 2011

VCE Physics Unit 3

Written Examination

Data Sheet

Detach this data sheet before commencing the examination.

This data sheet is provided for your reference.

Physics Unit 3 Data Sheet

1	velocity; acceleration	$v = \frac{\Delta x}{\Delta t}; a = \frac{\Delta v}{\Delta t}$
2	equations for constant acceleration	$v = u + at$ $x = ut + \frac{1}{2}at^2$ $v^2 = u^2 + 2ax$ $x = \frac{1}{2}(v + u)t$
3	Newton's second law	$F = ma$
4	circular motion	$a = \frac{v^2}{r} = \frac{4\pi^2 r}{T^2}$
5	Hooke's law	$F = -kx$
6	elastic potential energy	$\frac{1}{2}kx^2$
7	gravitational potential energy near the surface of the Earth	mgh
8	kinetic energy	$\frac{1}{2}mv^2$
9	Newton's law of universal gravitation	$F = G \frac{M_1 M_2}{r^2}$
10	gravitational field	$g = G \frac{M}{r^2}$
11	stress	$\sigma = \frac{F}{A}$
12	strain	$\varepsilon = \frac{\Delta L}{L}$

13	Young's modulus	$E = \frac{\text{stress}}{\text{strain}}$
14	transformer action	$\frac{V_1}{V_2} = \frac{N_1}{N_2}$
15	AC voltage and current	$V_{\text{RMS}} = \frac{1}{2\sqrt{2}} V_{\text{p-p}}; I_{\text{RMS}} = \frac{1}{2\sqrt{2}} I_{\text{p-p}}$
16	voltage; power	$V = RI; P = VI = I^2 R$
17	resistors in series	$R_T = R_1 + R_2$
18	resistors in parallel	$\frac{1}{R_T} = \frac{1}{R_1} + \frac{1}{R_2}$
19	capacitors	time constant: $\tau = RC$
20	Lorentz factor	$\gamma = \frac{1}{\sqrt{1 - \frac{v^2}{c^2}}}$
21	time dilation	$t = t_0 \gamma$
22	length contraction	$L = \frac{L_0}{\gamma}$
23	relativistic mass	$m = m_0 \gamma$
24	Total energy	$E_{\text{total}} = E_k + E_{\text{rest}} = mc^2$
25	universal gravitational constant	$G = 6.67 \times 10^{-11} \text{ N m}^2 \text{ kg}^{-2}$

26	mass of Earth	$M_E = 5.98 \times 10^{24} \text{ kg}$
27	radius of Earth	$R_E = 6.37 \times 10^6 \text{ m}$
28	mass of the electron	$m_e = 9.1 \times 10^{-31} \text{ kg}$
29	charge on the electron	$e = -1.6 \times 10^{-19} \text{ C}$
30	speed of light	$c = 3.0 \times 10^8 \text{ m s}^{-1}$

Prefixes/Units

$$p = \text{pico} = 10^{-12}$$

$$n = \text{nano} = 10^{-9}$$

$$\mu = \text{micro} = 10^{-6}$$

$$m = \text{milli} = 10^{-3}$$

$$k = \text{kilo} = 10^3$$

$$M = \text{mega} = 10^6$$

$$G = \text{giga} = 10^9$$

$$t = \text{tonne} = 10^3 \text{ kg}$$

END OF DATA SHEET

Question 11

Calculate the resistance of resistor X. Show your working.

2 marks

Question 12

Calculate the power dissipated by resistor X. Show your working.

2 marks

The resistor X is replaced with one that has twice as much resistance $2X$ as shown in Figure 8.

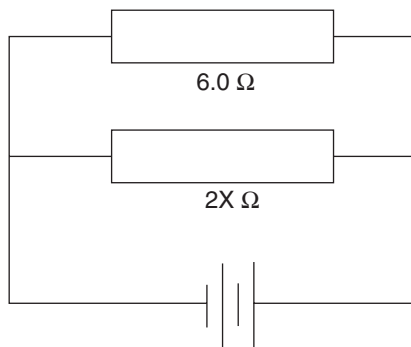
**Figure 8****Question 13**

The power dissipated by the resistor $2X$ in Figure 8 compared to the resistor X in Figure 14 will be

- A. halved.
- B. the same.
- C. doubled.
- D. can not be determined from the information given.

2 marks

END OF AREA OF STUDY 2

SECTION B – DETAILED STUDIES

Instructions for Section B

Choose **one** of the following **Detailed studies**.

Answer **all** the questions on the Detailed study you have chosen.

Answer **all** questions in pencil on the answer sheet provided for multiple-choice questions.

Choose the response that is **correct** or that **best answers** the question.

A correct answer scores 2, an incorrect answer scores 0.

Marks will **not** be deducted for incorrect answers.

No marks will be given if more than one answer is completed for any question.

You should take the value of g to be 10 m s^{-2} .

Detailed study	Page
Detailed study 1: Einstein’s special relativity	19
Detailed study 2: Materials and their use in structures	22
Detailed study 3: Further electronics	27

Detailed study 1 – Einstein’s special relativity**Question 1**

Which of the following is best described as an inertial reference frame?

- A. the earth at the equator
- B. a student riding a roller coaster
- C. a car travelling around a corner at constant speed
- D. a spacecraft travelling at constant velocity in outer space

Question 2

A spacecraft travels past a stationary observer on the moon at a speed of $0.85c$. The γ factor is closest to

- A. 0
- B. 1.0
- C. 1.9
- D. 2.2

Question 3

Which one of the following is a postulate of Einstein’s relativity?

- A. The speed of light depends on the observer.
- B. Physics can identify a state of absolute rest.
- C. Time and space are absolute.
- D. The speed of light is constant.

Question 4

Which of the following does not relate to Einstein’s concept that mass can be converted to energy?

- A. a hydrogen bomb
- B. burning coal
- C. a nuclear reactor
- D. the sun

Question 5

The Michelson–Morley Experiment of 1887 determined

- A. c is constant
- B. γ is constant everywhere
- C. c is constantly changing everywhere
- D. None of the above

Question 6

Proper time is best described as

- A. the time recorded in the reference frame moving with respect to the event.
- B. correct time.
- C. relativistic time.
- D. the time recorded in the reference frame at rest with respect to the event.

Question 7

An electron is accelerated using an 800 MeV accelerator. The mass increase for this electron is

- A. 1.42×10^{-25} kg
- B. 1.42×10^{-26} kg
- C. 1.42×10^{-27} kg
- D. 1.42×10^{-28} kg

Question 8

A satellite is travelling at 1.0×10^4 m s⁻¹ in its orbit around the earth. Which one of the following statements explains this situation best regarding time dilation?

- A. Newtonian physics is a very poor approximation to using Einstein's physics.
- B. Newtonian physics is a very good approximation to using Einstein's physics.
- C. The time dilation factor would be large.
- D. None of the above

Question 9

An electron is injected into a final accelerator at 0.98c. Both the electron's speed and its energy increase until it is travelling much closer to the speed of light.

Which of the following best describes the effect of the accelerator on the electron's speed and its energy?

- A. Both the speed and the energy increase slightly.
 - B. Only the energy increases slightly.
 - C. The speed increases slightly whilst the energy increases substantially.
 - D. Both the speed and the energy increase substantially.
-

A spacecraft passes an earth-based observer with a relative speed near the speed of light, such that the γ factor is 2. The pilot of the spacecraft measures the length of the spacecraft as 80 m.

Question 10

Which of the following best gives the length of the spacecraft as observed from earth?

- A. 40 m
- B. 80 m
- C. 120 m
- D. 160 m

It takes the pilot 30 s to make a journey as seen on his clock.

Question 11

Which of the following best gives the time as observed by the earth-based observer?

- A. 15s
 - B. 30s
 - C. 45s
 - D. 60s
-

Question 12

James Clerk Maxwell in 1864 produced equations which demonstrated that

- A. the aether exists.
- B. perpendicular magnetic and electric waves can travel at $3.0 \times 10^8 \text{ m s}^{-1}$.
- C. that the aether slows down the speed at which light travels.
- D. None of the above.

END OF DETAILED STUDY 1

Detailed study 2 – Materials and their use in structures

The stress vs strain graph for two new composite materials being tested, material X and material Y, are shown in Figure 1 below for both compression and tension. The graph for material X is shown by the solid line and the graph for the material Y is shown by the dashed line.

Material X : _____

Material Y : - - - - -

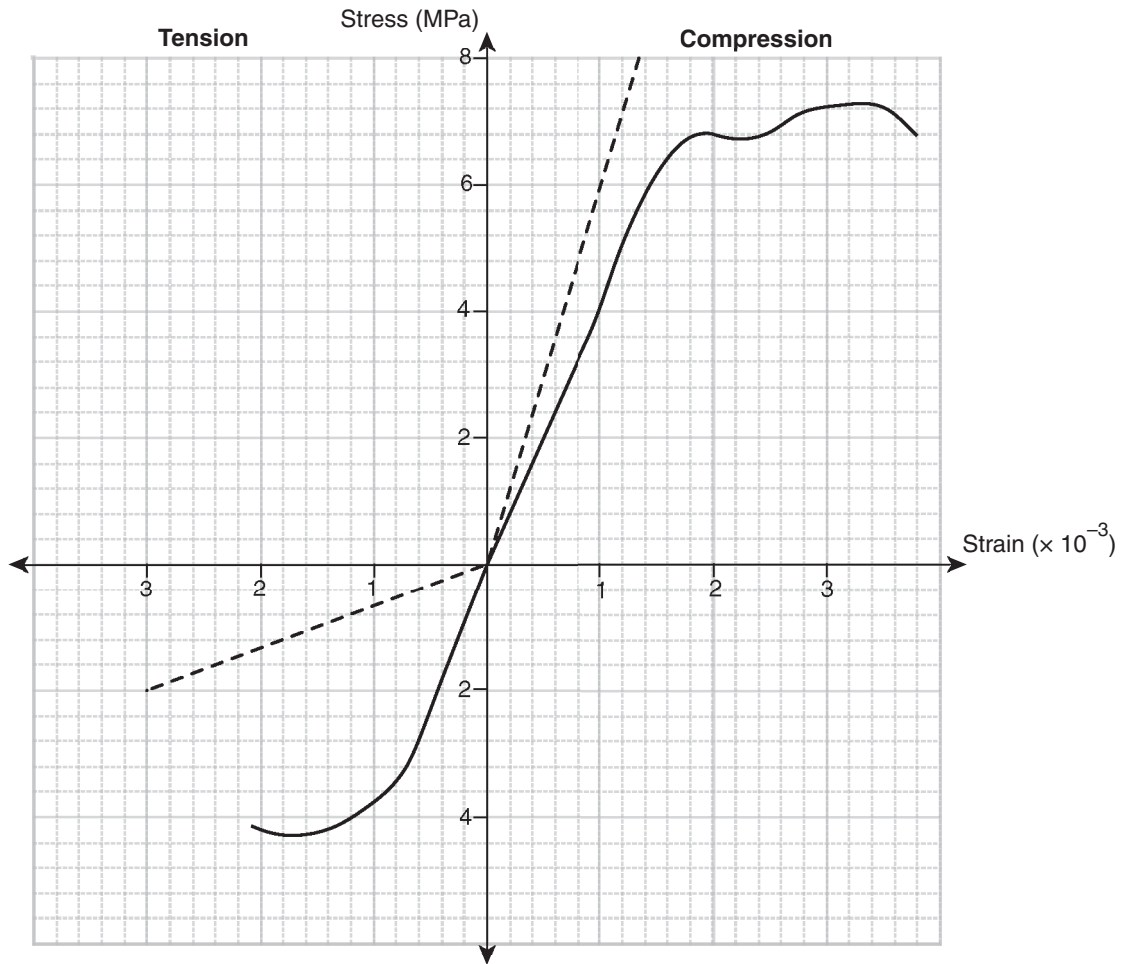

Figure 1

Question 1

Which of the following statements is correct?

- A. Material X is stronger than Y in compression but weaker than Y in tension.
- B. Material X is tougher than material Y both in tension and compression.
- C. Material X is stiffer than material Y both in tension and compression.
- D. Material X is brittle in compression but ductile in tension.

Question 2

The value of Young's Modulus for material *Y* when it is in tension is equal to

- A. $2.0 \times 10^{-9} \text{ N m}^{-2}$.
- B. $2.0 \times 10^6 \text{ N m}^{-2}$.
- C. $6.7 \times 10^8 \text{ N m}^{-2}$.
- D. $4.0 \times 10^9 \text{ N m}^{-2}$.

Question 3

The tensile strength of material *Y* is equal to

- A. $2.0 \times 10^{-3} \text{ N}$.
- B. $2.0 \times 10^6 \text{ N}$.
- C. $8.0 \times 10^6 \text{ N}$.
- D. $6.7 \times 10^8 \text{ N}$.

A compressive force of 2100 N is applied to a cylindrical rod of material *X* with radius 1.0 cm and length 1.2 m.

Question 4

The stress in the rod of material *X* is equal to

- A. 0.66 N m^{-2} .
- B. $0.67 \times 10^{-2} \text{ N m}^{-2}$.
- C. $6.6 \times 10^3 \text{ N m}^{-2}$.
- D. $6.7 \times 10^6 \text{ N m}^{-2}$.

Question 5

When the force described above is applied to the rod of material *X*, the rod will

- A. not fracture, and return to its original length when the force is removed.
- B. not fracture, but it will not return to its original length when the force is removed.
- C. fracture.
- D. the behaviour of the rod cannot be predicted from the information supplied.

A mass of 200 kg is suspended from a 1.0 m length of wire constructed of material *Y*, causing the wire to extend by 1.2 mm.

Question 6

The radius of the wire is equal to

- A. $8.0 \times 10^{-4} \text{ m}$.
- B. $1.2 \times 10^{-3} \text{ m}$.
- C. $8.9 \times 10^{-3} \text{ m}$.
- D. $2.8 \times 10^{-2} \text{ m}$.

Question 7

Which of the following would be the toughest material?

- A. Material X under compression
- B. Material X under tension
- C. Material Y under compression
- D. Material Y under tension

A cylinder constructed from material Y, with a cross-sectional area of 0.1 m^2 and height 5.0 m , is subjected to a compressive force of $6.0 \times 10^5 \text{ N}$.

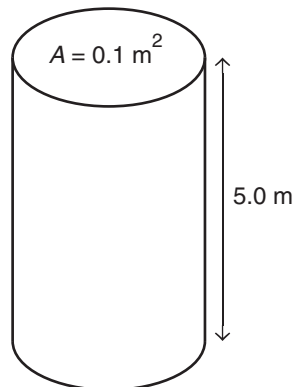

Figure 2

Question 8

The energy stored in the cylinder is equal to

- A. $3.0 \times 10^2 \text{ J}$.
- B. $1.5 \times 10^3 \text{ J}$.
- C. $3.0 \times 10^3 \text{ J}$.
- D. $6.0 \times 10^6 \text{ J}$.

A concrete viewing platform is constructed at a scenic lookout as shown in Figure 3 below.

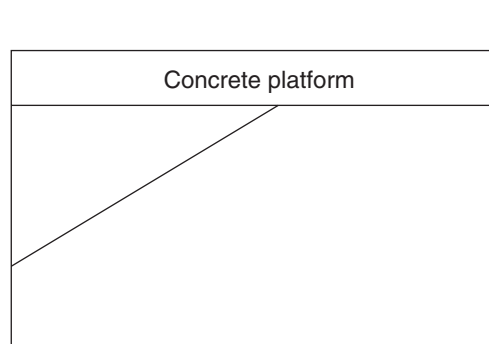
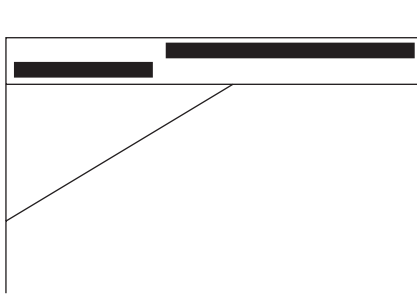
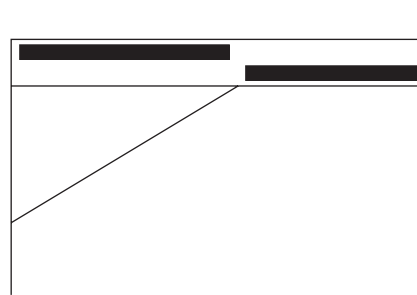
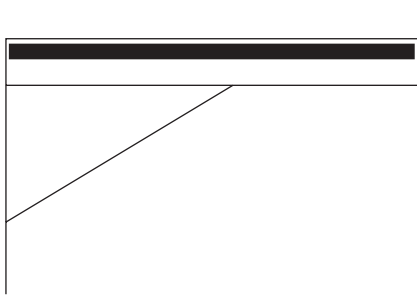
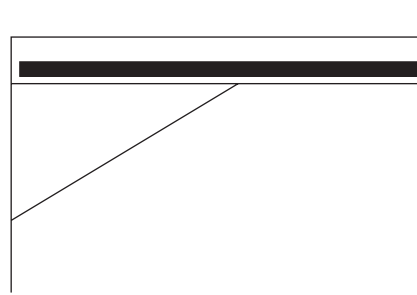

Figure 3

Steel rods are placed in the concrete to reinforce it in regions of weakness.

Question 9

Which of the following diagrams show the appropriate positions that the steel rods should be placed to correctly reinforce the concrete platform?

A.**B.****C.****D.**

The following information relates to Questions 10 and 11.

A 50 kg sign outside a shop is suspended from two identical cables as shown in Figure 4. Each cable makes an angle of θ° with the horizontal edge of the sign.

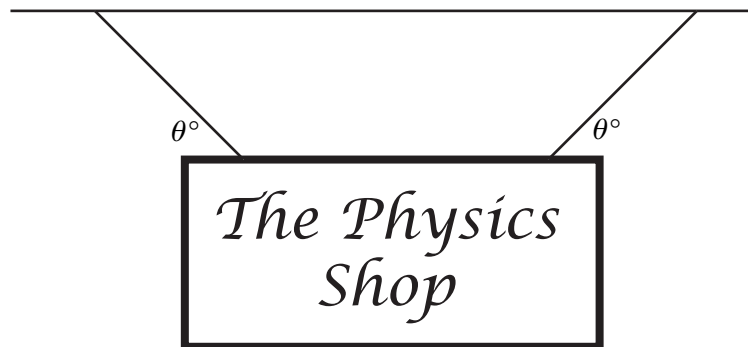
**Figure 4**

The tension in each of the cables is equal to 590 N.

Question 10

The magnitude of the angle θ is equal to

- A.** 2.0° .
- B.** 25° .
- C.** 58° .
- D.** 68° .

Instead of the cables being of equal length as in Figure 4, the sign is hung incorrectly as shown in Figure 5, so that cable 1 is longer than cable 2 and hence angle θ_1 is less than angle θ_2 .

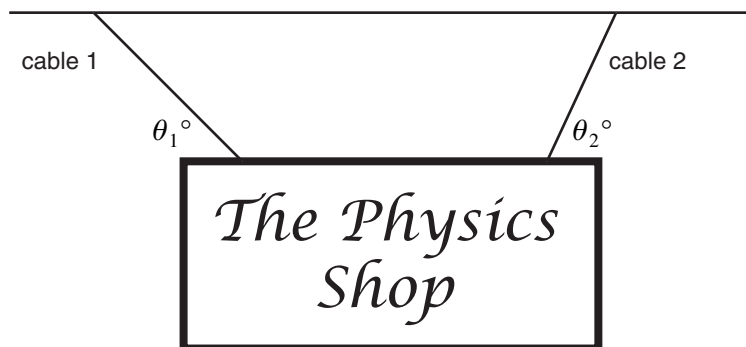

Figure 5

Question 11

Which of the following statements is correct?

- A. The tension in cable 1 is greater than the tension in cable 2.
- B. The tension in cable 1 is less than the tension in cable 2.
- C. The tension in cable 1 will be the same as the tension in cable 2.
- D. It would be impossible to suspend the sign as shown in Figure 5.

A piece of playground equipment is constructed of a 3.0 m plank of wood with mass 100 kg, suspended from two chains as shown in Figure 6. Each chain is connected to a point 0.2 m from each end of the plank, and the chains are both vertical.

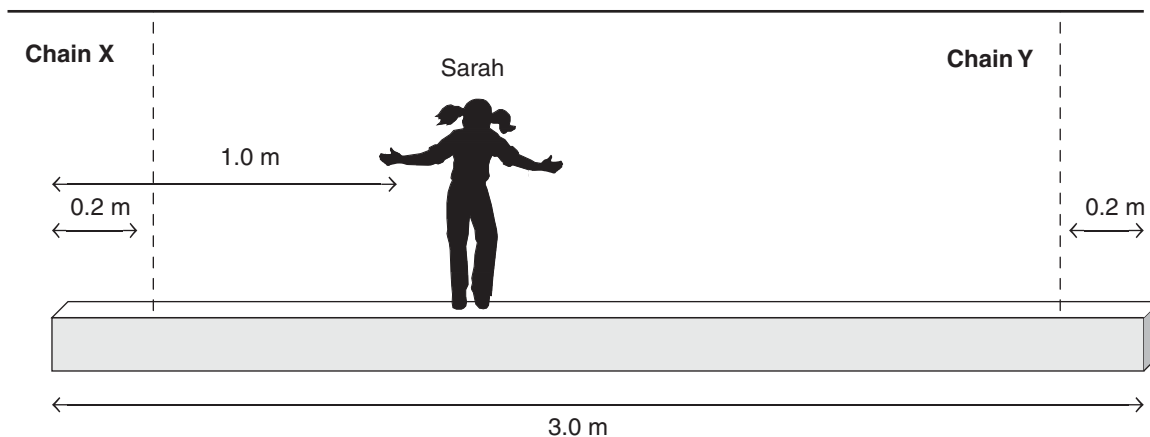

Figure 6

Sarah, who has a mass of 20 kg, stands on the plank 1.0 m from the left end.

Question 12

The tension in chain Y is equal to

- A. 56.1 N.
- B. 61.5 N.
- C. 300 N.
- D. 562 N.

END OF DETAILED STUDY 2

Detailed study 3 – Further electronics

The following information relates to Questions 1 to 4.

The transformer shown in Figure 1 below transforms 240 VAC RMS into 24 VAC RMS. For the purposes of these questions, assume that the transformer is ideal.

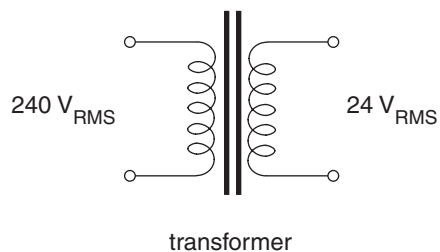

Figure 1

Question 1

The peak to peak output voltage, V_{p-p} , for this transformer is given by

- A. $\frac{24}{\sqrt{2}}\text{ V}$
- B. 24 V
- C. $24\sqrt{2}\text{ V}$
- D. $48\sqrt{2}\text{ V}$

Question 2

The ratio of turns in the secondary coils compared to the primary coils of the transformer is

- A. 1:10.
- B. 5:1.
- C. 10:1.
- D. 14:1.

The output power (P_S) of the transformer is 24 W.

Question 3

The current in the primary coils of the transformer is

- A. 0.05 A.
- B. 0.1 A.
- C. 0.5 A.
- D. 1.0 A.

Question 4

If the transformer was **not** ideal, we could expect

- A. $P_S < P_P$.
- B. $P_S = P_P$.
- C. $P_S > P_P$.
- D. this cannot be determined from the information given.

A type of bridge rectification circuit is shown in Figure 2.

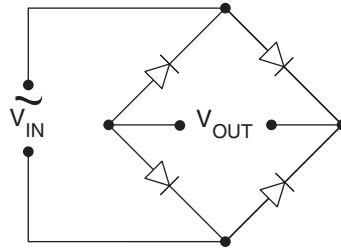

Figure 2

Question 5

The bridge rectification circuit shown in Figure 2 is best described as

- A. a quarter-wave rectifier.
- B. a half-wave rectifier.
- C. a three-quarter wave rectifier.
- D. a full-wave rectifier.

The type of diode used has a 1.0 V drop in forward bias as shown in Figure 3.

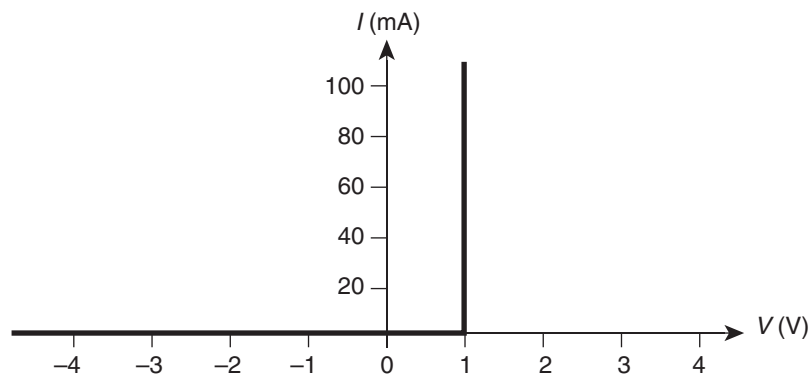

Figure 3

Question 6

If the peak input voltage is 20 V, the peak output voltage of the bridge rectifier circuit is

- A. 14 V.
- B. 18 V.
- C. 19 V.
- D. 20 V.

Question 7

Which of the following best represents the output voltage on a CRO?

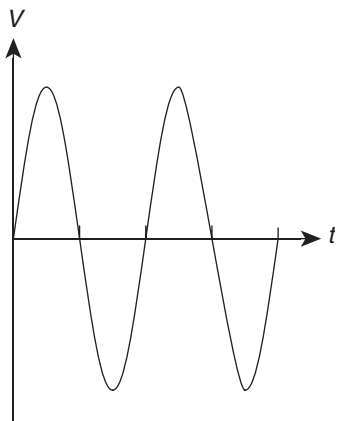
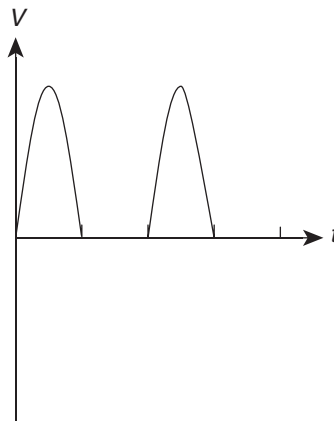
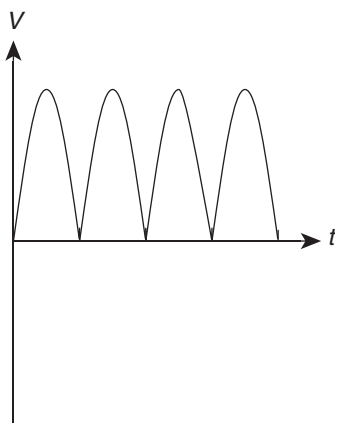
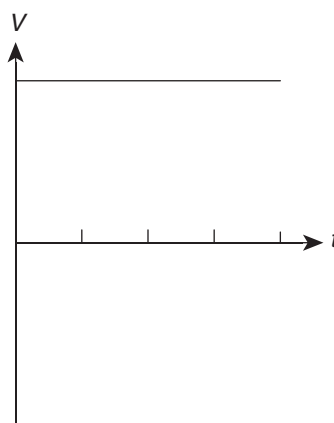
A.**B.****C.****D.**

A $20\ \mu\text{F}$ capacitor (C) is placed in parallel with a $10\ \text{k}\Omega$ load resistor (R) at V_{OUT} .

Question 8

The time constant for the RC circuit is

- A.** 0.02 s.
- B.** 0.2 s.
- C.** 2.0 s.
- D.** 20 s.

Question 9

The output voltage needs to be smoothed further. This is best achieved by making

- A.** C smaller and R the same.
- B.** C larger and R the same.
- C.** C smaller and R smaller.
- D.** C the same and R smaller.

Zener diodes are often used in electronics circuits. Figure 4 shows the characteristic graph for one type of Zener diode.

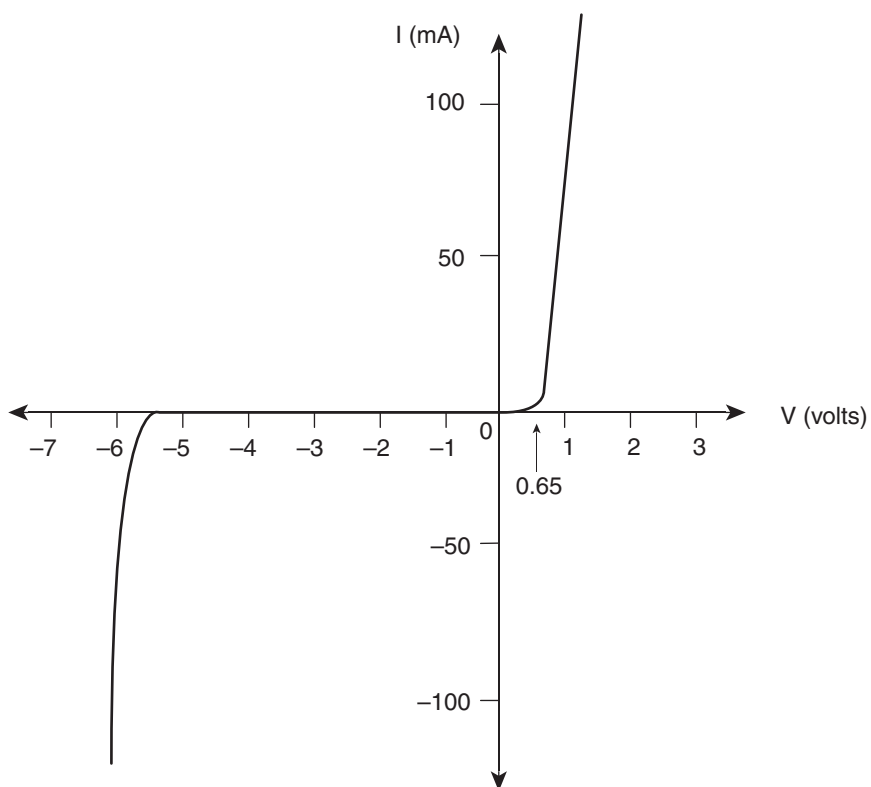

Figure 4

Question 10

A Zener diode is used in an electronic circuit

- A. as a voltage regulator by using the Zener diode in forward bias.
- B. as a voltage regulator by using the Zener diode in reverse bias.
- C. as a voltage regulator by using the Zener diode in either forward bias or reverse bias.
- D. as a voltage regulator by using the Zener diode only when it has +100 mA.

Question 11

If the Zener diode shown in Figure 4 is used as a voltage regulator the magnitude of the voltage output will be closest to

- A. 0.0 V.
- B. 0.65 V.
- C. 1.0 V.
- D. 6.0 V.

One common design feature on a voltage regulators are radiator fins.

Question 12

The purpose of the radiator fins is to

- A. shield the voltage regulator from outside heat.
- B. trap the heat of the voltage regulator.
- C. radiate excess heat away from the voltage regulator.
- D. use the heat of the voltage regulator to run a fan.

END OF QUESTION AND ANSWER BOOKLET