



INSIGHT

Trial Exam Paper

2010

PHYSICS

Written examination 1

Worked Solutions

This book presents:

- worked solutions, giving you a series of points to show you how to work through the questions
- mark allocation details.

This trial examination produced by Insight Publications is NOT an official VCAA paper for 2010 Physics written examination 1. This examination paper is licensed to be printed, photocopied or placed on the school intranet and used only within the confines of the purchasing school for examining their students. No trial examination or part thereof may be issued or passed on to any other party including other schools, practising or non-practising teachers, tutors, parents, websites or publishing agencies without the written consent of Insight Publications.

SECTION A – Core

Area of study 1 – Motion in one and two dimensions

The following information relates to Questions 1 and 2.

A container full of sand is pulled up an incline by a cable, as shown in Figure 1. The combined mass of the container and sand is 1400 kg.

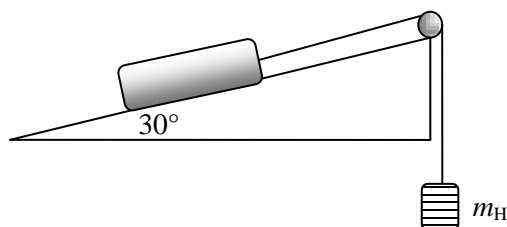

Figure 1

Question 1

If the cable suddenly broke, what would be the magnitude of the acceleration of the container down the incline?

Worked solution

Acceleration down the incline, $a = g \sin \theta = 10 \sin 30^\circ = 5 \text{ m s}^{-2}$.

5 m s^{-2}

2 marks

Mark allocation

- 1 mark for the correct expression to calculate acceleration.
- 1 mark for correct answer.

Tips

- *The magnitude of acceleration down an inclined slope due to an object's weight will be less than acceleration due to gravity, g .*
- *Resolve components of vectors in the direction of motion and perpendicular to it.*

Question 2

When the hanging mass, m_H , is 800 kg the full container is found to move at a constant speed. What is the force of friction acting on the container?

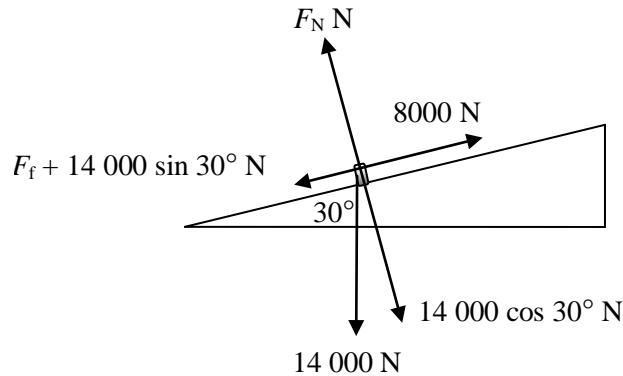
Worked solution

The force of friction is $8000 - 14\,000 \sin 30^\circ = 1000$

1000 N

2 marks

Mark allocation

- 1 mark for finding net force and equating it to zero.
- 1 mark for correctly finding force of friction from net force.

Tips

- *Find components in the direction of motion and perpendicular to it.*
- *Draw a force diagram when finding net force.*

Question 3

If the hanging mass, m_H , is increased to 1000 kg and the friction force stays the same, what is the magnitude of the container's acceleration now?

Worked solution

$$\Sigma F = ma$$

$$10\,000 - (1000 + 7000) = 1400a$$

Therefore, $a = 1.43 \text{ m s}^{-2}$.

1.43 m s^{-2}

2 marks

SECTION A – Area of study 1 – continued
TURN OVER

Mark allocation

- 1 mark for finding net force and equating it to $= ma$.
- 1 mark for correctly calculating acceleration from $F = ma$.
- 2 marks consequential for using (wrong) friction force from previous question, *and* everything else is correct.

Tips

- *Acceleration is the net force per mass. Find the net force to calculate acceleration.*
- *Use appropriate signs for vector quantities.*

The following information relates to Questions 4 to 6.

Bruce pushes two blocks, B₁ and B₂, with a force of 45 N. As a result, the two blocks move together along a floor to the right, as shown in Figure 2. The blocks have a mass of 16 kg and 8 kg, respectively, and they encounter constant friction force of 7 N and 3 N, respectively.

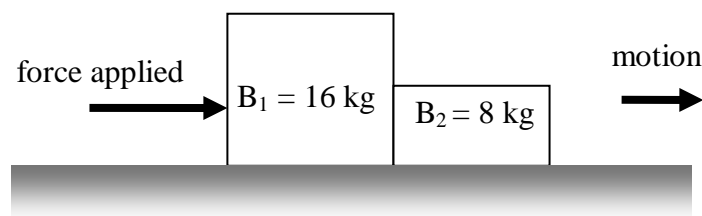

Figure 2

Question 4

What is the magnitude of the acceleration of block B₁?

Worked solution

$$\text{Acceleration} = \frac{\Sigma F}{m} = \frac{45 - 10}{16 + 8} = 1.46 \text{ m s}^{-2}$$

1.46 m s ⁻²

2 marks

Mark allocation

- 1 mark for correctly using acceleration = net force ÷ mass.
- 1 mark for correct answer.

Question 5

What is the magnitude of the force exerted by B₁ on B₂? Show your working.

Worked solution

Examine forces on B₂:

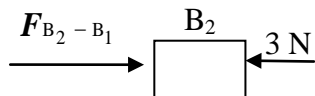

$$\Sigma F = ma$$

$F_{B_2 - B_1} - 3 = 8 \times 1.46$, where $F_{B_2 - B_1}$ is the force on B₂ by B₁.

Therefore, $F_{B_2 - B_1} = (8 \times 1.46) + 3 = 14.7 \text{ N}$

14.7 N

2 marks

Mark allocation

- 1 mark for correct balance of forces.
- 1 mark for correct answer.
- 2 marks consequential if (wrong) value of acceleration used from previous question and all else is correct.
- 1 mark if Newton's third law is stated as an explanation but no other working is shown.

Question 6

What is the force magnitude of the force exerted by B₂ on B₁? Show your working.

Worked solution

Examine forces on B₁:

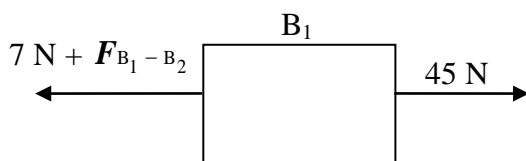

$$\Sigma F = ma$$

$$45 - 7 - F_{B_1 - B_2} = 16 \times 1.46$$

Therefore, $F_{B_1 - B_2} = 14.7 \text{ N}$, which is equal and opposite to $F_{B_2 - B_1}$, as expected in accordance with Newton's second law of motion.

14.7 N

2 marks

SECTION A – Area of study 1 – continued
TURN OVER

Mark allocation

- 1 mark for correct balance of forces.
- 1 mark for correct answer.

Tips

- *A force diagram is useful when looking at force on one part of a structure, which may be isolated in this analysis from the rest of the structure.*
- *The two masses are moving together and hence have the same acceleration. The force on one by the other is in accordance with Newton's third law of motion.*
- *Remember to use vector addition when analysing net force.*

The following information relates to Questions 7 and 8.

Figure 3 shows a bike rider going around a banked surface in uniform circular motion in a radius of 5.0 m. The combined mass of the bike and the rider is 135 kg and the angle of the bank is 15.0° .

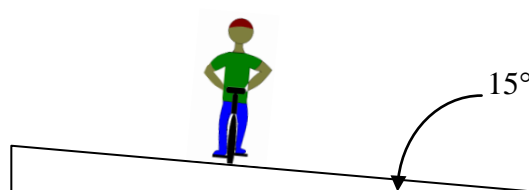

Figure 3

Question 7

On Figure 3, draw an arrow to show the direction of net force on the rider.

Worked solution

The arrow is shown in the figure. Since the rider is in uniform circular motion, the centripetal force will be towards the centre of the circle.

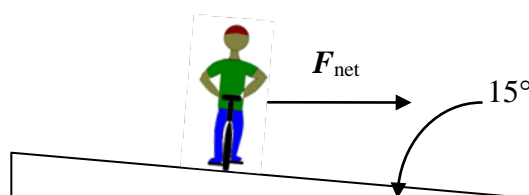

1 mark

Mark allocation

- 1 mark for correct direction of arrow.
- No mark for two arrows, a line with no direction or ambiguous direction.

Question 8

What is the maximum safe speed of the rider, without taking into account any contributing effects of friction?

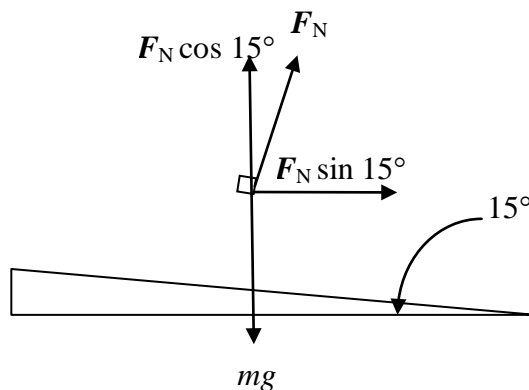
Worked solution

$$F_N \sin 15^\circ = \frac{mv^2}{r}$$

$$F_N \cos 15^\circ = mg$$

Therefore, $\tan 15^\circ = \frac{v^2}{rg}$, and $v = \sqrt{rg \tan 15^\circ} = 3.66 \text{ m s}^{-1}$

3.66 m s ⁻¹

3 marks

Mark allocation

- 1 mark for deriving/stating the correct expression for speed in terms of angle and radius.
- 1 mark for substituting correct values for radius and angle.
- 1 mark for correct calculation of speed.

Question 9

What is the magnitude of the net force acting on the combined bike and rider?

Worked solution

$$F_{\text{net}} = \frac{mv^2}{r} = 362 \text{ N}$$

362 N

2 marks

SECTION A – Area of study 1 – continued
TURN OVER

Mark allocation

- 1 mark for equating net force to $\frac{mv^2}{r}$.
- 1 mark for correct answer.

Tips

- Remember that in Newtonian physics, all objects are treated as a point located at the centre of mass. This will help in visualising the circular path of the rider and the direction of the centripetal force.
- In uniform circular motion, the net (vector) sum of all forces must be towards the centre of the circle and equal to $\frac{mv^2}{r}$.

The following information relates to Questions 10 to 12.

A joy ride consists of passengers in a cart that runs on the inside of a vertical circle of radius 3.2 m, as shown in Figure 4. Kevin, who has a mass of 80 kg, rides in the carriage and is strapped firmly in his seat. The carriage runs at a constant speed at all times.

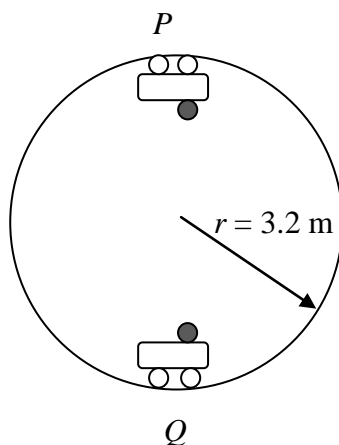

Figure 4

Question 10

Calculate the minimum speed the carriage must have at the top of the circle, location P , to ensure that it continues to move in a uniform circular motion.

Worked solution

At point P , the vector sum of all forces must equal $\frac{mv^2}{r}$. Therefore:

$$mg + F_N = \frac{mv^2}{r}, \text{ where } F_N \text{ is the normal reaction force.}$$

For critical velocity, $F_N = 0$, therefore $mg = \frac{mv^2}{r}$, and $v = \sqrt{rg} = 5.7 \text{ m s}^{-1}$.

5.7 m s^{-1}

2 marks

Mark allocation

- 1 mark for correct expression for speed.
- 1 mark for correct answer.

Question 11

What is the apparent weight of Kevin at the bottom of the ride, at location Q ?

Worked solution

At point Q , the vector sum of all forces must equal $\frac{mv^2}{r}$. Therefore:

$$F_N - mg = \frac{mv^2}{r}, \text{ where } F_N \text{ is the normal reaction force.}$$

$$\text{Therefore, } F_N = mg + \frac{mv^2}{r} = (80 \times 10) + (80 \times \frac{32}{3.2}) = 1600 \text{ N}$$

1600 N

2 marks

Mark allocation

- 1 mark for correct expression of normal force.
- 1 mark for correct answer.
- 2 marks consequential for using the wrong speed from previous question, provided all other working is correct.

Tips

- *Find the vector sum of all forces on the object and remember that this must equal $\frac{mv^2}{r}$. Use proper sign conventions when performing vector addition or subtraction.*

Question 12

At point P , Kevin says he felt ‘weightless’. Explain, making reference to the reason why he felt so.

Worked solution

Apparent weightlessness is felt when the normal reaction force is zero. At point P at critical speed, the normal reaction force is zero; hence, Kevin feels weightless.

1 mark

Mark allocation

- The answer must state that the normal reaction force is zero for apparent weightlessness.

SECTION A – Area of study 1 – continued
TURN OVER

The following information relates to Questions 13 and 14.

A communications satellite called AUSSAT-I of mass 1200 kg is orbiting Earth at an altitude of 650 km.

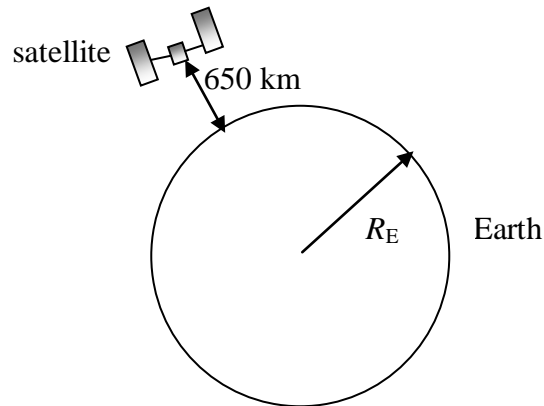

Figure 5

Question 13

Calculate the satellite's speed.

Worked solution

$$\frac{GMm}{r^2} = \frac{mv^2}{r}, \quad \therefore v = \sqrt{\frac{GM}{r}} = \sqrt{\frac{6.67 \times 10^{-11} \times 6 \times 10^{24}}{(6.4 \times 10^6) + (0.65 \times 10^6)}} = 7534 \text{ m s}^{-1}$$

7534 m s^{-1}

3 marks

Mark allocation

- 1 mark for correct expression for speed.
- 1 mark for substituting correct values.
- 1 mark for correct answer.

Question 14

At what height above the Earth's surface would the satellite's weight be 90% of its weight on the surface of Earth? Use gravitational field strength on the surface of Earth as 9.8 m s^{-2} .

Worked solution

Compare the weight on the Earth's surface with weight at a distance R_2 from the centre of Earth.

$$mg_{\text{Earth}} = \frac{GMm}{R_{\text{Earth}}^2}$$

$$mg_{R_2} = \frac{GMm}{R_2^2}$$

$$\text{Therefore, } R_2 = R_{\text{Earth}} \sqrt{\frac{g_{\text{Earth}}}{g_{R_2}}} = 6.4 \times 10^6 \times \sqrt{\frac{9.8}{8.82}} = 6.75 \times 10^6 \text{ m}$$

Distance above Earth = $(6.75 \times 10^6) - (6.4 \times 10^6) \text{ m} = 346\,192 \text{ m}$ or 346.1 km .

$3.46 \times 10^5 \text{ m}$

3 marks

Mark allocation

- 1 mark for correct expression for radius.
- 1 mark for correct substitution of values.
- 1 mark for correct answer.
- Maximum of 2 marks if $g = 10 \text{ m s}^{-2}$ used. Answer would then be 414.7 km.

Tips

- *Note carefully whether distances given are from centre of Earth or from surface. Newton's law of universal gravitation uses distance from centre of Earth.*
- *Practise using a scientific calculator to solve similar problems with large indices.*
- *Although $g = 10 \text{ m s}^{-2}$ is the most commonly used value for gravitational strength, the question should be read carefully to ensure whether an alternative value is suggested.*

SECTION A – Area of study 1 – continued
TURN OVER

The following information relates to Questions 15 and 16.

A projectile of mass 2.0 kg is shot with an initial speed of 10.0 m s^{-1} at an angle of 30° to the horizontal, as shown in Figure 6.

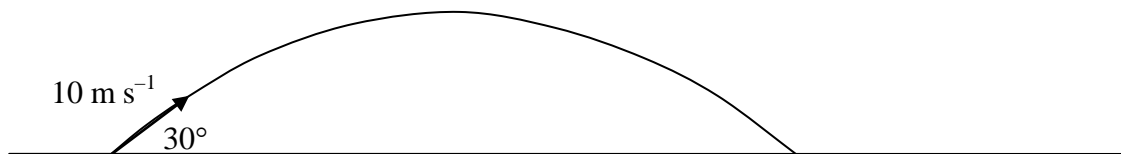

Figure 6

Question 15

Calculate the speed of the projectile 0.6 s after launch.

Worked solution

Let us analyse vertical motion first, taking vectors pointing downwards as negative.

$$x_{\text{vert}} = u_{\text{vert}} t + \frac{1}{2} g t^2 = (5 \times 0.6) - \frac{1}{2} \times 10 \times 0.6^2 = 1.2 \text{ m}$$

The vertical component of velocity at 0.6 s is:

$$v_{\text{vert} = 0.6} = u_{\text{vert}} + g t = 10 \sin 30^\circ - (10 \times 0.6) = -1 \text{ m s}^{-1}$$

Since the horizontal component of speed is constant and is $10 \cos 30^\circ$,

the speed at 0.6 s = $\sqrt{(10 \cos 30^\circ)^2 + 1^2} = 8.72 \text{ m s}^{-1}$

8.72 m s^{-1}

4 marks

Mark allocation

- 1 mark for determining vertical displacement correctly.
- 1 mark for determining vertical component of velocity correctly.
- 1 mark for correct expression for speed at 0.6 s.
- 1 mark for correct answer.

Question 16

Calculate the kinetic energy of the projectile 0.6 s after launch. Show your working.

Worked solution

$$\text{Kinetic energy} = \frac{1}{2} m v^2 = \frac{1}{2} \times 2 \times 8.72^2 = 76.03 \text{ J or } 76 \text{ J.}$$

Alternatively, conservation of energy could be used.

$$\text{Kinetic energy} = \text{total energy} - mgh = \frac{1}{2} \times 2 \times 10^2 - 2 \times 10 \times 1.2 = 76 \text{ J}$$

76 J

2 marks

Mark allocation

- 1 mark for correctly using the expression for kinetic energy and substituting the correct values.
- 1 mark for correct answer.
- 2 marks consequential if (wrong) answer for speed is used from previous question.

Tips

- Use appropriate signs for vector quantities in equations of motion.
- Analyse vertical and horizontal components separately when analysing projectile motion.

The following information relates to Questions 17 and 18.

Ayden is riding a trolley and they are moving at a constant speed of 15.0 m s^{-1} at a certain time t_0 . At one point Ayden decides to jump off the trolley and does so in the same direction as the trolley at a speed of 5.0 m s^{-1} , as shown in Figure 7. Ayden's mass is 45 kg and the trolley's mass is 30 kg .

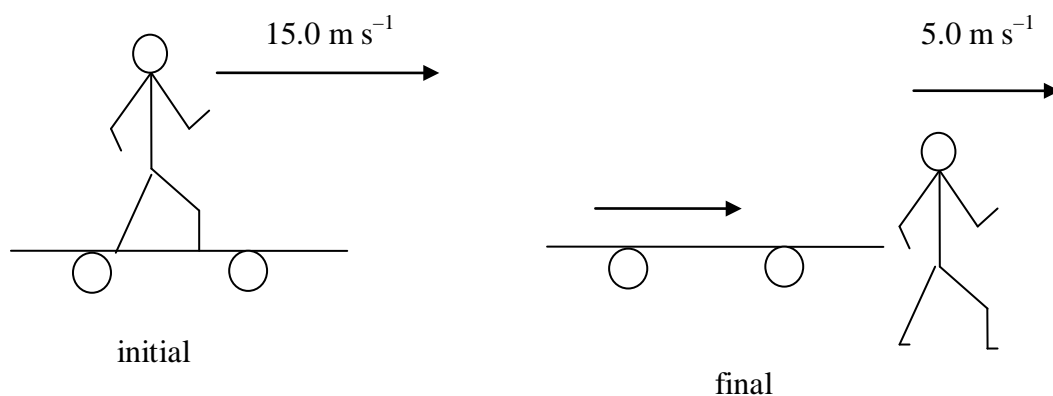

Figure 7

Question 17

What is the speed of the trolley just after Ayden jumps off?

Worked solution

Using conservation of momentum, $\Sigma p_{\text{initial}} = \Sigma p_{\text{final}}$.

$$75 \times 15 = (45 \times 5) + (30 \times v_{\text{trolley}})$$

Therefore, $v_{\text{trolley}} = 30 \text{ m s}^{-1}$.

30 m s^{-1}

2 marks

Mark allocation

- 1 mark for correct use of conservation of momentum formula.
- 1 mark for correct answer.

SECTION A – Area of study 1 – continued
TURN OVER

Question 18

Travelling in a straight line, the trolley comes to a stop at a distance 25.0 m away owing to the force of friction, F_f , between the trolley and the floor. Assuming that F_f is a constant force, find its magnitude. Show your working.

Worked solution

$$v^2 = u^2 + 2ax, \quad \therefore a = \frac{v^2 - u^2}{2x} = \frac{-30^2}{2 \times 25} = 18 \text{ m s}^{-2}$$

$$F_f = ma = 30 \times 18 = 540 \text{ N}$$

540 N

3 marks

Mark allocation

- 1 mark for correct expression for acceleration.
- 1 mark for correct magnitude of acceleration.
- 1 mark for correct magnitude of friction force.

Tip

- *Since momentum is a vector quantity, care must be taken in using the proper signs.*

SECTION A – Core

Area of study 2 – Electronics and photonics

The following information relates to Questions 1 to 3.

Jamie assembles a circuit with a 1.5 V battery, two silicon diodes called P and Q, and two 1000 Ω resistors, as shown in Figure 1. The voltage-current characteristic graph of the silicon diode is shown in Figure 2.

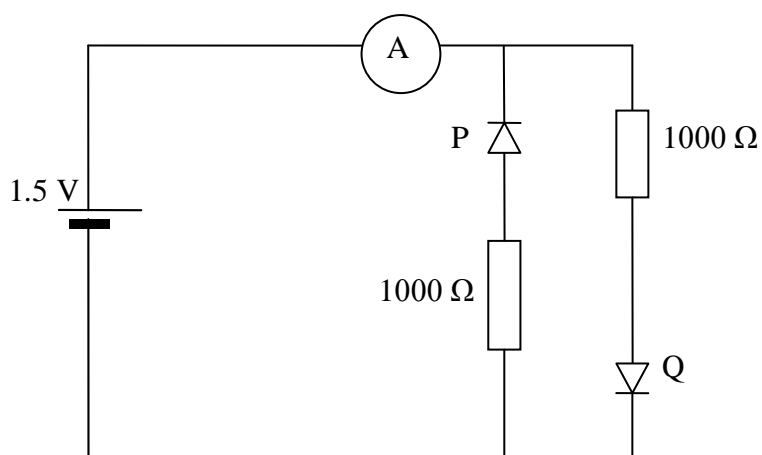

Figure 1

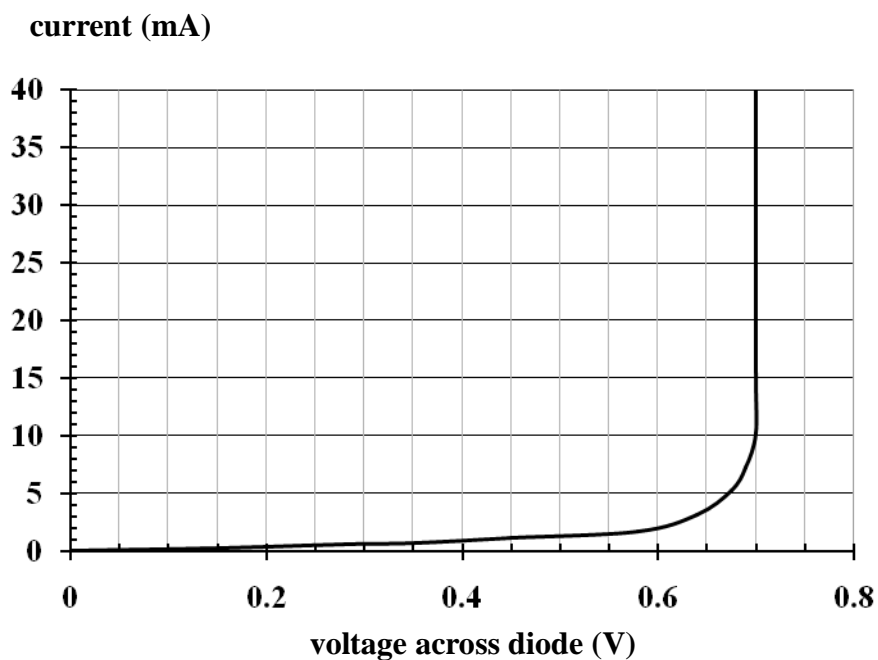

Figure 2

SECTION A – Area of study 2– continued
TURN OVER

Question 1

Calculate the current in the ammeter for the circuit assembled by Jamie.

Worked solution

There will be no current through diode P because it is reverse biased.

Current through the 1000 Ω resistor is:

$$I = \frac{V}{R} = \frac{(1.5 - 0.7)}{1000} = 0.8 \text{ mA}$$

0.8 mA

2 marks

Mark allocation

- 1 mark for recognising that there is no current through a reverse bias diode.
- 1 mark for correct answer.

Question 2

Stacey comes along and removes diode P and replaces it with a 2000 Ω resistor, as shown in Figure 3. What is the reading in the ammeter now?

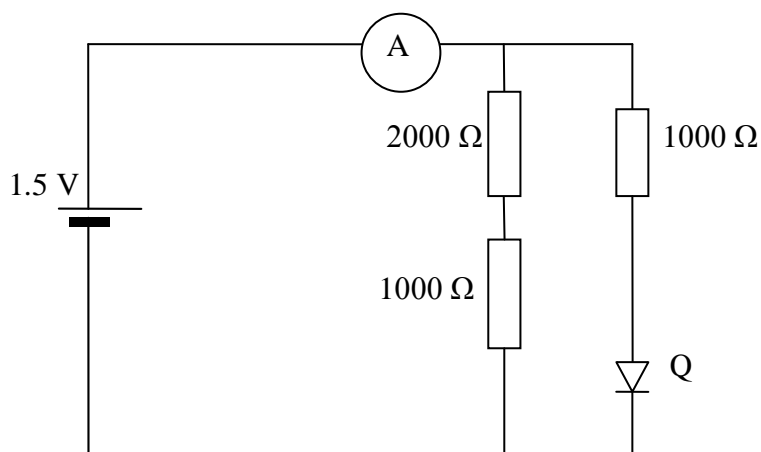

Figure 3

Worked solution

Current through the 2000 Ω resistor is:

$$I = \frac{V}{R} = \frac{1.5}{3000} = 0.5 \text{ mA}$$

Current through diode Q = 0.8 mA

Therefore, current in the ammeter is now $(0.8 + 0.5) \text{ mA} = 1.3 \text{ mA}$

1.3 mA

3 marks

Mark allocation

- 1 mark for estimating current in the 2000 Ω resistor.
- 1 mark for correctly estimating that current through the diode is 0.8 mA.
- 1 mark for correct answer.
- Consequential 1 mark if currents are added but magnitude is wrong from Question 1.

Question 3

Referring to the circuit set up by Stacey, calculate the energy lost in the 2000 Ω resistor in 60 s.

Worked solution

$$E = P \times t = I^2 R t = (0.5 \times 10^{-3})^2 \times 2000 \times 60 = 0.03 \text{ J}$$

0.03 J

2 marks

Mark allocation

- 1 mark for correct use of formula and substituting values correctly.
- 1 mark for correct answer.
- No marks given if not multiplied by time (i.e. 60 s).

Tips

- *Examine the orientation of diodes with care. No current will flow through a diode that is reverse biased.*
- *When estimating energy lost, remember it is equal to power \times time. Check units for time and power.*

The following information relates to Questions 4 and 5.

A streetlight uses a light-emitting diode (LED) to switch the light on or off. A simplified version of the circuit is shown in Figure 4a. The road engineers researching the LED compiled the graph shown in Figure 4b, which shows the variation of resistance with time of day.

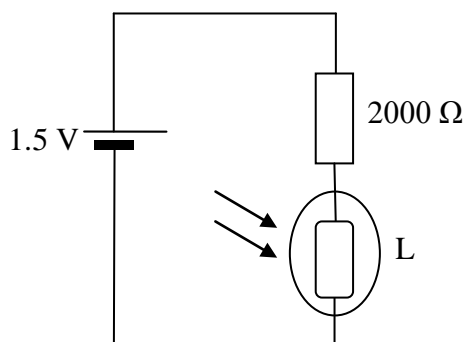

Figure 4a

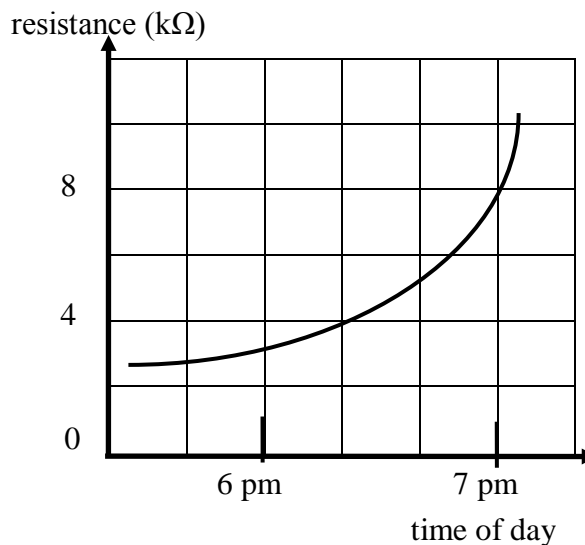

Figure 4b

Question 4

Calculate the ratio of the current in the circuit at 6.00 pm to that at 7.00 pm.

Worked solution

At 6.00 pm, resistance of LED is 3000 Ω.

$$\text{Therefore, } I = \frac{V}{R} = \frac{1.5}{5000} = 0.3 \text{ mA} .$$

At 7.00 pm, resistance of LED is 8000 Ω.

$$\text{Therefore, } I = \frac{V}{R} = \frac{1.5}{10\,000} = 0.15 \text{ mA} .$$

Ratio of current at 6.00 pm to 7.00 pm is $0.3 : 0.15 = 2 : 1$.

2 : 1

3 marks

Mark allocation

- 1 mark for correct estimation of current at 6 pm.
- 1 mark for correct estimation of current at 7 pm.
- 1 mark for calculating correct ratio.

Question 5

During bright daylight, would you expect the voltage across the resistor to increase or decrease? Explain your reasoning.

Worked solution

As the intensity of light increases, the resistance of the LED decreases. This would increase the current in the circuit. Hence, voltage across the resistor would increase.

Increase

2 marks

Mark allocation

- 1 mark for concluding current will increase when resistance decreases.
- 1 mark for final conclusion.
- Full marks should be given if numerical values are used instead of worded explanation.

Tips

- *Remember to develop a logical flow of response to questions requiring predicted outcomes, such as Question 5.*
- *Take care to check that the axes labels and units are in appropriate units.*

The following information relates to Questions 6 to 8.

The performance of two amplifiers is being studied by means of an oscilloscope, which measures input and output signals. The characteristic graphs of the two different amplifiers are shown in Figure 5.

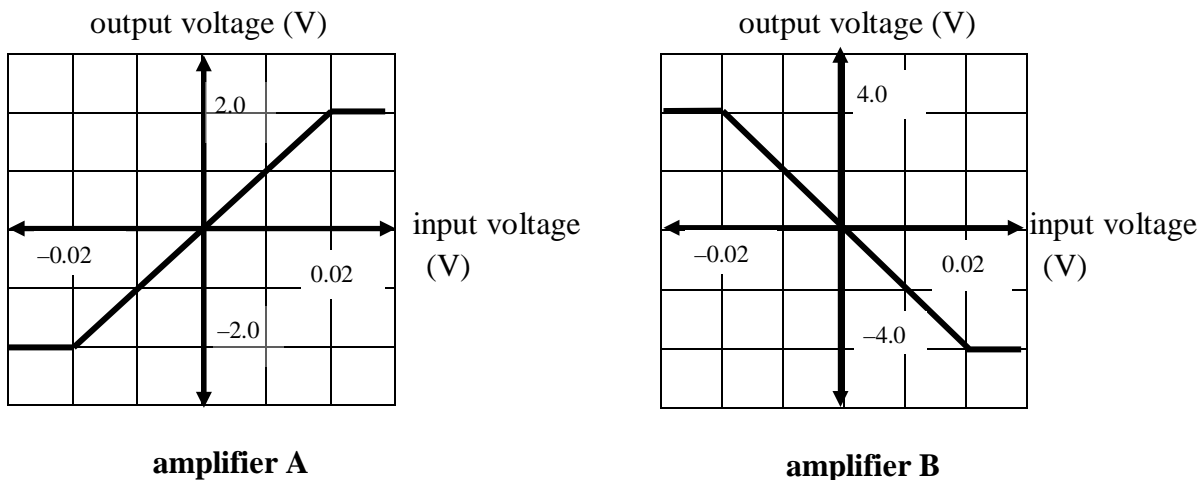

Figure 5

Figure 6 shows the test input signal fed through the amplifiers one at a time.

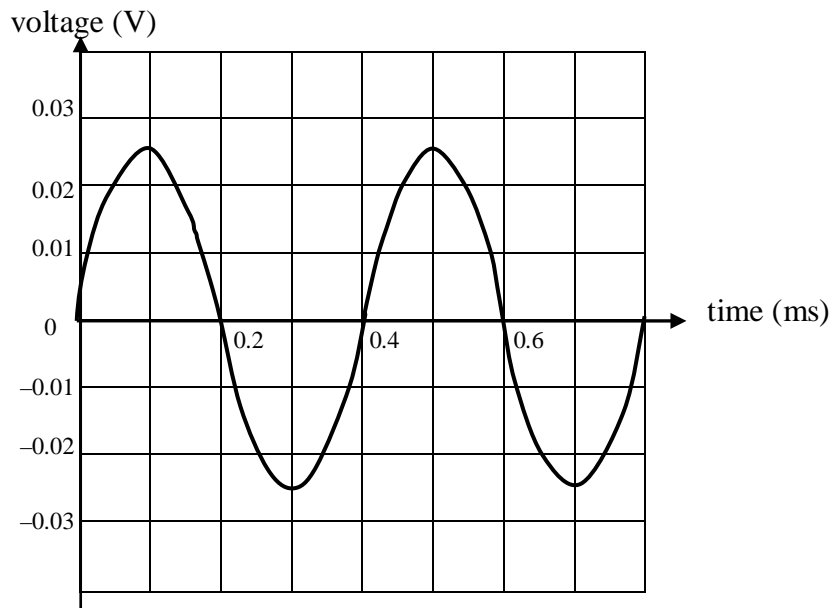
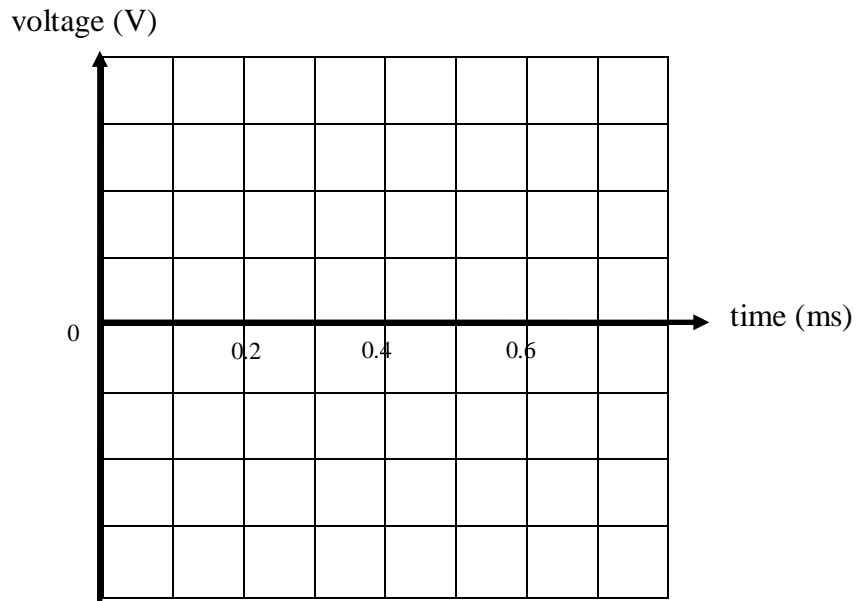

Figure 6

Question 6

On the axes below draw the output graph when the given input signal is fed through amplifier A. Select an appropriate scale on the y-axis.

**Worked solution**

Voltage gain = 100

Amplified peak voltage = $100 \times 0.025 = 2.5 \text{ V}$

Clipping will occur at $\pm 2.0 \text{ V}$.

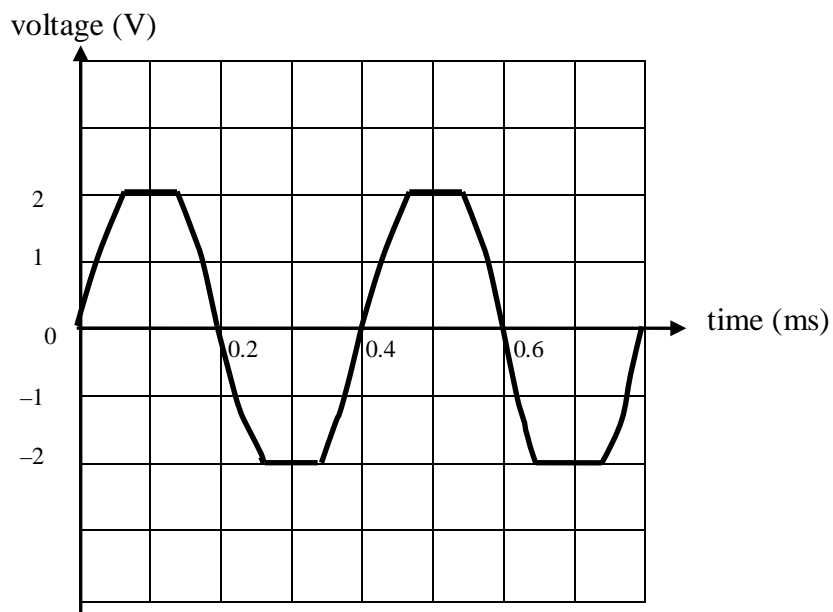

2 marks

Mark allocation

- 1 mark for correct answers for clipping and same frequency.
- 1 mark for correctly showing that it is a non-inverting amplifier.

SECTION A – Area of study 2– continued
TURN OVER

Question 7

On the axes below draw the output graph when the given input graph is fed through amplifier B. Select an appropriate scale on the y-axis.

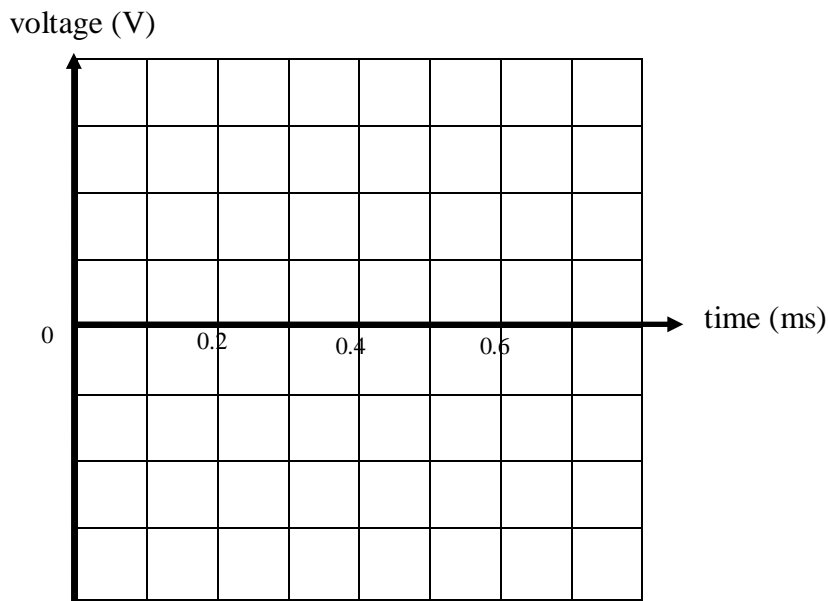
**Worked solution**

Voltage gain = -200 . It is an inverting amplifier.

Amplified peak voltage = $-200 \times 0.025 = \pm 4$

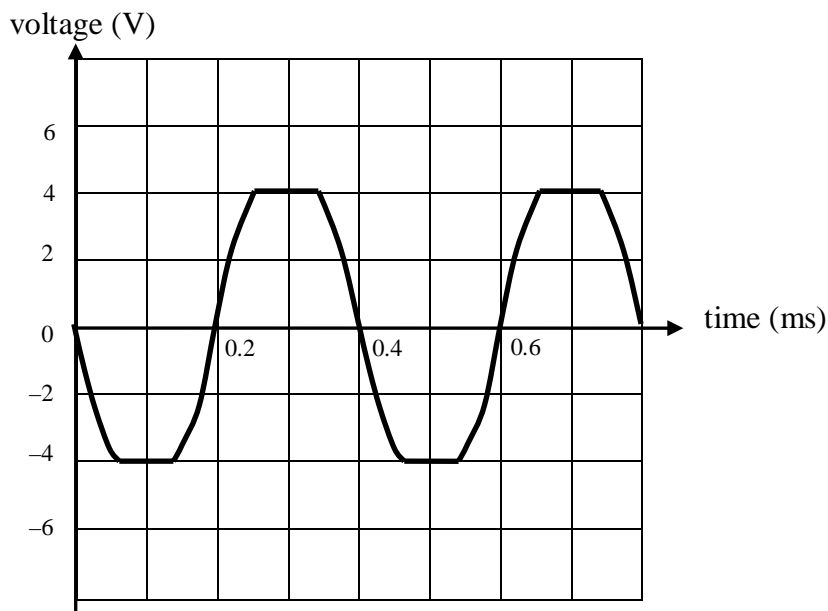

2 marks

Mark allocation

- 1 mark for correctly showing that it is an inverting amplifier.
- 1 mark for correctly calculating clipping occurs at ± 4 .

Question 8

Calculate the ratio of the voltage gain of amplifier A to that of amplifier B.

Worked solution

Voltage gain, A_G , is the gradient of voltage output versus voltage input graphs for an amplifier. Hence:

$$A_{G_A} : A_{G_B} = 100 : (-200) = -1 : 2$$

-1 : 2

2 marks

Mark allocation

- 1 mark for finding the correct magnitude.
- 1 mark for correct use of negative sign.

Tips

- *Examine gradients for the two amplifiers and determine whether they are inverting or not.*
- *Check the possible range of voltage to determine where clipping occurs.*
- *Check that frequency has not changed after amplification.*

The following information relates to Question 9.

The signal shown in Figure 7a is to be transmitted as a modulated signal using the carrier wave shown in Figure 7b.

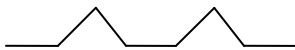

Figure 7a

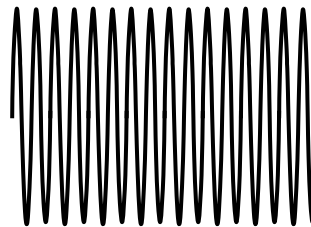
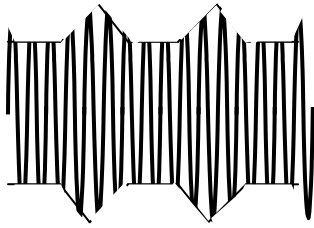
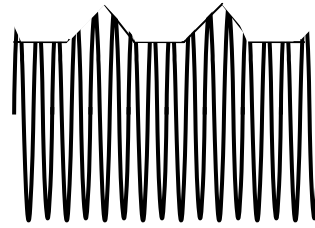
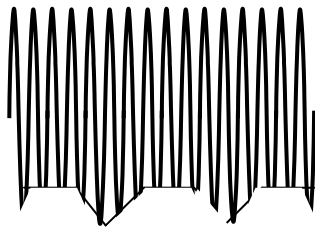
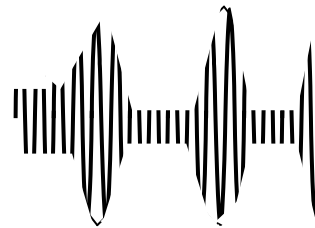

Figure 7b

SECTION A – Area of study 2– continued
TURN OVER

Question 9

Which one of the following four figures best represents the modulated carrier?

**A.****B.****C.****D.****Worked solution**

The y-axis of the carrier wave gets modulated to the frequency and shape of the signal.

A

2 marks

Mark allocation

- 2 marks for correct answer. No part marks.

Tips

- *In this Unit, modulation of the carrier wave is a variation in intensity (i.e. amplitude modulation).*
- *The intensity of the carrier wave is much higher than the signal but the figures are often exaggerated.*

The following information relates to Questions 10 and 11.

A photodiode exhibits the following photocurrent behaviour when illuminated with different light intensity, Φ . It is being used as a switch where the variations in light intensity cause a proportional response to voltage measured across a resistor.

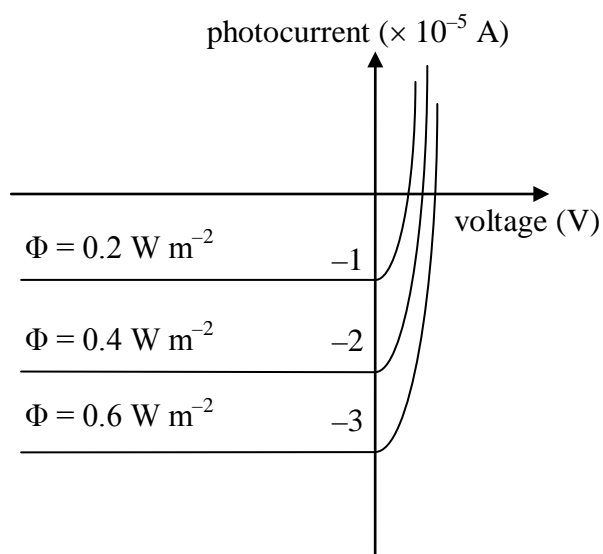
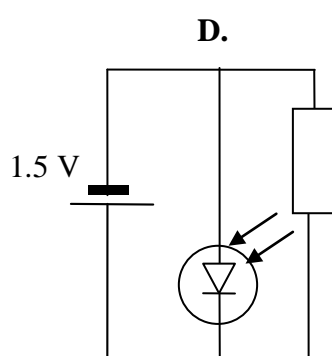
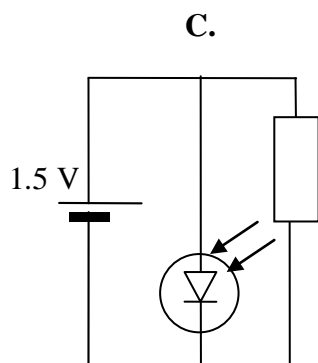
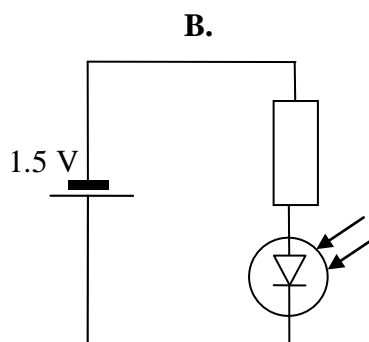
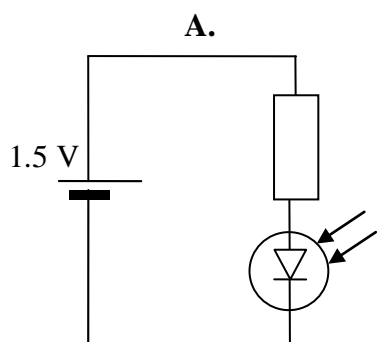

Figure 8

Question 10

Which one of the following is the best circuit for using the photodiode as a switch?



SECTION A – Area of study 2– continued
TURN OVER

Worked solution

Photodiode must be in reverse bias to act as a switch.

B

2 marks

Mark allocation

- 2 marks for correct answer. No part marks.

Question 11

The photodiode described in Figure 8 is used as a switch in reverse bias in order to detect an intruder. What is the voltage across a $1000\ \Omega$ resistor to which the photodiode is connected in reverse bias and light of intensity $0.4\ \text{W m}^{-2}$ illuminates the photodiode?

Worked solution

Photocurrent at $0.4\ \text{W m}^{-2}$ is $2 \times 10^{-5}\ \text{A}$.

$$V = IR = 2 \times 10^{-5} \times 1000 = 0.02\ \text{V}$$

0.02 V

2 marks

Mark allocation

- 1 mark for determining photocurrent correctly.
- 1 mark for calculating voltage correctly.

Tips

- *Photocurrent is often given in μA . Take care when converting to amperes.*
- *A photodiode works as a switch in reverse bias.*

END OF SECTION A

SECTION B – Detailed studies

Detailed study 1 – Einstein’s special relativity

The following information relates to Questions 1 and 2.

In the year 2300 AD, a spaceship is sent at a speed of $0.9 c$ to a star 30 light-years away.

Question 1

Which one of the following gives the time taken for the spaceship to reach the star, as determined by an observer on Earth?

- A. 27.0 years
- B. 33.3 years**
- C. 60.0 years
- D. 14.5 years

B

Worked solution

An observer on Earth measures dilated time, so:

$$t = \frac{L_0}{v} = \frac{30 \text{ light-years}}{0.9 c} = 33.3 \text{ years}$$

Question 2

Which one of the following gives the time taken for the spaceship to reach the star, as determined by an observer on the spaceship?

- A. 33.3 years
- B. 27.0 years
- C. 14.5 years**
- D. 60.0 years

C

Worked solution

An observer on the spaceship will measure proper time, so:

$$t_0 = t \sqrt{1 - \frac{v^2}{c^2}} = 33.3 \sqrt{1 - 0.9^2} = 14.5 \text{ years}$$

Tips

- *First determine which is the observer’s frame of reference, and hence which quantity is proper time.*

Question 3

An asteroid flies past Earth's outer atmosphere at $0.7c$. Astronauts on the space station measure its length to be 110 m. Which one of the following is the closest in magnitude to the length the astronauts would have measured the asteroid to be if they had actually landed on the asteroid?

- A. 134 m
- B. 145 m
- C. **154 m**
- D. 165 m

C

Worked solution

Using $L = L_0 \sqrt{1 - \frac{v^2}{c^2}}$

$$L_0 = \frac{L}{\sqrt{1 - \frac{v^2}{c^2}}} = \frac{110}{\sqrt{1 - 0.7^2}} = 154 \text{ m}$$

Tips

- *First determine which is the observer's frame of reference, and hence which quantity is proper time.*

Question 4

Which one of the following statements is **not** part of Einstein's special theory of relativity?

- A. The speed of light in vacuum does not depend on the speed of the observer or the source.
- B. The laws of physics are the same for an observer, whichever reference frame the observer may be in.
- C. The speed of light in vacuum is the same in all inertial reference frames.
- D. **The laws of physics are the same only in a stationary reference frame.**

D

Worked solution

Options A, B and C are core statements of Einstein's special theory of relativity.

Tip

- *Summarise statements of Einstein's special theory of relativity.*

Question 5

For an object travelling close to the speed of light, which one of the following statements is most likely to be true?

- A. Proper time is $>$ relativistic time, and proper length $<$ relativistic length.
- B. Proper time is $<$ relativistic time, and proper length $>$ relativistic length.**
- C. Proper time is $>$ relativistic time, and proper length $>$ relativistic length.
- D. Proper time is $<$ relativistic time, and proper length $<$ relativistic length.

B

Worked solution

When objects are travelling close to the speed of light, $t > t_0$ and $L < L_0$.

Tip

- Remember the phrases ‘time dilation’ and ‘length contraction’, which apply to objects travelling close to the speed of light.

Question 6

Which one of the following gives the rest energy of an electron?

Mass of electron is 9.1×10^{-31} kg.

- A. 8.2×10^{-14} J**
- B. 4.1×10^{-14} J
- C. 2.5×10^{-13} J
- D. 2.7×10^{-14} J

A

Worked solution

The rest energy of the electron is $E = mc^2 = 9.1 \times 10^{-31} \times (3 \times 10^8)^2 = 8.19 \times 10^{-14}$ J.

Tip

Remember: At ‘rest’ means $v = 0$.

Question 7

Which one of the following is the closest in value to the mass of an electron moving with a speed of $0.68 c$?

- A. 1.6×10^{-31} kg
- B. 9.1×10^{-31} kg
- C. 1.2×10^{-30} kg
- D. 6.7×10^{-31} kg**

D

Worked solution

Relativistic mass would be $m = \frac{m_0}{\sqrt{1 - \frac{v^2}{c^2}}} = \frac{9.1 \times 10^{-31}}{\sqrt{1 - 0.68^2}} = 1.24 \times 10^{-30} \text{ kg.}$

Tip

- *As objects travel close to the speed of light, relativistic mass increases and approaches infinity*

Question 8

Which one of the following gives the kinetic energy of an electron moving at the speed of $0.68 c$?

- A. $9.9 \times 10^{-15} \text{ J}$
- B. $8.2 \times 10^{-14} \text{ J}$
- C. $2.7 \times 10^{-13} \text{ J}$
- D. $1.7 \times 10^{-14} \text{ J}$

A

Worked solution

Kinetic energy, $E_k = c^2(m - m_0)$

$$= (3 \times 10^8)^2 \times (1.24 \times 10^{-30} - 9.1 \times 10^{-31}) = 9.9 \times 10^{-15} \text{ J}$$

Tip

- *When objects travel close to the speed of light, relativistic mass must be used for determining kinetic energy.*

The following information relates to Questions 9 and 10.

In the experiment conducted by Michaelson and Morley, light was shone from a source to a half-silvered mirror, such that part of the light reflected to mirror M_1 and the other part transmitted to M_2 . A simplified diagram of the experimental set-up is shown in Figure 1.

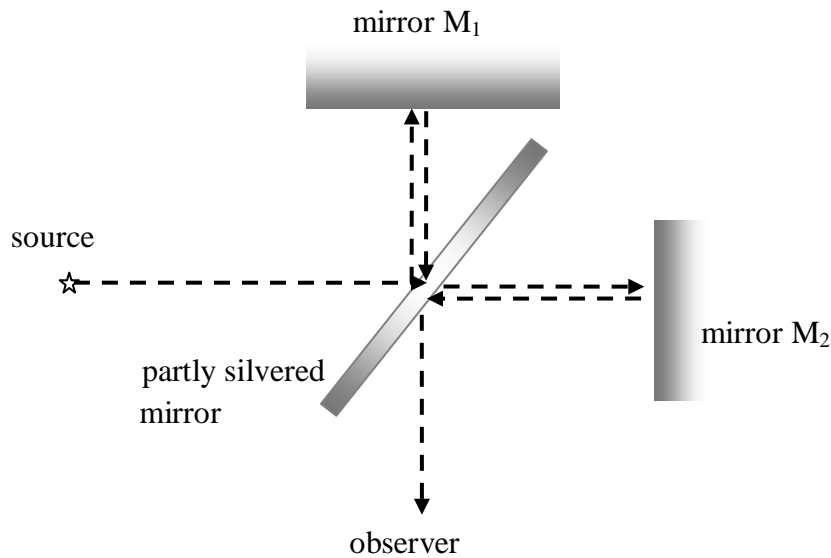

Figure 1

Question 9

Which one of the following properties of light was fundamental to the understanding of the experiment?

- A. reflection
- B. interference**
- C. diffraction
- D. refraction

B

Worked solution

Interference effects from two light beams of known path difference were fundamental to this experiment. Hence, correct answer is B.

SECTION B – Detailed study 1 – continued
TURN OVER

Question 10

Which one of the following statements is **incorrect** about the experiment and what it set out to achieve?

- A. The experiment was designed to measure the speed of ether relative to Earth.
- B. The experiment hoped to discover an absolute reference frame.
- C. The experiment was based on the speed of light being constant in all inertial reference frames.
- D. **For the experiment to be successful it was vital that the half-silvered mirror allowed exactly half the light to get to each mirror.**

D

Worked solution

Interference effects would still occur if one light beam was less intense. Hence, D is the incorrect statement.

Tips

- *Document clear statements about the process and objectives of the Michaelson–Morley experiment.*
- *In many ways the ‘null’ result was not a failure but a success.*

Question 11

Which one of the following statements **best describes** inertial reference frames?

- A. They do not move.
- B. They move with constant acceleration.
- C. **They move with zero acceleration.**
- D. They move with increasing acceleration.

C

Worked solution

Inertial reference frames are non-accelerating frames. Hence, correct answer is C.

Question 12

Two spaceships, Freddie and Khokho, fly in the opposite direction from a space launching pad, each with a speed of $0.65c$, as shown in Figure 2.

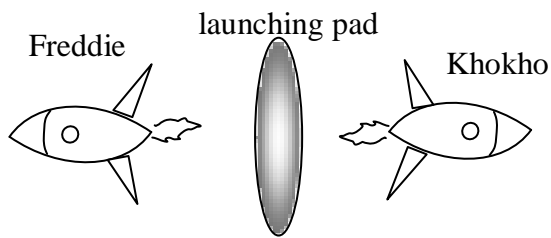

Figure 2

What is the speed of Freddie as measured by an observer on Khokho?

- A. $1.3c$
- B. $0.65c$
- C. **$0.91c$**
- D. $0.79c$

Worked solution

$$v_{FK} = \frac{v_F - v_K}{1 - \frac{v_F v_K}{c^2}} = \frac{0.65c - (-0.65c)}{1 - \frac{0.65c \times (-0.65)c}{c^2}} = 0.91c$$

C

Tip

- Calculations based on Newtonian physics will give a relative velocity of $1.3c$, which is not possible.

Question 13

Which of the following **best represents** the mass of an object as it approaches a speed close to that of light?

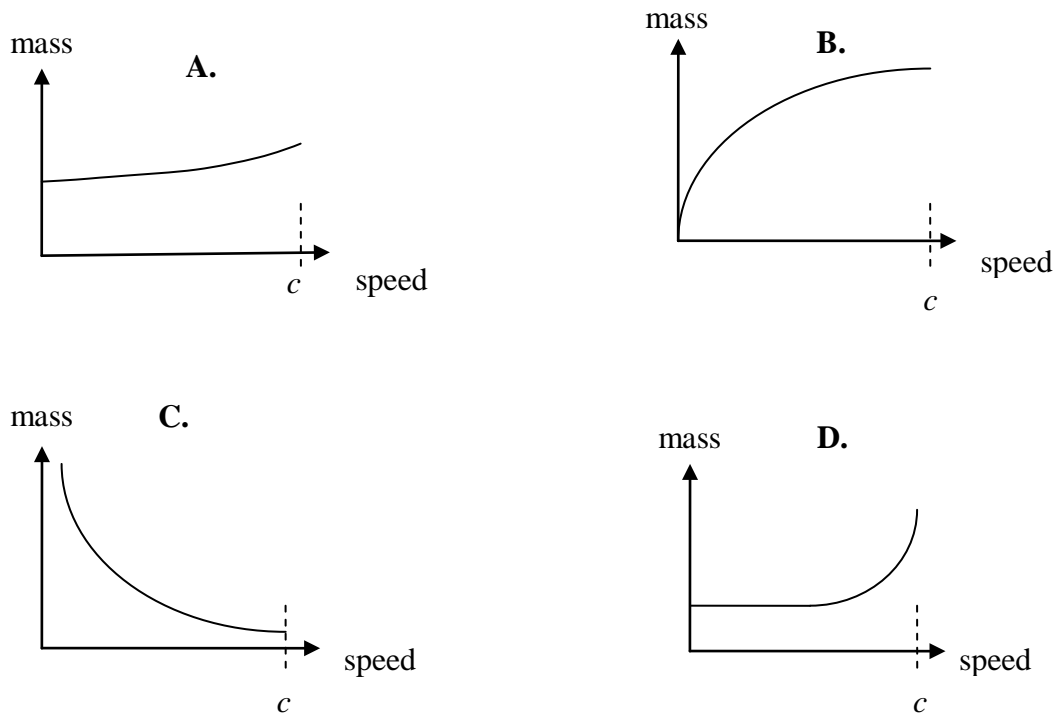

Figure 3

Worked solution

Relativistic mass approaches infinity as speed of the object approaches that of light. Hence, correct answer is D.

D

Tips

- Summarise what changes occur to length, mass and time as objects travel close to the speed of light.
- Remember that objects cannot travel faster than the speed of light.

SECTION B – Detailed studies

Detailed study 2 – Materials and their use in structures

The following information relates to Questions 1 to 5.

The stress–strain graphs until fracture for three different materials being tested under tension in a laboratory are shown in Figure 1. Each sample is 5.0 cm long and has a square cross-section of dimensions 1.0 cm × 1.0 cm) [1 MPa = 10⁶ Nm⁻²].

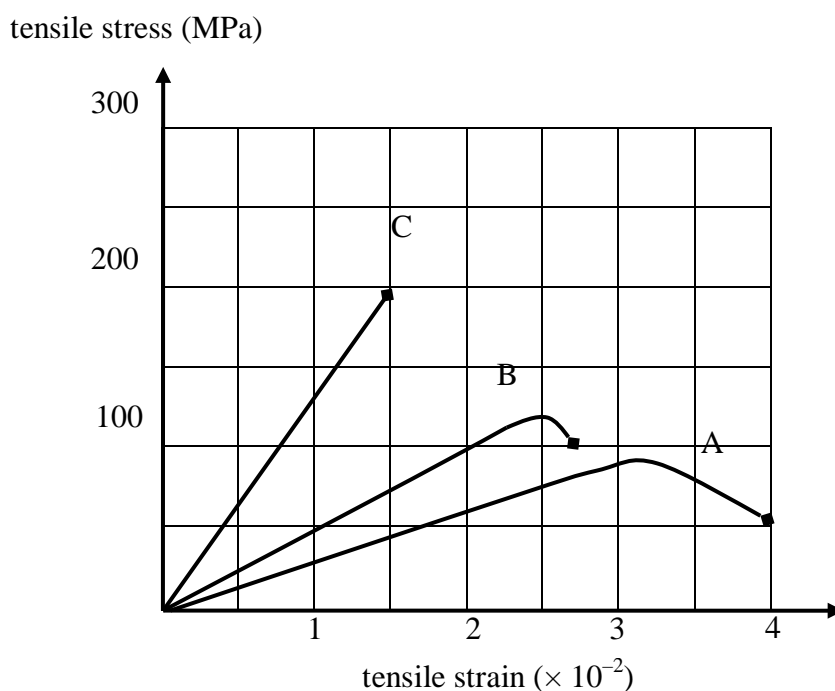

Figure 1

Question 1

Regarding the three materials, which of the following statements is **correct**?

- A. C is brittle and B is tougher than A.
- B. C is brittle and A is tougher than B.**
- C. A is brittle and B is tougher than A.
- D. B is brittle and C is tougher than A.

B

Worked solution

Material C is brittle because it has no plastic region.

Material A is tougher because the area under the stress–strain graph is greatest.

Question 2

Young's modulus of material C is closest in magnitude to

- A. 133.3 MPa
- B. 1.3×10^5 MPa
- C. 1.3×10^4 MPa
- D. 1.5 MPa

C

Worked solution

Young's modulus = gradient of the stress–strain graph = $\frac{200}{0.015} = 1.3 \times 10^4$ MPa

Question 3

The force needed to extend material B from its original length of 5.0 cm to a length of 5.1 cm is closest in value to

- A. 1000 N
- B. **10 000 N**
- C. 100 000 N
- D. 100 N

B

Worked solution

An extension of 0.1 cm is a strain of 0.02, which is in the linear region.

Therefore, since $E = \frac{\sigma}{\varepsilon} = \frac{F \times L}{A \times \Delta L}$, then

$$F = \frac{E A \Delta L}{L} = \frac{75 \times 10^6 \times 0.01 \times 0.01 \times 0.001}{0.015 \times 0.05} = 10000 \text{ N}$$

Question 4

When a tensile stress of 200 MPa is applied to material A, the strain energy per unit volume in the sample is

- A. 7.5 J m^{-3}
- B. $7.5 \times 10^3 \text{ J m}^{-3}$
- C. 1500 J m^{-3}
- D. **$1.5 \times 10^6 \text{ J m}^{-3}$**

D

Worked solution

Strain energy per volume (J m^{-3}) = area under stress–strain graph = $1.5 \times 10^6 \text{ J m}^{-3}$.

Question 5

The spring constant of material B in the elastic region is

- A. $1.0 \times 10^7 \text{ N m}^{-1}$
- B. 5000 MPa
- C. 5000 N m^{-1}
- D. 10^7 Pa

A

Worked solution

Using $E = \frac{kL}{A}$,

$$\therefore k = \frac{EA}{L} = \frac{5 \times 10^9 \times 0.01 \times 0.01}{0.05} = 1 \times 10^7 \text{ N m}^{-1}$$

Tips

- Check carefully the quantities and units on both axes of the graph.
- Carry out your working clearly. Even though there are no marks for working, it is good practice as it assists with answer checking.

The following information relates to Questions 6 and 7.

Tahlia stands 0.40 m away from the end of a 2.40 m wooden plank. The plank is fixed firmly into a wall, as shown in Figure 2. The mass of Tahlia is 70.0 kg and that of the plank is 35.0 kg.

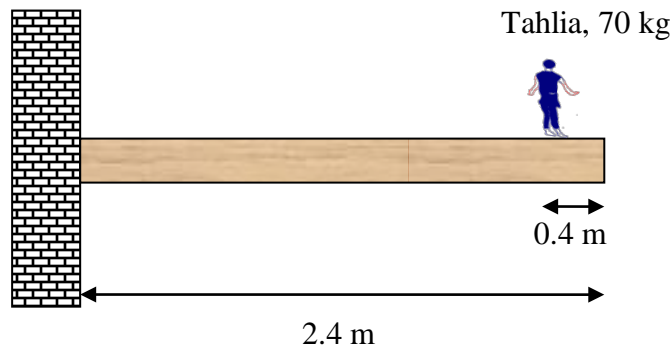

Figure 2

Question 6

Which one of the following is the **best estimate** of the torque exerted by Tahlia on the wall?

- A. 1680 N m
- B. 140 N m
- C. 1400 N m
- D. 280 N m

C

Worked solution

$$\text{Torque} = \text{force} \times \text{distance} = 700 \times 2.0 = 1400 \text{ N m}$$

Question 7

To strengthen the structure further, John ties a cable to the structure 1.0 m from the plank's end at an angle of 30° to the horizontal, as shown in Figure 3, and also places a hinge between the plank and the wall. Which of the following is the magnitude of the tension force in the cable?

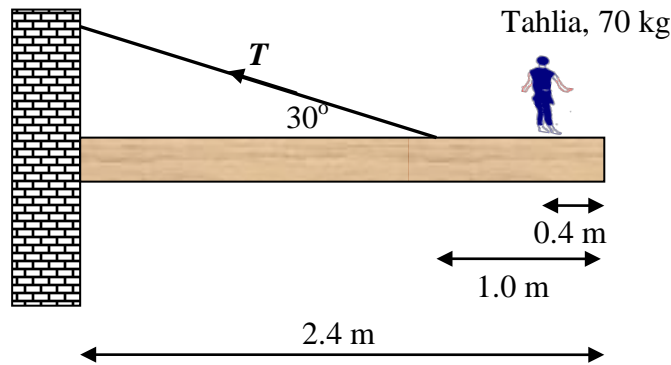

- A. 2600 N
- B. 1501 N
- C. 1050 N
- D. 909 N

A

Worked solution

Consider torque around the point where the plank is inserted into the wall.

$$(T \sin 30^\circ \times 1.4) = (350 \times 1.2) + (700 \times 2)$$

$$T = 2600 \text{ N}$$

Tips

- *Torque is a vector quantity and proper sign convention must be used.*
- *Consider components of forces in their appropriate directions.*

Question 8

Caroline is sitting on a see-saw 1.5 m away from its centre. Jack then sits down at the see-saw's other end such that the plank is balanced perfectly horizontal, as shown in Figure 3. The mass of Caroline is 60.0 kg and Jack is 70.0 kg. How far from the centre of the plank, R , did Jack sit? Select the best answer from the options provided.

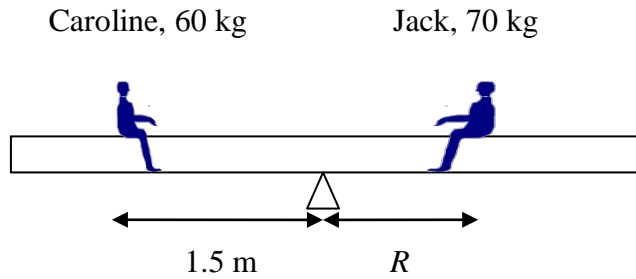

Figure 3

- A. 1.1 m
- B. 1.5 m
- C. 1.4 m
- D. 1.3 m

D

Worked solution

Consider torque around the centre point (also called the *fulcrum*).

$$(600 \times 1.5) = (700 \times R)$$

$$R = 1.3 \text{ m}$$

Tip

- *By considering torque around the fulcrum there is no need to evaluate the unknown reaction force at the fulcrum.*

The following information relates to Questions 9 and 10.

A shop sign of mass 20.0 kg is strung up at the entrance of the shop by two cables to the roof and the side wall, as shown in Figure 4. The shop sign is in equilibrium.

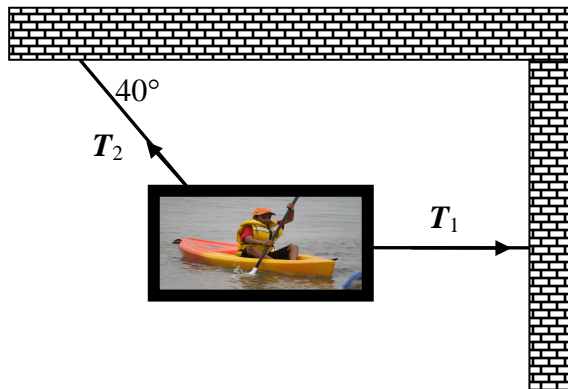

Figure 4

Question 9

Which one of the following is the closest in magnitude of the force T_1 ?

- A. 238 N
- B. 311 N
- C. 200 N
- C. 261 N

A

Worked solution

Solution found using simultaneous equations. See Worked solution for Question 10.

Question 10

Which one of the following is the closest in magnitude of the force T_2 ?

- A. 238 N
- B. 311 N
- C. 200 N
- D. 261 N

B

SECTION B – Detailed study 2 – continued
TURN OVER

Worked solution

$$T_2 \cos 40^\circ = T_1$$

$$T_2 \sin 40^\circ = 200$$

Therefore, $T_2 = 311.15 \text{ N}$; and $T_1 = 238.35 \text{ N}$.

Tips

- For two unknowns, two simultaneous equations are needed.
- Take due care when obtaining correct components.

The following information relates to Questions 11 to 13.

Wires of two materials, sample A and sample B, are being investigated by applying a tensile force on them. Each sample is 6.0 cm long and has a cross-sectional area of $3.0 \times 10^{-8} \text{ m}^2$. The force versus extension behaviour of the two materials is shown in Figure 5.

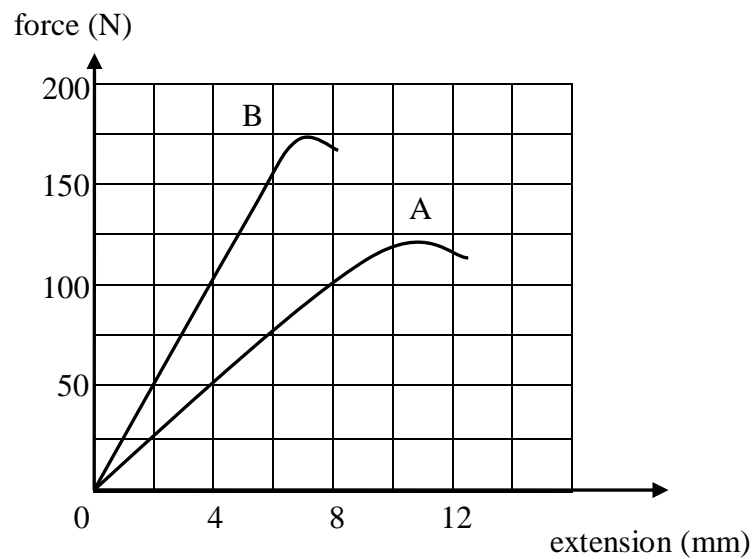

Figure 5

Question 11

Which one of the following is the closest in magnitude to the spring constant of sample A?

- A. 50 N m
 B. 12500 N m⁻¹
 C. 12.5 N m⁻¹
 D. 0.05 N m

B

Worked solution

$$\text{Spring constant, } k = \frac{\text{force}}{\text{extension}} = \frac{25}{0.002} = 12\,500 \text{ N m}^{-1}$$

Question 12

A mass of 5.0 kg is suspended from sample B. The stress applied to the sample is then closest in magnitude to

- A. $150 \times 10^8 \text{ N m}^{-2}$
- B. $150 \times 10^8 \text{ MPa}$
- C. **1670 MPa**
- D. $1670 \times 10^8 \text{ N m}^{-2}$

C

Worked solution

$$\text{Stress} = \frac{\text{force}}{\text{area}} = \frac{50}{3 \times 10^{-8}} = 1670 \text{ MPa}$$

Question 13

Which one of the following is the ratio of Young's modulus of sample A to that of sample B?

- A. **1 : 2**
- B. 2 : 1
- C. 2 : 5
- D. 5 : 2

A

Worked solution

$$\text{Since } E_A = \frac{\sigma}{\varepsilon} = \frac{F \times L}{A \times \Delta L_A} \text{ and } E_B = \frac{\sigma}{\varepsilon} = \frac{F \times L}{A \times \Delta L_B}.$$

Therefore, $\frac{E_A}{E_B} = \frac{\Delta L_B}{\Delta L_A} = \frac{2}{4} = \frac{1}{2}$ for the same force, which in this case we could take as 50 N.

Tips

- Check the units on the axes.
- Remember to develop a mathematical relationship between the spring constant and Young's modulus.

END OF DETAILED STUDY 2
SECTION B – continued
TURN OVER

SECTION B – Detailed studies
Detailed study 3 – Further electronics

The following information relates to Questions 1 to 3.

Gabriela desires to have a rectified power supply for a load resistor device whose resistance is R_L to be initially equal to $500\ \Omega$. She assembles the circuit shown in Figure 1, which consists of a $240\ \text{V}_{\text{RMS}}$, $50\ \text{Hz}$ supply, a transformer and a $200\ \mu\text{F}$ capacitor. The transformer has a ratio of turns primary : secondary of $10 : 1$. Gabriela studies the voltage–time waveform across various points of the circuit using a cathode ray oscilloscope (CRO).

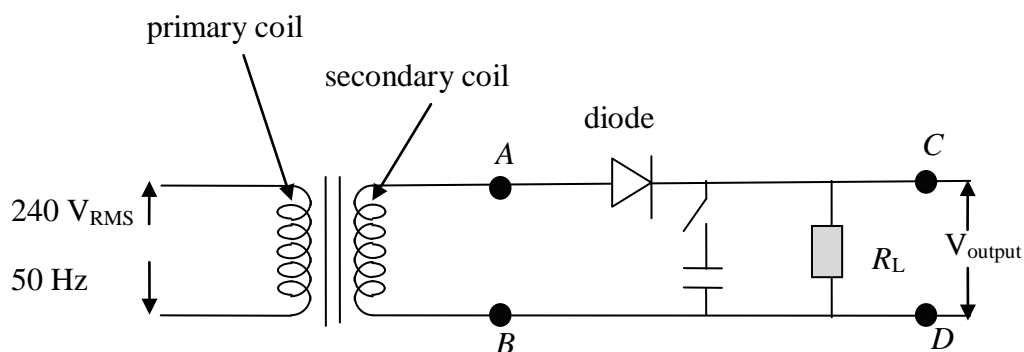

Figure 1

Question 1

When the CRO is connected across the points A and B, the following trace is observed (see Figure 2).

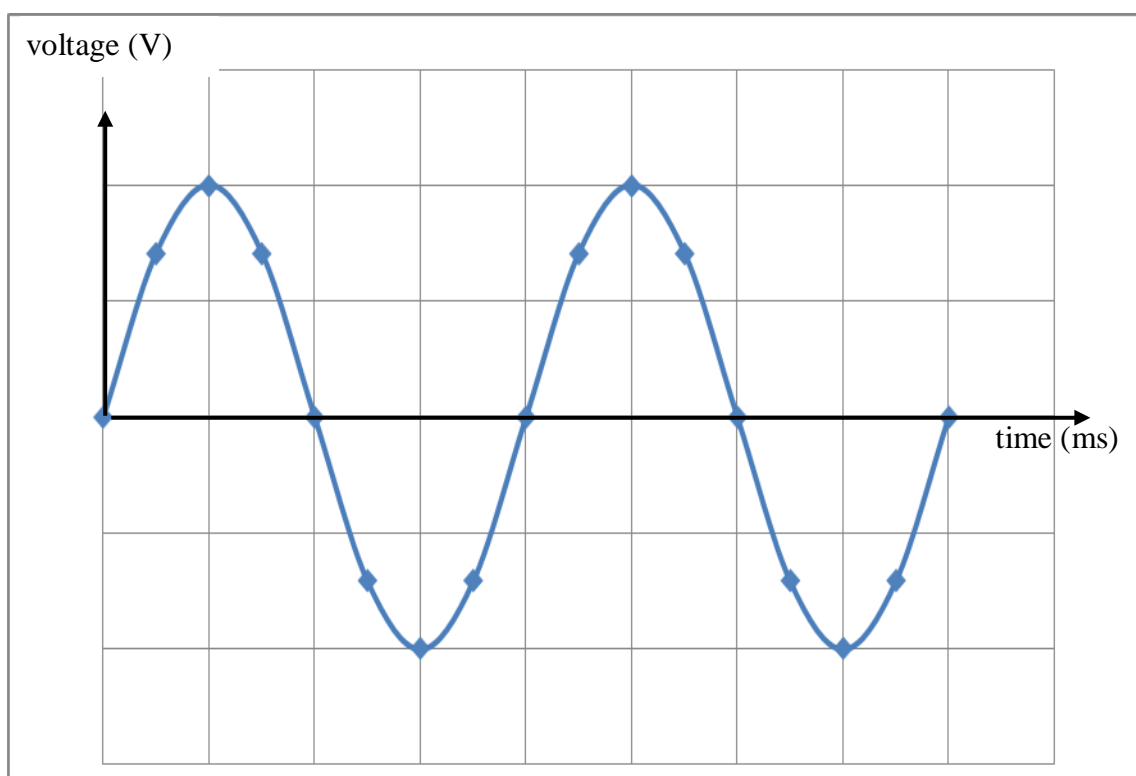

Figure 2

Which of the following statements is the best representation of the x -axis and y -axis *scale* for the CRO trace? Each square in the figure represents sides of 1 cm.

- A. 1 cm = 20 ms, 1 cm = 17 V
- B. 1 cm = 0.01 ms, 1 cm = 120 V
- C. **1 cm = 5 ms, 1 cm = 17 V**
- D. 1 cm = 10 ms, 1 cm = 24 V

C

Worked solution

Between points A and B , the CRO measures the output from the transformer. Hence, the secondary voltage output is $\frac{240}{10} = 24 \text{ V}_{\text{RMS}} = 34 \text{ V}_{\text{peak}}$.

Time period is 0.02 s. Hence, on the x -axis 1 cm = 5 ms.

Hence, correct answer is C.

Question 2

Gabriela now connects the CRO across points C and D . With the switch **disconnected**, the voltage waveform across points C and D is closest *in shape* to which one of the following?

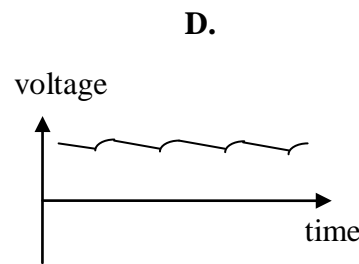
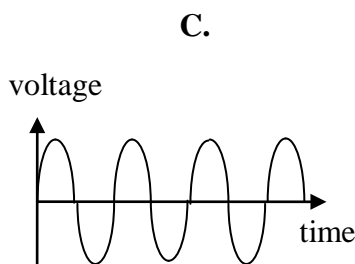
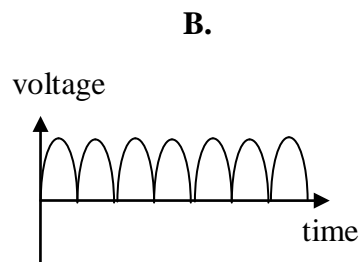
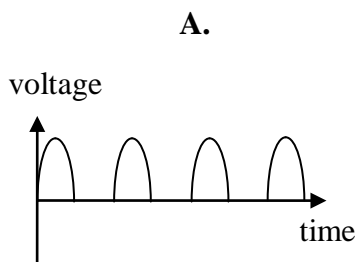

A

Worked solution

With no capacitor in the circuit, half-wave rectification will occur. Hence, correct answer is A.

SECTION B – Detailed study 3 – continued
TURN OVER

Question 3

With the switch now *on* so that the capacitor is part of the circuit, which of the following is the **best representation** of the wave form across points *C* and *D*?

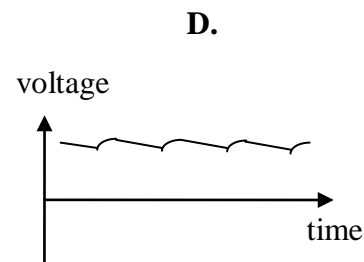
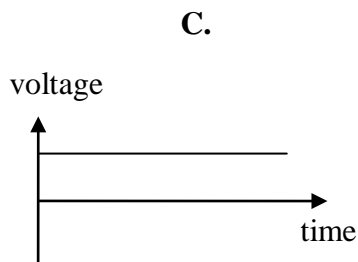
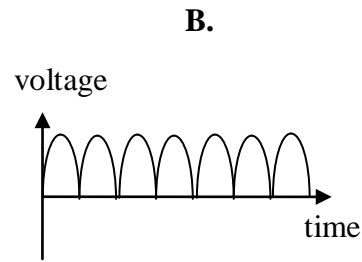
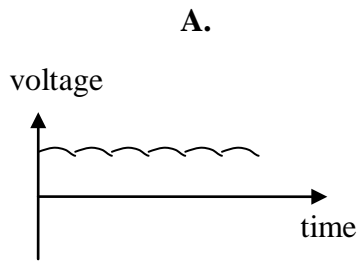

D

Worked solution

Half-wave rectification with some smoothing will occur. Hence, correct answer is D. Option A shows no smoothing and so is not the best answer.

Tips

- *Learn to distinguish between half-wave and full-wave rectification.*
- *Remember that a capacitor is not going to convert an AC wave form to a perfect DC signal with no ripples.*

The following information relates to Questions 4 to 7.

An RC circuit is assembled as shown in Figure 3. It consists of a switch, a 6.0 V battery, a 5000 Ω resistor and a 500 μF capacitor. The variation of voltage with time across the capacitor and resistor is then studied.

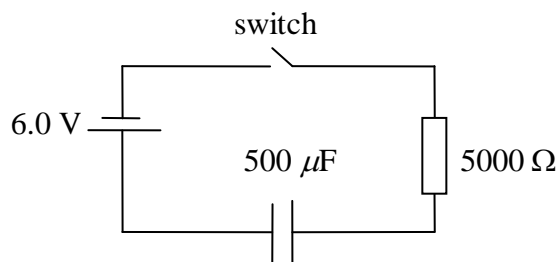

Figure 3

Question 4

Which one of the following is the **best estimate** for the time constant of the RC circuit?

- A. 2500 s
- B. 100 s
- C. 2.5 s
- D. 1.0 s

Worked solution

$$\tau = RC = 5000 \times 500 \times 10^{-6} \text{ s} = 2.5 \text{ s}$$

C

SECTION B – Detailed study 3 – continued
TURN OVER

Question 5

When the switch is **closed** and the **circuit is fully connected**, which of the following graphs best describe the behaviour of *voltage* with *time* across the resistor and the capacitor?

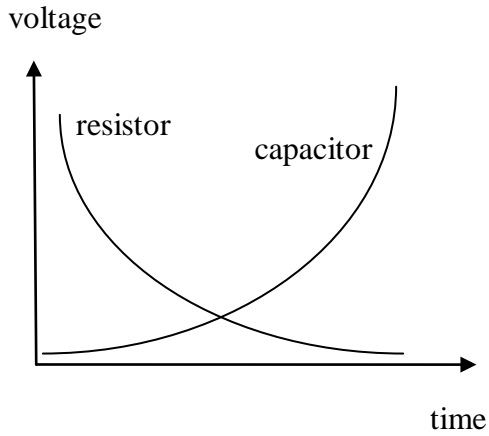
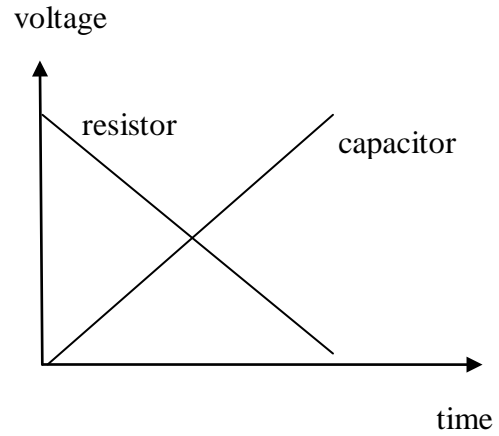
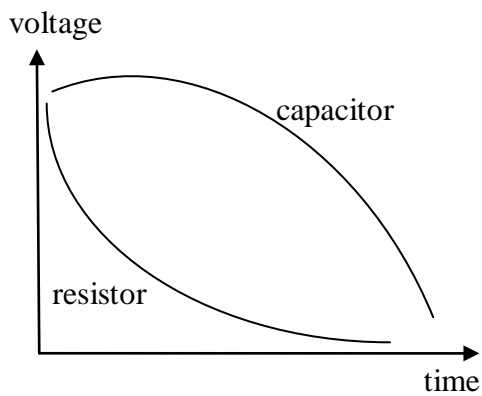
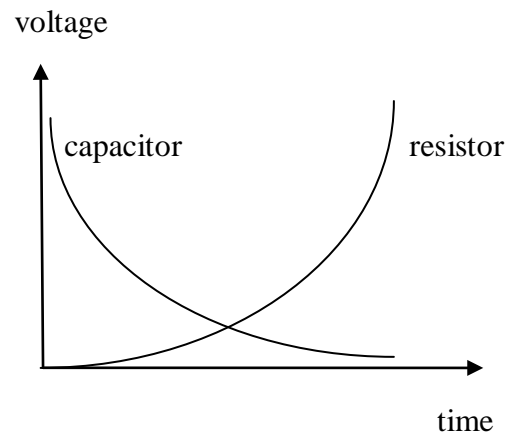
A.**B.****C.****D.**

A

Worked solution

The voltage across the capacitor will build up at the expense of the voltage across the resistor. Full charging of the capacitor will occur at 5τ . Hence, correct answer is A.

Question 6

Once the capacitor has been fully charged, the switch is **disconnected**. Which one of the following is the closest in value to the time from the moment the switch is disconnected for the voltage across the resistor to be 2.2 V?

- A. 0.5 s
- B. 1.2 s
- C. 2.5 s
- D. 3.5 s

C

Worked solution

It takes one time constant for the capacitor to charge up 63%. The remaining 37% will be across the resistor. 2.2 V is 37% of 6 V. Hence, time required is 2.5 s.

Question 7

The resistor and capacitor are now replaced with those of different magnitudes. The new resistor is 10 k Ω and the value of the capacitor is unknown. When the switch and the circuit is connected, it takes 20.0 s to fully charge the capacitor. The capacitance of the unknown capacitor is

- A. 100 μF
- B. 400 μF
- C. 600 μF
- D. 800 μF

B

Worked solution

$$\text{Time constant } \tau = RC = \frac{20}{5} = 4 \text{ s.}$$

$$C = \frac{\tau}{R} = \frac{4}{10000} = 400 \mu\text{F}$$

Tips

- *It takes 5 time-constants to fully charge a capacitor.*
- *The voltage drop across various parts of the circuit must add up to the battery voltage.*

The following information relates to Questions 8 to 11.

To operate a device of resistance R_L , Joseph connects a circuit with a resistor, R_1 , of value $100\ \Omega$, a $25\ \mu\text{F}$ capacitor, a $6.0\ \text{V}$ Zener diode and a $9.0\ \text{V}$ (peak) AC power supply, as shown in Figure 4.

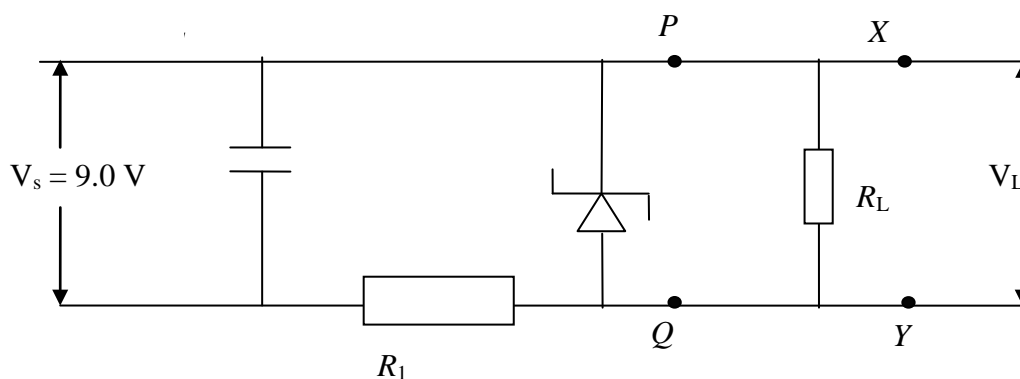

Figure 4

Question 8

Which of the following is closest in value to the current flowing through the resistor R_1 ?

- A. 30 mA
- B. 60 mA
- C. 120 mA
- D. 180 mA

A

Worked solution

Since the voltage drop across the Zener diode will be $6.0\ \text{V}$, the voltage across the resistor R_1 is $3.0\ \text{V}$. Hence, the current through the resistor is $I = \frac{V}{R} = \frac{3}{100} = 30\ \text{mA}$.

Question 9

The current in the Zener diode is measured as $25\ \text{mA}$. What is the current in the load resistor?

- A. 60 mA
- B. 35 mA
- C. 15 mA
- D. 5 mA

D

Worked solution

Current in the load resistor is = current in the resistor R_1 – current in the Zener diode
 $= 30 - 25\ \text{mA} = 5\ \text{mA}$

Question 10

As the supply voltage reduces from 9.0 V to 8.0 V, which one of the following **best describes** the current in the resistor R_1 ?

- A. The current will rise.
- B. The current will reduce.**
- C. The current will stay the same.
- D. No current will flow through the resistor.

B

Worked solution

The voltage drop across the Zener diode will stay the same at 6.0 V. Therefore, the voltage across the resistor will decrease, which will decrease the current through the resistor.

Question 11

The capacitor is now replaced with one that has a higher capacitance of 2500 μF . In comparison to the original voltage across points P and Q , which of the following best describes the new effect on the voltage across P and Q ?

- A. More smoothing will occur and the ripple voltage will be higher.
- B. There will be no difference from the original voltage.
- C. More smoothing will occur and the ripple voltage will be lower.
- D. There will be more smoothing, less ripple voltage and the peak voltage will be slightly lower.**

D

Worked solution

A higher capacitor will result in more smoothing, which will lower the ripple voltage. However, a small reduction in peak voltage will also occur.

Tips

- *The current through the resistor will be affected by the voltage drop across it.*
- *The voltage across the Zener diode is stable for reasonable fluctuations in power supply.*
- *The current in the main circuit is divided into current through the Zener diode and other resistors. Current balance laws of parallel circuits will apply.*

The following information relates to Questions 12 and 13.

Two resistors of magnitude $2500\ \Omega$ and $7500\ \Omega$ are connected to a commercial voltage regulator, as shown in Figure 5. A $12.0\ \text{V}$ unregulated power supply is used and the voltage regulator has an output of $9.0\ \text{V}$.

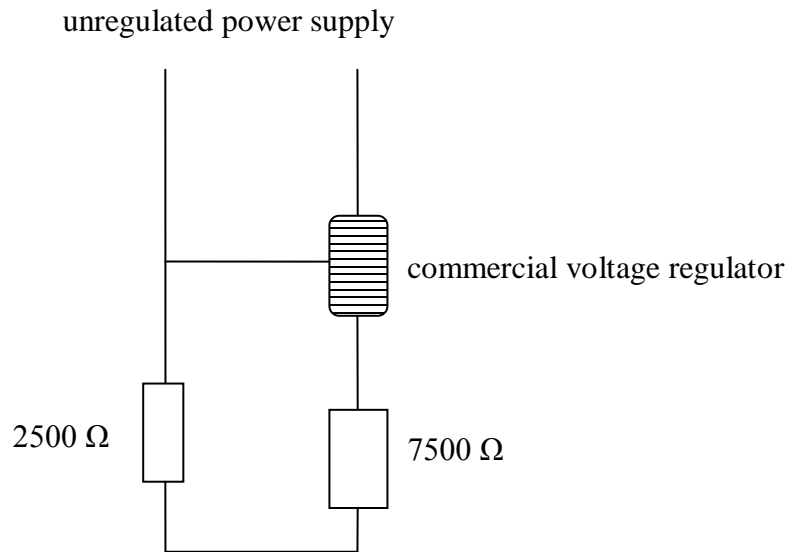

Figure 5

Question 12

The current in the $7500\ \Omega$ resistor is about

- A. $2.4\ \text{mA}$
- B. $1.2\ \text{mA}$
- C. $0.9\ \text{mA}$
- D. $0.6\ \text{mA}$

A

Worked solution

The voltage drop across the $7500\ \Omega$ resistor will be $\frac{3}{4} \times 9 = 6.75\ \text{V}$.

Therefore, the current is $I = \frac{V}{R} = \frac{6.75}{7500} = 0.9\ \text{mA}$.

Hence, correct answer is C.

Question 13

The power loss in the 2500 Ω resistor is closest in value to

- A. 2.0 mW
- B. 3.0 mW
- C. 5.0 mW
- D. 8.0 mW

A

Worked solution

Voltage drop across the 2500 Ω resistor is $\frac{9}{4} = 2.25$ V.

Therefore, power loss = $\frac{V^2}{R} = \frac{2.25^2}{2500} = 2.02$ mW .

Hence, closest answer is A.

Tips

- *A commercial voltage regulator will give a fixed (regulated) voltage supply provided that the input voltage is not beyond range of use.*
- *Ohm's law based solution of series and parallel circuits are best solved methodically.*