



THE SCHOOL FOR EXCELLENCE (TSFX)

UNIT 3 PHYSICS 2009

WRITTEN EXAMINATION 1

Reading Time: 15 minutes
Writing Time: 1 hour 30 minutes

QUESTION AND ANSWER BOOK

Structure of Book

<i>Section</i>	<i>Number of Questions</i>	<i>Number of Questions to be Answered</i>	<i>Number of Marks</i>
A	Core Studies		
	Motion	15	36
	Electronics and Photonics	14	28
B	Detailed Studies		
	1. Einstein's Special Relativity OR	13	26
	2. Further Electronics OR	13	26
	3. Structures and Materials	13	26
			Total 90

COMPLIMENTS OF THE SCHOOL FOR EXCELLENCE

Voted Number One For Excellence and Quality in VCE Programs and Tutorials.



THE SCHOOL FOR EXCELLENCE (TSFX)

The School For Excellence (**TSFX**) is a private educational institution that provides educational services to Year 11 and 12 students out of school hours. Our services include intense revision courses before examinations, intense weekly tuition classes, study skills lectures, as well as specialised courses that prepare students in advance of each school term.

The educational programs conducted by **TSFX** are widely recognised for providing the highest quality programs in Victoria today. Our programs are the result of more than 15 years of collaborative effort and expertise from dozens of teachers and schools across the state, ensuring the highest possible quality resources and teaching styles for VCE students.

For additional information, join our complimentary mailing list at www.tsfx.com.au. Alternatively, please call **TSFX** on (03) 9663 3311 during business hours.

FREE VCE RESOURCES AT VCEDGE ONLINE

VCEdge Online is an educational resource designed to provide students the best opportunities to optimise their Year 11 or 12 scores. **VCEdge Online** members receive over \$300 worth of resources at no charge, including:

- Subject notes and course summaries.
- Sample A+ SACS and SATS.
- Trial examinations with worked solutions.
- Weekly study tips and exam advice (in the weeks leading up to the examinations)
- Two **FREE** tickets into an intense examination strategy lecture (valued at \$200!!!).
- Cheat sheets and formula cards.
- Critical VCE updates.
- Free VCE newsletters.
- Information on upcoming educational events.
- And much, much more!!!

JOIN FREE OF CHARGE AT WWW.TSFX.COM.AU

SECTION A – CORE STUDIES

Instructions For Section A

Answer **all** questions for **both** Areas of Study in this section of the paper.

You should take the value of g to be 10 ms^{-2} .

Unless stated otherwise, ignore air resistance.

AREA OF STUDY 1: MOTION IN ONE AND TWO DIMENSIONS

Questions 1 to 3 refer to the following information

A volleyball (mass = 0.225 kg) is hit very high in the air such that it returns vertically to earth and has reached a terminal velocity of 28.0 m/s downwards.



QUESTION 1

What is the magnitude and direction of the force of air resistance against the volleyball at this time?

N	direction:
----------	-------------------

3 marks

The volleyball is struck by a person with an impulse on the ball of 13.5 Ns upwards.

QUESTION 2

If the duration of the impact was 0.25 s, what was the average force of the person on the ball?

N	direction:
----------	-------------------

3 marks

QUESTION 3

With what velocity does the ball leave the person?

m/s	direction:
------------	-------------------

3 marks

QUESTION 4

Which one of the following is the **worst** representation of Newton's First Law; the Law of inertia?

- A. An object maintains its state of motion unless acted on by an unbalanced force.
- B. An object maintains its velocity unless acted on by an unbalanced force.
- C. An object maintains its speed unless acted on by an unbalanced force.
- D. An object maintains its momentum unless acted on by an unbalanced force.
- E. An object maintains its inertia unless acted on by an unbalanced force.

2 marks

Questions 5 and 6 refer to the following information:

A small 24 g stone is placed on a fast moving circular turntable at a point 8 cm from the centre, as illustrated in Figure 1. It is moving with a speed of 50 m/s.

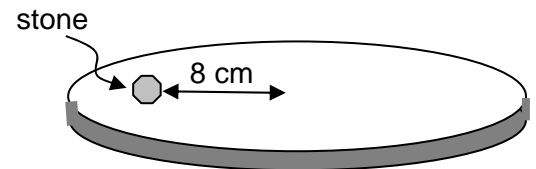

Figure 1

QUESTION 5

What is the magnitude of the frictional force holding the stone in its motion?

2 marks

QUESTION 6

The speed of the turntable is increased fairly rapidly and the stone (st) leaves its circular path. Which of the arrows **A - D** in Figure 2 indicates the most likely path of the stone as it leaves the turntable, as viewed from above?

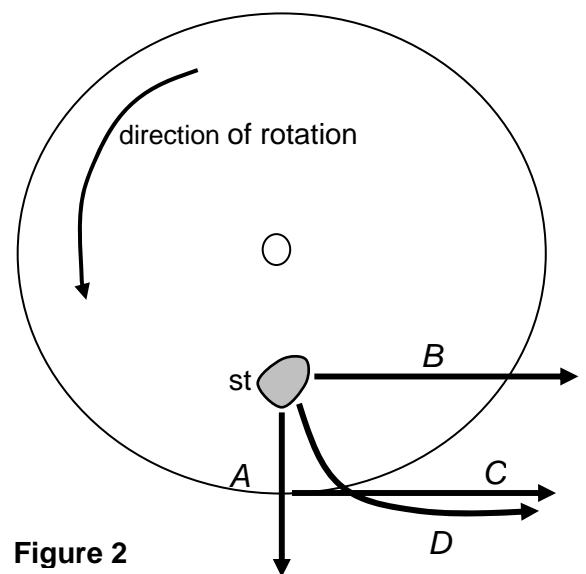

Figure 2

2 marks

QUESTION 7

Andrew, Betty and Charles are discussing the size of the earth's gravitational field at an **altitude** equal to the earth's radius (R_E), as illustrated in Figure 3.

Andrew says that the gravitational field strength due to the Earth at this point will be 2.45 N/kg. Betty argues that it will be 4.9 N/kg and Charles is very confident that $g = 9.8$ N/kg at this altitude.

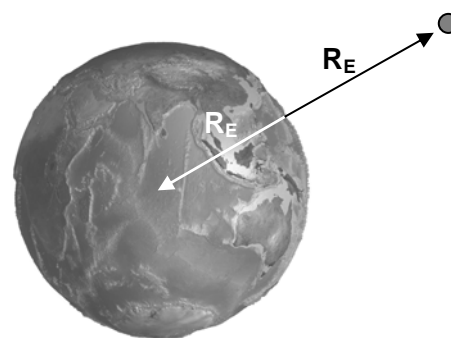

Figure 3

Explain who is correct and why?

2 marks

Questions 8 to 10 refer to the following information:

In attempting to jump from one ramp to another a skater moving at 4.8 m/s attempts to clear a gap of 2.0 metres. The take-off angle is of 28° elevation. For questions 8 & 9 assume air resistance is negligible.



Figure 4

QUESTION 8

After leaving the first ramp, what time does it take for the skater to reach the highest point in his flight?

3 marks

QUESTION 9

Does the skater land on the other ramp? Show your calculations and reasoning.

3 marks

QUESTION 10

When positioned as in Figure 4, which of the vectors (**A – D**) represents the direction of the net force acting on the skater at this time? (Air resistance must be included for consideration).

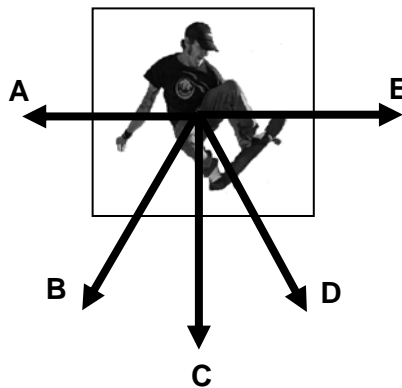

2 marks

Questions 11 to 13 refer to the following information:

The Asteroid Research Spacecraft (ARS) has been launched and will orbit the asteroid Skradgit whose mass is very much less than that of earth.

QUESTION 11

Which one of the statements A to D best describes how the period of the spacecraft in orbit around Skradgit would compare with the period of an Earth satellite with the same orbital radius?

- A. The period around the asteroid would be greater than for the Earth satellite.
- B. The period around the asteroid would be less than for the Earth satellite.
- C. The period would be the same.
- D. There is insufficient information to decide.

2 marks

QUESTION 12

Explain your answer to Question 11.

2 marks

The mass of the asteroid Skradgit is found to be 1.2×10^{21} kg and the ARS spacecraft has an orbital radius of only 3.5×10^5 m.

QUESTION 13

Calculate the speed of the ARS spacecraft.

3 marks

Questions 14 to 15 refer to the following information:

A dog (mass = 14 kg) runs in a northerly direction across a beach with a speed of 3.0 m/s and turns to run to the west at 3.0 m/s.

QUESTION 14

What is the magnitude and direction of the change of velocity of the dog?

m/s	direction:
-----	------------

2 marks

QUESTION 15

What is the magnitude and direction of the impulse on the dog due to the sand?

kgm/s	direction:
-------	------------

2 marks

End of Section on Motion in One and Two Dimensions

AREA OF STUDY 2: ELECTRONICS AND PHOTONICS

Questions 1 to 5 refer to the following information:

Four identical globes with resistance $30\ \Omega$ are connected to a $12\ \text{V}$ battery as shown in Figure 1 below.

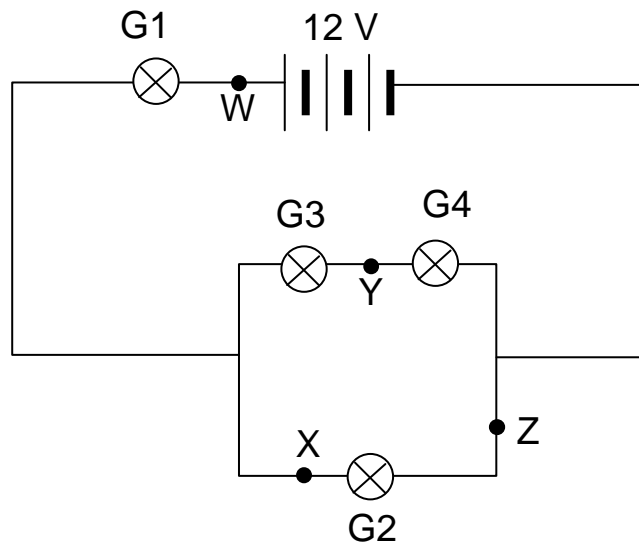

Figure 1

QUESTION 1

Determine the total resistance for the circuit in Figure 1.

 Ω

3 marks

QUESTION 2

Determine the current produced by the battery.

 A

2 marks

QUESTION 3

Which globe(s) will glow the brightest? Explain your answer.

Globe:

3 marks

QUESTION 4

At which point (W, X, Y, Z) would you place an *open* switch to increase the brightness of globe G₂?

- A. W
- B. X
- C. Y
- D. Z

2 marks

QUESTION 5

At which point (W, X, Y, Z) would you place an *ammeter* to confirm your answer to Question 2?

- A. W
- B. X
- C. Y
- D. Z

2 marks

Questions 6 to 9 refer to the following information:

Jo and Peter are designing a circuit to function as a thermostat. Their circuit will consist of a thermistor, an LED and a variable voltage supply, V_s , as shown in Figure 2.

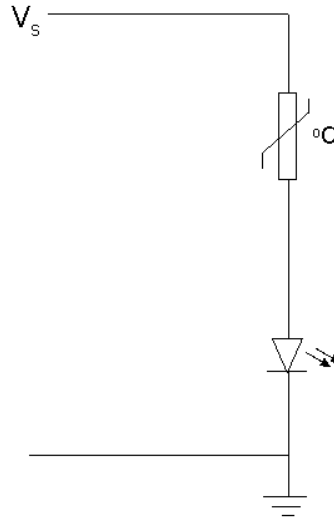

Figure 2

The characteristic curves for the thermistor and the LED are shown in Figures 3 and 4 respectively.

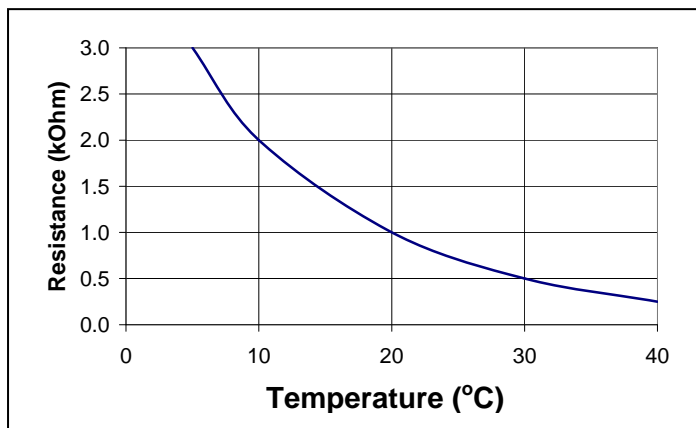

Figure 3

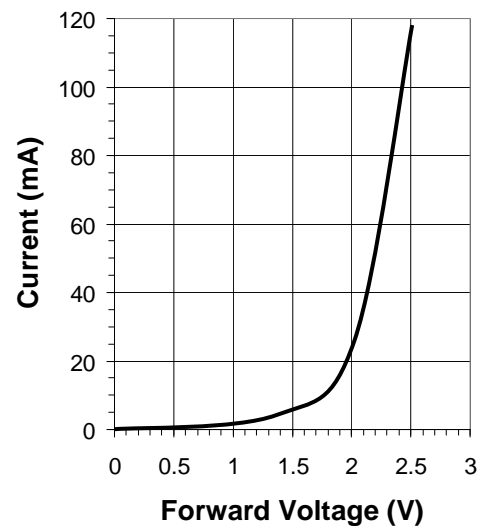

Figure 4

QUESTION 6

Determine the resistance of the thermistor in Ω when the temperature is 20°C .

1 mark

QUESTION 7

Determine the threshold voltage for the LED.

1 mark

Jo and Peter would like the LED to produce enough light for a photodiode to switch on a heater when the temperature is below 20°C . The LED will glow brightly enough when the current is 10mA .

QUESTION 8

Determine the supply voltage required for the LED to indicate when the temperature is 20°C .

2 marks

QUESTION 9

Will Jo and Peter's circuit work as they intended? *Provide reasons for your answer.*

3 marks

Questions 10 to 13 refer to the following information:

A state of the art audio system is to be set up in the music classroom. The system will be wired using optical cabling. The block diagram in Figure 5 shows the arrangement of the devices and the electrical components enabling the signal from a microphone to be sent to and amplified for a set of speakers.

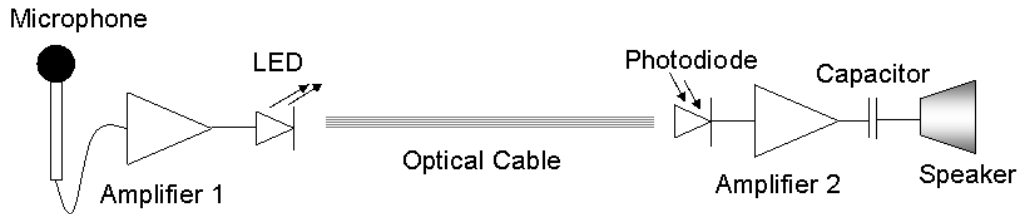

Figure 5

QUESTION 10

Which of the following components (A-D) shows where light intensity modulation occurs in the system described in Figure 5?

Modulation

- A. Microphone
- B. LED
- C. Photodiode
- D. Amplifier 1

2 marks

Amplifier 2 has the following transfer characteristics shown in Figure 6.

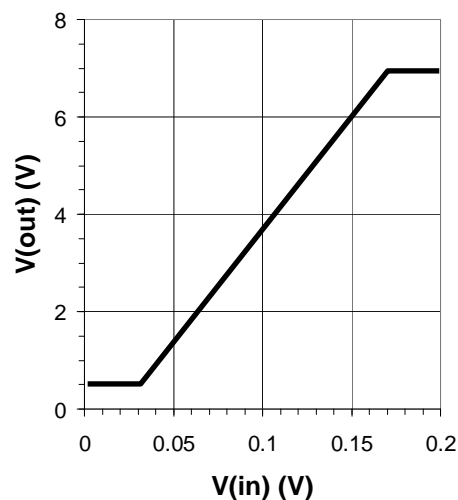

Figure 6

QUESTION 11

Is Amplifier 2 an inverting or non-inverting amplifier?

1 mark

QUESTION 12

Determine the voltage gain of Amplifier 2.

2 marks

The following input signal enters amplifier 2.

Figure 7

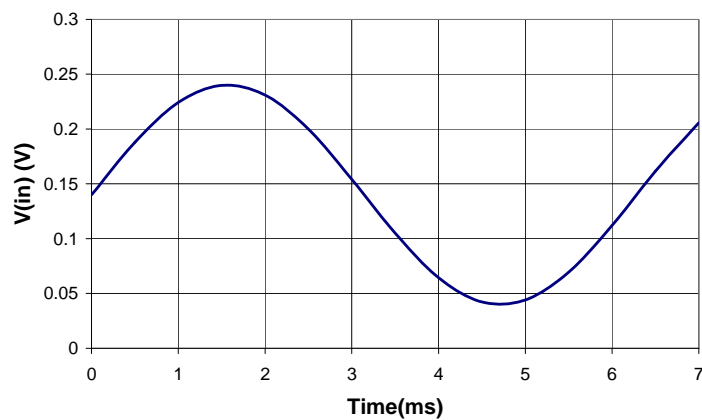

QUESTION 13

On the axes below, sketch the corresponding output voltage of amplifier 2. Clearly label the vertical axis.

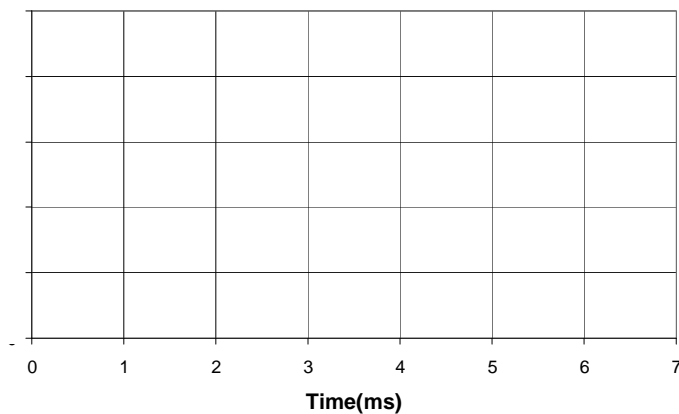

3 marks

QUESTION 14

The photodiode receiving the light signal from the optical fibres has the following I-V curve.

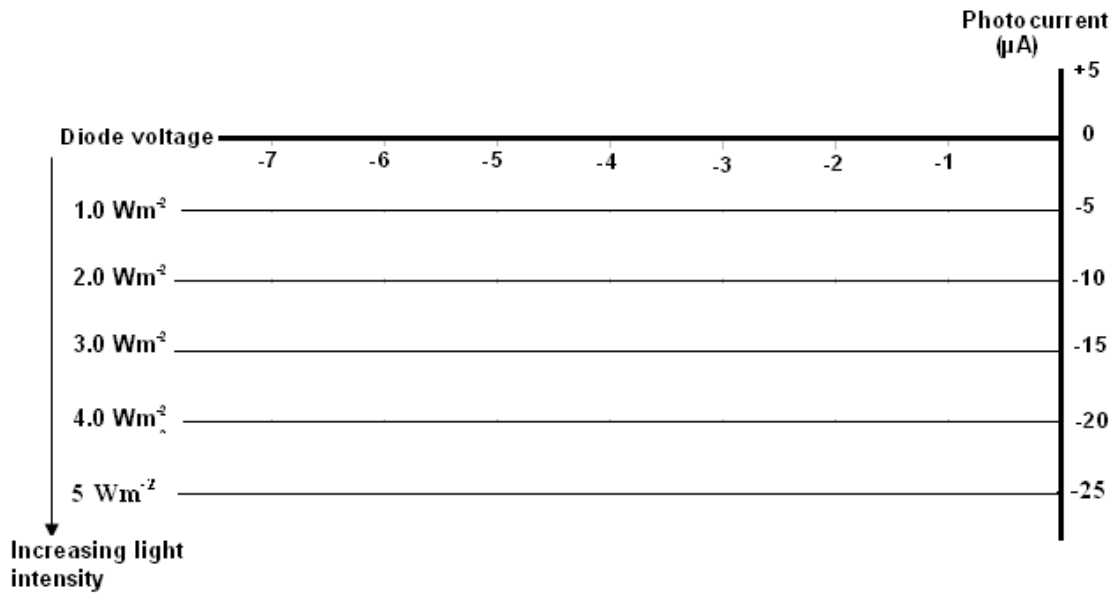

Figure 8

What is the photocurrent produced by the photodiode when a light intensity of 4.0 Wm^{-2} is produced by the optical cables?

μA

1 mark

End of Electronics and Photonics Section

SECTION B – DETAILED STUDIES

Instructions For Section B

Choose one of the following **Detailed Studies**. Answer all the questions on the **Detailed Study** you have chosen.

DETAILED STUDY 1 – EINSTEIN'S SPECIAL RELATIVITY

QUESTION 1

A frame of reference described as 'an inertial reference frame' is one that

- A. must always be stationary.
- B. is not accelerating.
- C. is undergoing constant non-zero acceleration.
- D. is moving with a known velocity.

2 marks

QUESTION 2

Galileo's postulate implies that:

- A. a stationary observer will observe all inertial frames the same.
- B. all inertial frames of reference are unique.
- C. all velocities are relative to the observer.
- D. time passes at different rates that depend on the speed of the observer.

2 marks

The following information refers to Questions 3 to 5:

Imagine a train of proper length 100 m passing through a station at half the speed of light. There are two lightning strikes, one at the front and one at the rear of the train, **leaving scorch marks on both the train and the station platform**. Observer X is standing on the station platform midway between the two strikes, while observer Y is sitting in the middle of the train. Light from each strike travels to both observers.

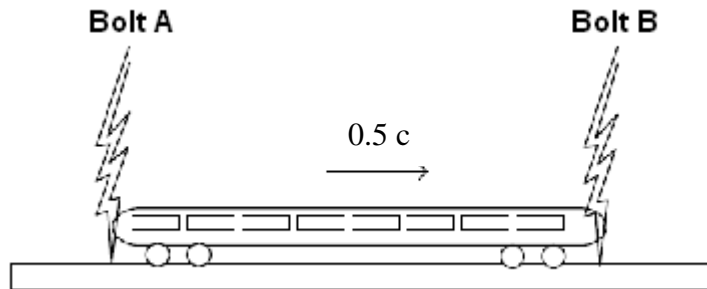

QUESTION 3

If observer X on the station concludes from his observations that the two lightning strikes occurred simultaneously, what would observer Y on the train see?

- A. Observer Y would observe Bolt A first.
- B. Observer Y would observe both Bolts at the same time.
- C. Observer Y would observe Bolt B first.
- D. Observer Y is going so fast no bolts of lightning will be observed.

2 marks

QUESTION 4

What will be the distance between the scorch marks on the *train*, according to X?

- A. 76
- B. 87m
- C. 100m
- D. 115m

2 marks

QUESTION 5

What will be the distance between the scorch marks on the *platform*, according to Y?

- A. 76
- B. 87m
- C. 100m
- D. 115m

2 marks

QUESTION 6

George is moving with uniform velocity of $0.9c$ relative to Wendy. They are each wearing a wristwatch with a second hand that takes one minute to make one complete revolution. When George observes the second hand on his watch to have made one complete revolution, how many revolutions will Wendy observe the second hand of her watch to have made?

- A. 0.43
- B. 0.9
- C. 1.0
- D. 2.3

2 marks

QUESTION 7

Muons have a half-life of 3.1×10^{-6} s as measured in a reference frame in which the muons are at rest. Suppose an accelerator creates a pulse of muons moving with a speed of $0.9c$. How far will the pulse have travelled as measured by a laboratory observer when half the muons in the pulse will have decayed?
($c = 3.0 \times 10^8 \text{ ms}^{-1}$)

- A. 835
- B. 930
- C. 1920
- D. 2130

2 marks

The following information refers to Questions 8 and 9:

When electrons are accelerated through a potential difference of 1.50×10^6 V, they attain a speed of $0.97c$ relative to the laboratory. The rest mass of an electron is 9.1×10^{-31} kg.

QUESTION 8

Determine the mass of the electron at this speed.

- A. 9.1×10^{-31} kg
- B. 9.4×10^{-30} kg
- C. 3.7×10^{-30} kg
- D. 3.9×10^{-30} kg

2 marks

QUESTION 9

Determine its kinetic energy at this speed.

- A. 1.02×10^{-13} J
- B. 1.56×10^{-13} J
- C. 2.51×10^{-13} J
- D. 3.36×10^{-13} J

2 marks

QUESTION 10

Relativistic momentum is:

- A. equal to the internal change in an object's motion.
- B. dependent on the relativistic mass and velocity of the object.
- C. dependent only to an object's relative mass.
- D. a fixed quantity related to the rest conditions of the object.

2 marks

QUESTION 11

In the Michelson-Morley experiment an interferometer is used in which a beam of light is split into two beams. These travel along different paths and are then recombined and interfere and so form interference fringes. The diagram below shows the main features of such an interferometer.

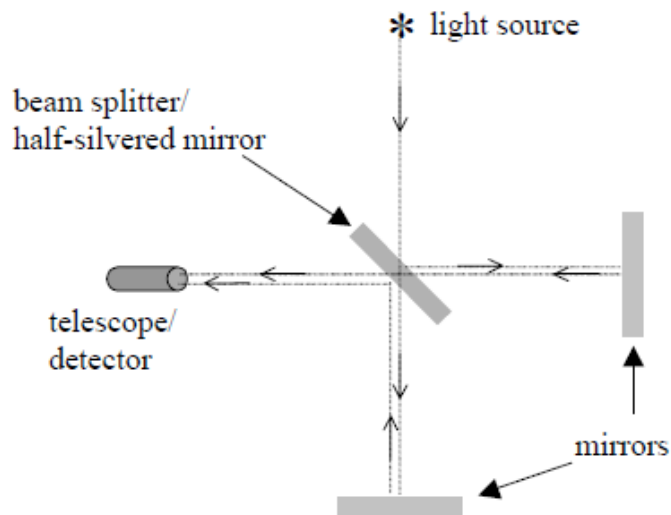

What did the results of the experiment indicate?

- A. No detectable velocity difference from light reflecting off each mirror.
- B. Speed of light is affected by the speed of the light source.
- C. A changing interference fringe pattern was observed when the interferometer is rotated.
- D. At different times of the year the Earth travels in different directions.

2 marks

The following information refers to Questions 12 and 13:

Suppose that some time in the future it will be possible for astronauts to travel to a distant star system 8.4 light years away, at a constant speed of $0.95c$.

QUESTION 12

How many years would it take for the astronauts to get there as measured by observers in the Earth's frame of reference?

- A. 8.84 years
- B. 8.4 years
- C. 2.8 years
- D. 1.4 years

2 marks

QUESTION 13

On arrival at the star system they immediately set out on the return journey, at the same speed. On their arrival back on Earth how many years have passed, since the astronauts first left Earth, **as measured by the astronauts?**

- A. 2.8 years
- B. 5.6 years
- C. 16.8 years
- D. 17.7 years

2 marks

End of Einstein's Special Relativity Section

DETAILED STUDY 2 – FURTHER ELECTRONICS

The circuit in Figure 1 has a capacitor whose state of charge can be determined by the position of switches S1 and S2.

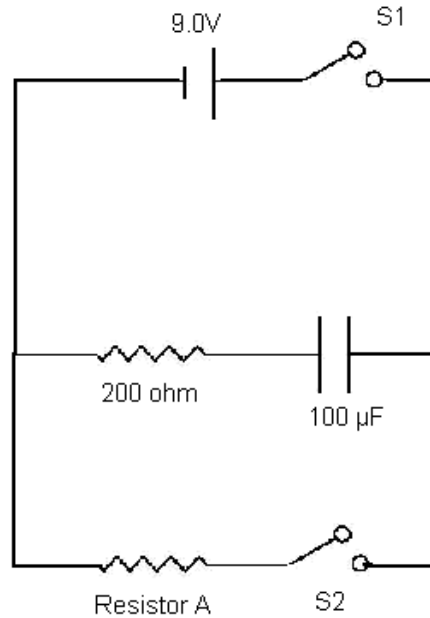

Figure 1

When switch S1 closes the $100\mu\text{F}$ capacitor charges. After a period of time in which the capacitor has fully charged, S1 opens and S2 closes causing the capacitor to discharge through resistor A.

QUESTION 1

What is the time constant for the charging of the capacitor?

- A. 10 ms
- B. 20 ms
- C. 100 ms
- D. 200ms

2 marks

The graph in Figure 2 represents the discharge characteristics of the capacitor when switch S2 closes.

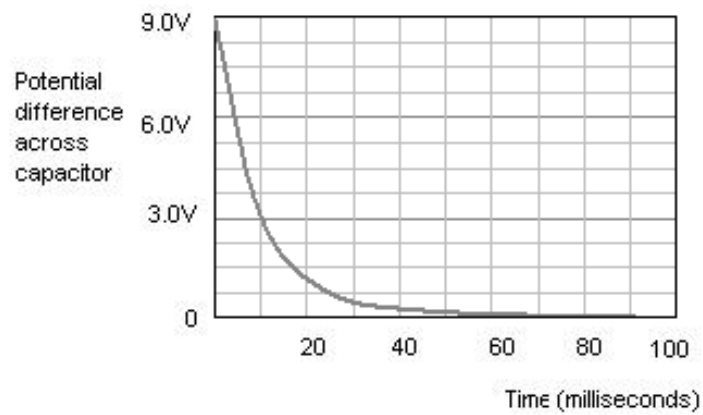

Figure 2

QUESTION 2

The value of resistor A is best represented by:

- A. 100Ω
- B. 200Ω
- C. 500Ω
- D. 1000Ω

2 marks

The following information applies to Questions 3 and 4:

In the circuit in Figure 3, a resistor is connected to an AC power supply through a single power diode. Leads of a cathode ray oscilloscope are connected to each side of the resistor at points A and B.

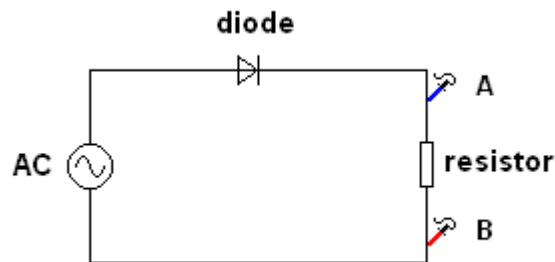

Figure 3

The following graphs in Figure 4 represent a range of possible displays on the screen of the cathode ray oscilloscope.

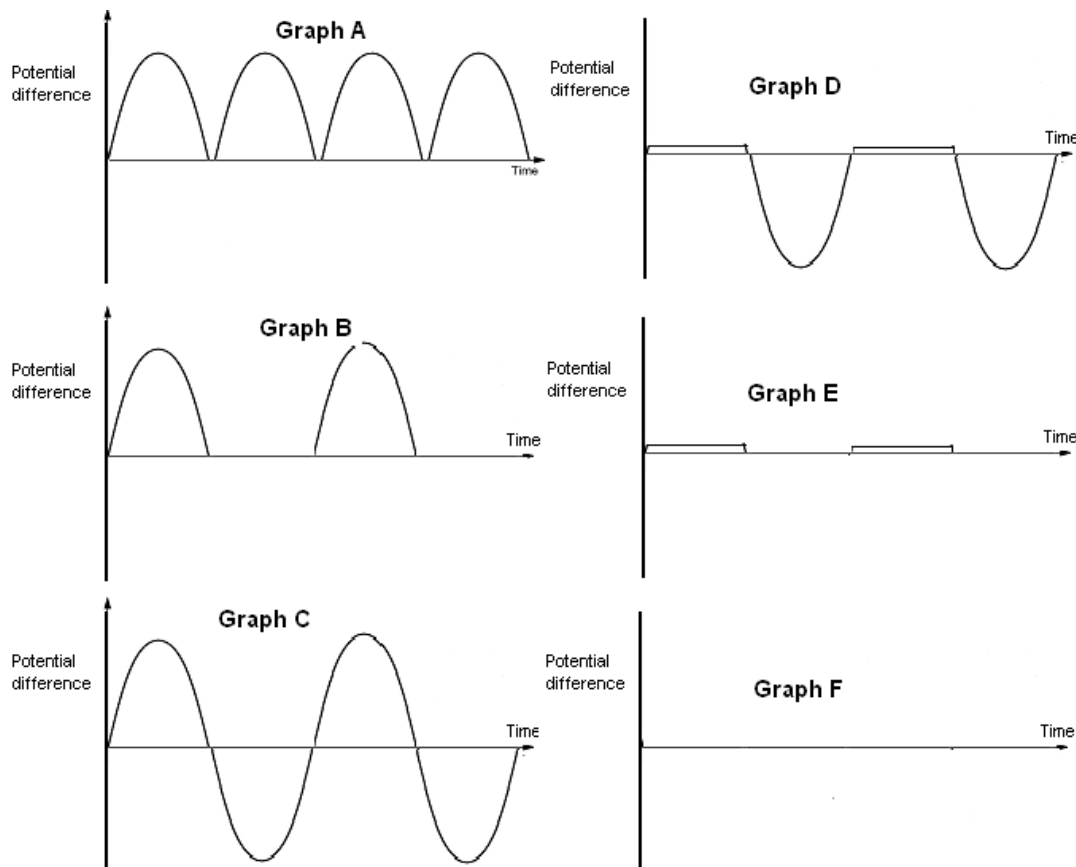

Figure 4

QUESTION 3

Which graph best represents the display on the cathode ray oscilloscope?

- A. Graph A
- B. Graph B
- C. Graph C
- D. Graph D
- E. Graph E
- F. Graph F

2 marks

QUESTION 4

The connections to the cathode ray oscilloscope are now moved to positions C and D.

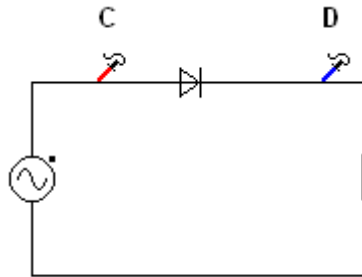

Which graph best represents the time varying voltage that is likely to be viewed on the screen?

- A. Graph A
- B. Graph B
- C. Graph C
- D. Graph D
- E. Graph E
- F. Graph F

2 marks

QUESTION 5

The circuit in Figure 5 is a voltage divider power supply that can be used to provide a DC voltage (V_{OUT}) to a LOAD.

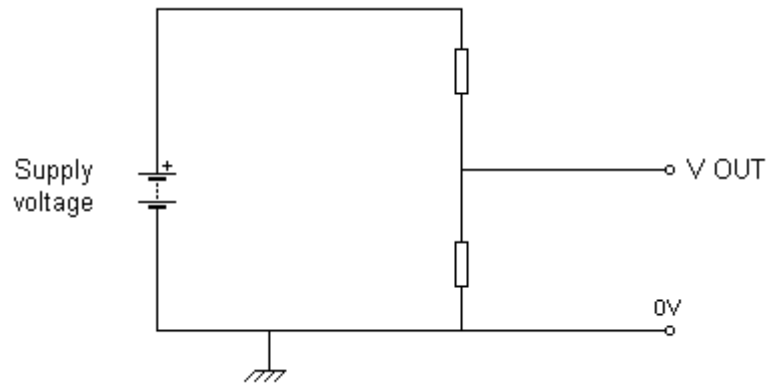

Figure 5

Select the alternative which best describes this circuit.

- A. A regulated power supply because it can provide a DC voltage to the load at a value less than the supply voltage.
- B. A regulated power supply because it can provide a constant DC voltage to a load.
- C. An unregulated power supply because if the load resistance changes the value of V_{OUT} also changes.
- D. An unregulated power supply because the supply to the voltage divider is DC.

2 marks

QUESTION 6

The circuits in Figure 6 are attempts by a student to develop a full-wave rectified voltage supply to a resistor.

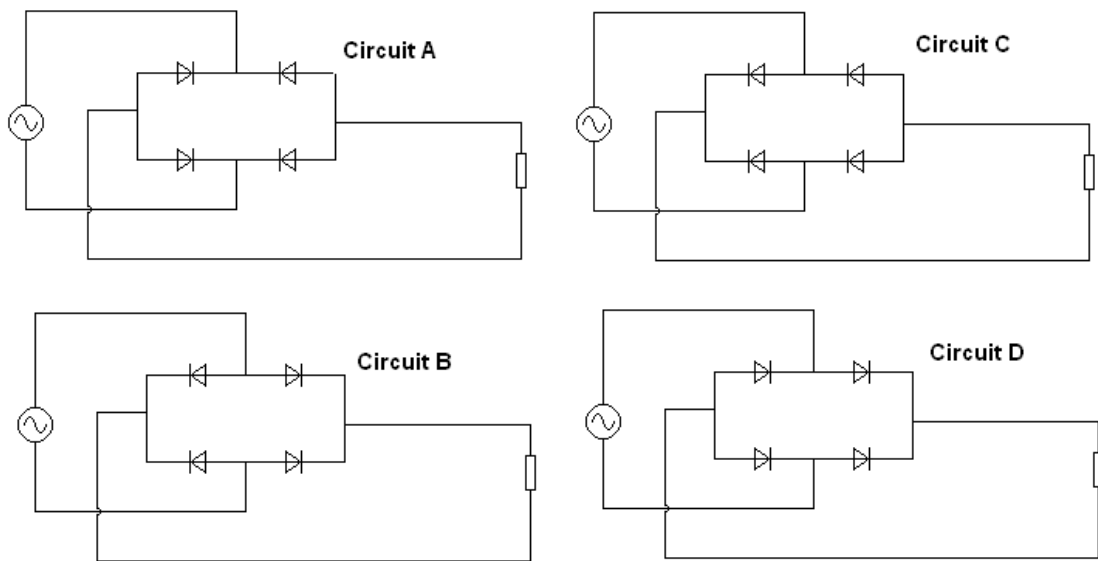

Figure 6

Choose the alternative that best indicates the full selection of successful circuits.

- A. Circuit A only
- B. Circuit B only
- C. Circuit C only
- D. Circuit D only
- E. Circuits B and D
- F. Circuits A and C
- G. Circuits C and D
- H. All of the above circuits

2 marks

QUESTION 7

A $100\mu\text{F}$ smoothing capacitor is used to reduce the ripple voltage in a full-wave rectified power supply to an ohmic load.

It was decided to operate a second identical load from the power supply as follows:

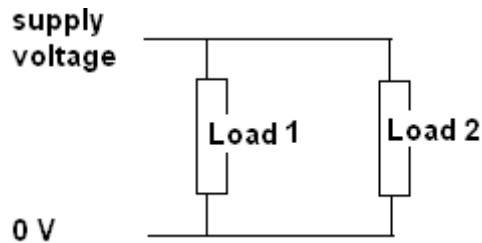

The ripple voltage with the second LOAD installed is likely to be about

- A. Half the original value.
- B. The same as the original value.
- C. Twice the original.
- D. No ripple voltage.

2 marks

QUESTION 8

The second LOAD was removed AND an additional two capacitors of the same value were added in parallel to the original:

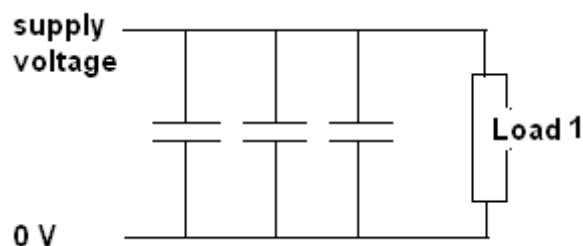

Compared to the original peak-to-peak ripple voltage, it is now approximately

- A. A third of the original ripple.
- B. Two thirds of the original ripple.
- C. The same as the original ripple.
- D. Three times the original ripple.

2 marks

The following information refers to Questions 9 and 10:

The smoothed full-wave rectified voltage supplied to the input of a 6V IC voltage regulator (7806) is shown below in Figure 7. The voltage regulator has a 3.0V dropout zone requiring it to receive a minimum input of 9.0V. The smoothed voltage supply has a peak-to-peak variation of 2.0 volts and a peak of 12V. The LOAD has a resistance of 120 ohms.

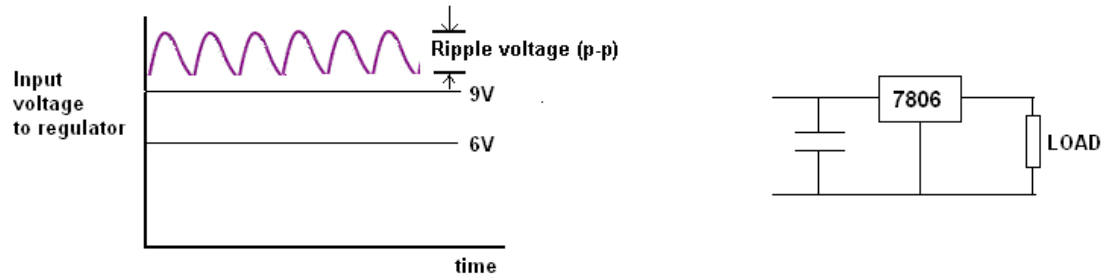

Figure 7

QUESTION 9

Which of the following best represents the power dissipated across the 7806 voltage regulator?

- A. 0.25W
- B. 0.30W
- C. 0.50W
- D. 0.60W

2 marks

QUESTION 10

The LOAD is changed for another resulting in the peak-to-peak ripple voltage increasing to 4.0V. The peak voltage remains at 12V.

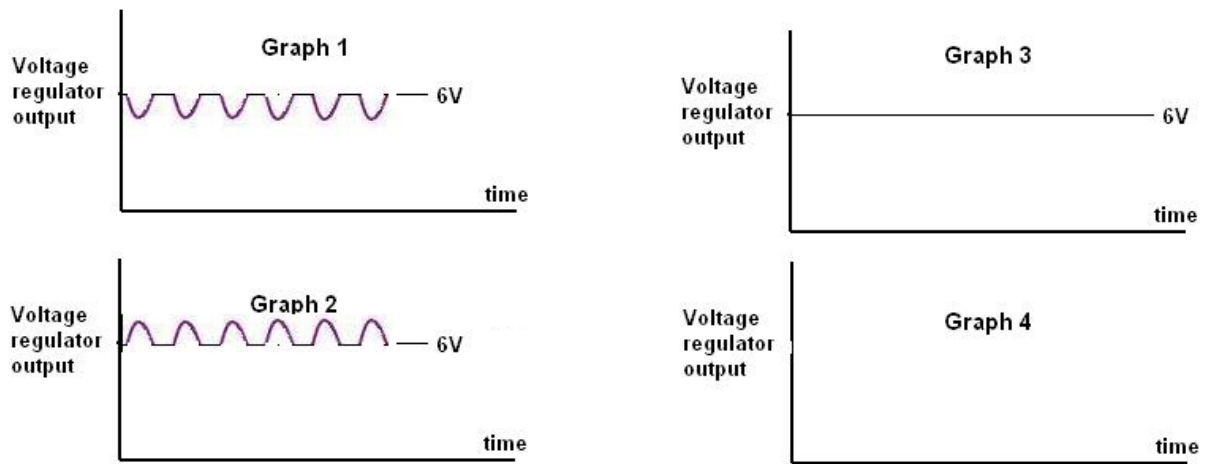

Figure 8

Which of the graphs shown in Figure 8 best represents the output of the voltage regulator now?

- A. Graph 1
- B. Graph 2
- C. Graph 3
- D. Graph 4

2 marks

The following information applies to Questions 11 to 13:

The circuit in Figure 9 uses a 6.0V zener diode to maintain a constant potential difference across a number of 300 ohm resistors. Switches 1 and 2 control current to the resistors. The zener has a power rating of 0.3W.

Figure 9

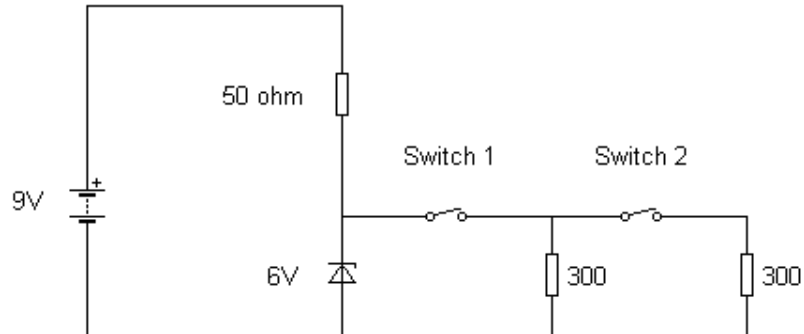

QUESTION 11

When switch 1 is closed and switch 2 open, what current flows through the zener diode?

- A. 0.06A
- B. 0.04A
- C. 0.02A
- D. zero

2 marks

QUESTION 12

Closing switch 2 so that both 300Ω resistors are connected causes current through the zener diode to:

- A. Increase
- B. Decrease
- C. Remain the same

2 marks

QUESTION 13

Select the best alternative from the options below. When switch 1 opens,

- A. The zener diode burns out.
- B. The current through the 50 ohm resistor reduces.
- C. The current through the 50 ohm resistor increases.
- D. The zener diode switches off.

2 marks

End of Further Electronics Section

DETAILED STUDY 3: MATERIALS AND STRUCTURES

Questions 1 to 5 refer to the following information:

The stress-strain graph in Figure 1 shows the properties of four materials.

Figure 1

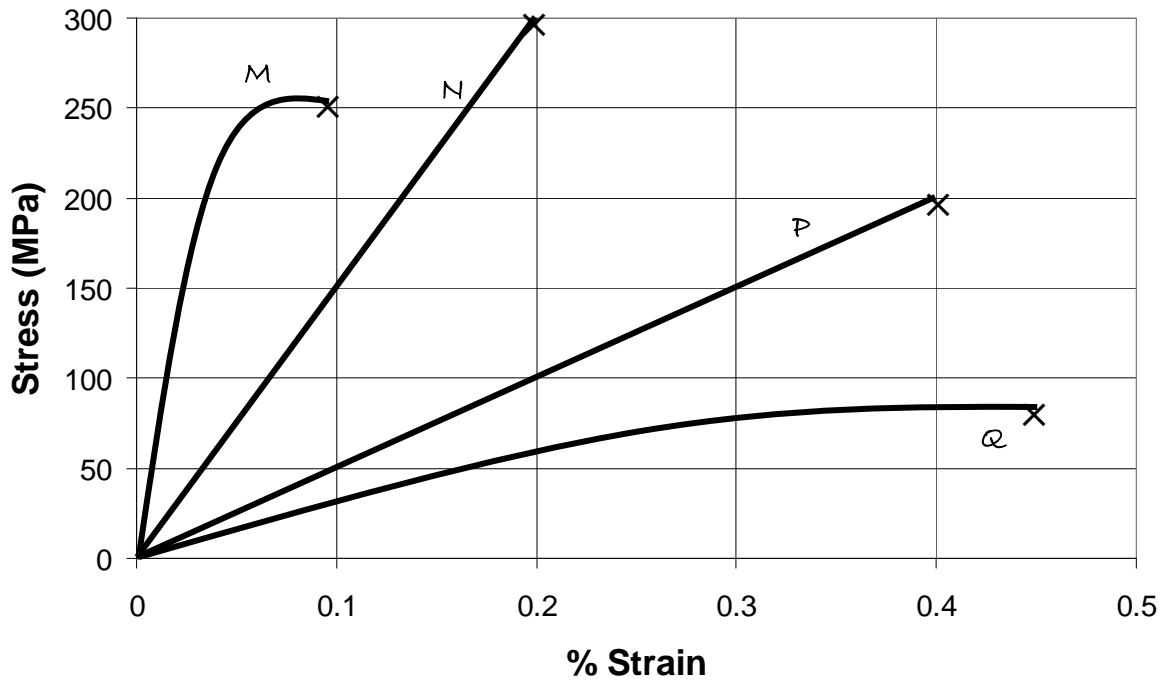

QUESTION 1

Which of the four materials (A-D) has the greatest strength?

- A. M
- B. N
- C. P
- D. Q

2 marks

QUESTION 2

Which of the following properties (A-D) is true for material M?

- A. stiffest
- B. strongest
- C. largest strain energy
- D. toughest

2 marks

QUESTION 3

Which of the following quantities (A-D) best represents the energy per unit volume to fracture for material N?

- A. 30 J/m³
- B. 300 J/m³
- C. 300 kJ/m³
- D. 30 MJ/m³

2 marks

QUESTION 4

Which of the four materials (A-D) is the most brittle?

- A. M
- B. N
- C. P
- D. Q

2 marks

QUESTION 5

Which of the four quantities (A-D) best estimates the value of Young's Modulus for Material P?

- A. 500 Pa
- B. 500 kPa
- C. 500 MPa
- D. 50 GPa

2 marks

Questions 6 to 9 refer to the following information:

A balcony floor made of concrete is supported at the wall and by a support pillar 2 m from the wall. The balcony floor is 3 m wide as shown in Figure 2. Jeff is standing at the centre of the balcony floor. Jeff has a mass of 65 kg and the concrete floor has a mass of 200 kg.

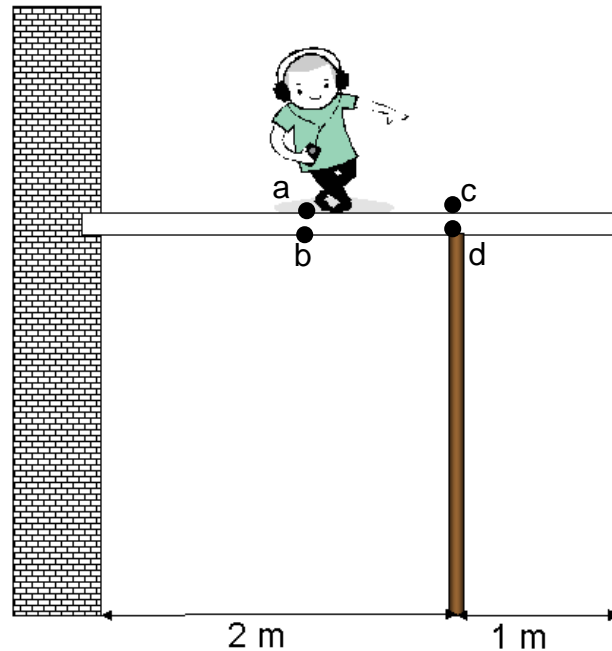

Figure 2

QUESTION 6

Which one or more of the following positions indicated by the dots in Figure 2, (A-D) would be the best place to reinforce the balcony floor with steel mesh?

- A. a
- B. b
- C. c
- D. d

2 marks

Jeff now walks to the end of the balcony. The balcony is in static equilibrium.

QUESTION 7

Which of the following types of forces (A-D) best describes the force at point d?

- A. shear
- B. compression
- C. tensile
- D. gravitational

2 marks

QUESTION 8

Which of the following quantities (A-D) best estimates the force from the supporting pillar on the balcony floor?

- A. 248 N
- B. 265 N
- C. 2475 N
- D. 2650 N

2 marks

QUESTION 9

Which of the following quantities (A-D) best estimates the force acting on the balcony from the wall?

- A. 0 N
- B. 175 N
- C. 1750 N
- D. 2650 N

2 marks

Questions 10 to 13 refer to the following information:

A steel cable has a Young's Modulus of 200 GPa. The cable has a cross-sectional area of 100 mm^2 and is 50 m long. The cable is then stretched such that its length is now 50.05 m.

QUESTION 10

Which of the following quantities (A-D) best estimates the % strain of the cable?

- A. 0.0001
- B. 0.001
- C. 0.099
- D. 0.1

2 marks

The cable is now stretched further and experiences a stress of 500 MPa.

QUESTION 11

Which of the following quantities (A-D) best estimates the net force on the cable?

- A. 50 N
- B. 50×10^3 N
- C. 50×10^6 N
- D. 50×10^9 N

2 marks

QUESTION 12

Which of the following quantities (A-D) represents the new strain experienced by the steel cable?

- A. 0.0025
- B. 0.25
- C. 2.5
- D. 1×10^5

2 marks

QUESTION 13

Which of the following statements (A-D) best describes why steel is used for cabling rather than aluminium which has a Young's modulus of 70 GPa?

- A. Steel is not a composite material
- B. Steel is more elastic
- C. Steel is less brittle
- D. Steel is stiffer

2 marks

End of Structures and Materials Section