



VCE PHYSICS 2009

YEAR 12 TRIAL EXAM UNIT 4

CONDITION OF SALE:

© Limited copyright. This paper may be photocopied without charge for use only within the school that has purchased the material. Our electronic copy only may be placed on the school intranet for exclusive use by the teachers and students of the school that has purchased the material. They may **not** otherwise be reproduced (all or part) electronically, scanned into a school computer, forwarded via email, or placed on the Internet, without written consent of the publisher.

Reading Time: 15 minutes

Writing Time: 1h 30m

Structure of Booklet

Section	No of Questions	No of Questions to be answered	No of Marks
A. Core Area of Study			
1. Electric Power.	17	17	38
2. Interactions of Light & Matter.	11	11	26
B. Detailed Study			
1. Sound.	13	13	26
			90

Students are permitted to bring into the examination room: pens, pencils, highlighters, erasers, sharpeners, rulers, up to two pages (one A4 sheet) of pre-written notes (typed or handwritten) and a scientific calculator. Students are not permitted to bring into the examination room: blank sheets of paper and/or white out liquid/tape.

Materials Supplied

Question and answers booklet with detachable data sheet.

Instructions

Detach the data sheet during reading time.

Write your name in the space provided.

Answer all questions in the question and answers booklet when indicated.

Also show your workings where space is provided.

Where an answer box has a unit printed in it, give your answer in that unit.

All responses must be in English.

Students are not permitted to bring mobile phones and/or any other unauthorised electronic devices into the examination room.

Learning Materials by Lisachem

PO Box 2018, Hampton East, Victoria, 3188

Ph: (03) 9598 4564 Fax: (03) 8677 1725

Email: orders@learningmaterials.com.au or orders@lisachem.com.au

Website: www.learningmaterials.com.au

Data Sheet VCE Physics 2009 Year 12 Trial Exam Unit 4

1	photoelectric effect	$E_{k \max} = hf - W$
2	photon energy	$E = hf$
3	photon momentum	$p = \frac{h}{\lambda}$
4	de Broglie wavelength	$\lambda = \frac{h}{p}$
5	resistors in series	$R_T = R_1 + R_2$
6	resistors in parallel	$\frac{1}{R_T} = \frac{1}{R_1} + \frac{1}{R_2}$
7	magnetic force	$F = nIlB$
8	electromagnetic induction	emf : $\mathcal{E} = -N \frac{\Delta\Phi}{\Delta t}$ flux : $\Phi = BA$
9	transformer action	$\frac{V_1}{V_2} = \frac{N_1}{N_2}$
10	AC voltage and current	$V_{\text{RMS}} = \frac{1}{\sqrt{2}} V_{\text{PEAK}}$ $I_{\text{RMS}} = \frac{1}{\sqrt{2}} I_{\text{PEAK}}$
11	voltage; power	$V = RI$ $P = VI$
12	transmission losses	$V_{\text{drop}} = I_{\text{line}} R_{\text{line}}$ $P_{\text{loss}} = I_{\text{line}}^2 R_{\text{line}}$
13	mass of the electron	$m_e = 9.11 \times 10^{-31} \text{ kg}$
14	charge on the electron	$e = -1.6 \times 10^{-19} \text{ C}$
15	Planck's constant	$h = 6.63 \times 10^{-34} \text{ Js}$ $h = 4.14 \times 10^{-15} \text{ eVs}$
16	speed of light	$c = 3.0 \times 10^8 \text{ ms}^{-1}$
Detailed Study 3.3 – Sound		
17	speed, frequency and wavelength, period	$v = f\lambda$ $T = \frac{1}{f}$
18	intensity and levels	sound intensity level (in dB) = $10 \log_{10} \left\{ \frac{I}{I_0} \right\}$ where $I_0 = 1.0 \times 10^{-12} \text{ W m}^{-2}$

Prefixes/Units

$$p = \text{pico} = 10^{-12}$$

$$n = \text{nano} = 10^{-9}$$

$$\mu = \text{micro} = 10^{-6}$$

$$m = \text{milli} = 10^{-3}$$

$$k = \text{kilo} = 10^3$$

$$M = \text{mega} = 10^6$$

$$G = \text{giga} = 10^9$$

$$t = \text{tonne} = 10^3 \text{ kg}$$

Student Name.....

VCE Physics 2009 Year 12 Trial Exam Unit 4

Student Answer Sheet

Instructions: use a **PENCIL** for **ALL** entries. For each question, shade the box that indicates your answer.

All answers must be completed like **THIS** example.
Marks will **NOT** be deducted for incorrect answers.

A	B	C	D
---	---	---	---

NO MARK will be given if more than **ONE** answer is completed for any one question.
If you make a mistake, **ERASE** the incorrect answer – **DO NOT** cross it out.

SECTION B: Detailed Study 3.3 – Sound

One answer per line

1	A	B	C	D	2	A	B	C	D
3	A	B	C	D	4	A	B	C	D
5	A	B	C	D	6	A	B	C	D
7	A	B	C	D	8	A	B	C	D
9	A	B	C	D	10	A	B	C	D
11	A	B	C	D	12	A	B	C	D
13	A	B	C	D					

VCE Physics 2009 Year 12 Trial Exam Unit 4

Section A – Core

Instructions for Section A
*Answer **all** questions **for both** Areas of study in this section in the spaces provided.
Where an answer box has a unit printed in it, give your answer in that unit.
You should take the value of g to be 10 m s^{-2} .
Where answer boxes are provided, write your final answer in the box.*

Area of Study

Area of Study 1 – Electric Power	1
Area of Study 2 – Interactions of Light and Matter	11

Area of Study 1 – Electric Power

This information relates to Question 1.

A bar magnet is free to rotate whilst in a magnetic field and is initially positioned as shown in **Figure 1**.

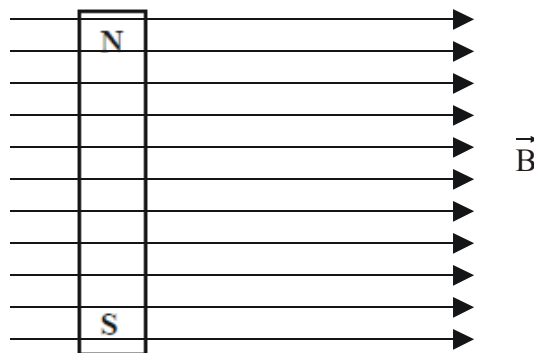
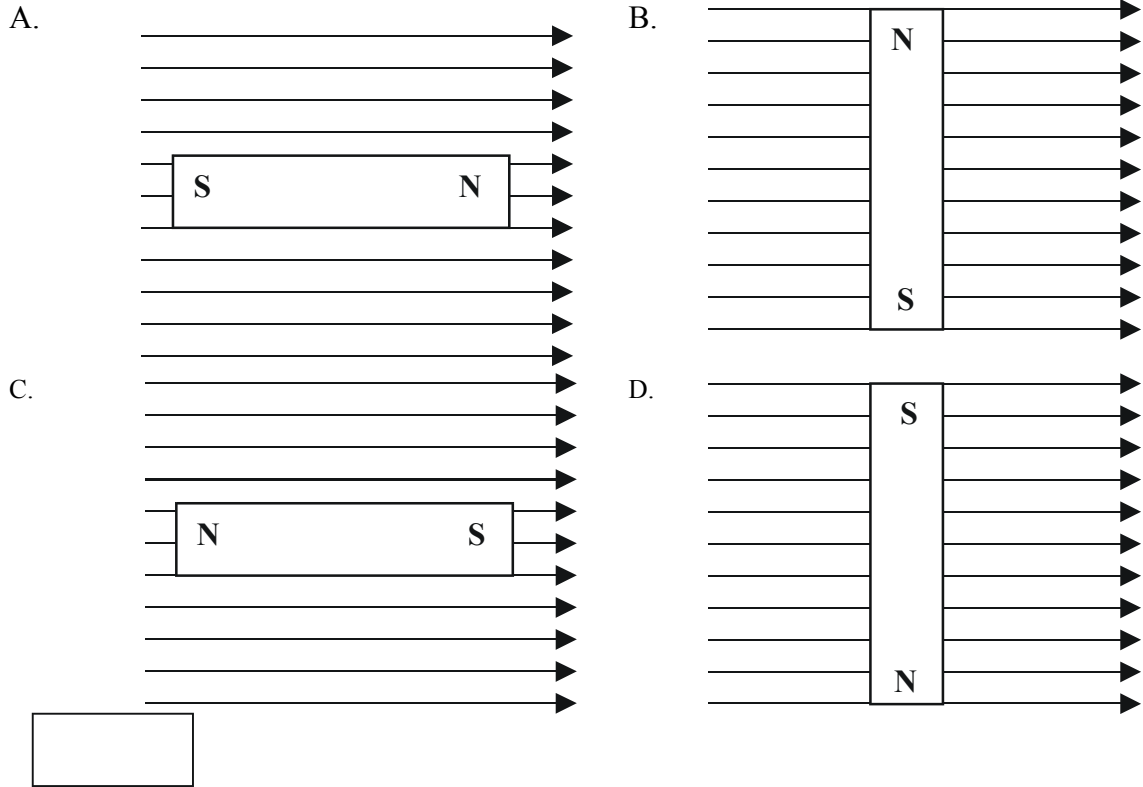

Figure 1

Question 1

Which one of the orientations, A – D, best indicates the final orientation of the bar magnet?



(2 marks)

Either single or double magnets are pushed into an aluminium ring with either a speed v or $2v$ as shown in **Figure 2**.

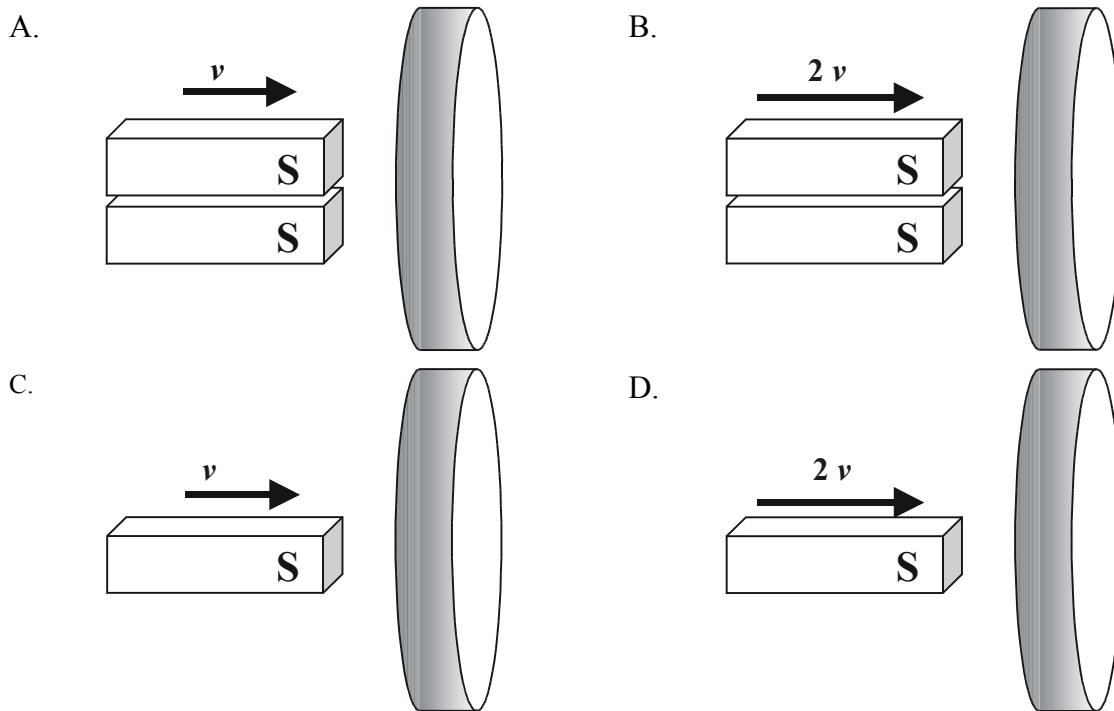

Figure 2

Question 2

In which one of the alternatives, A – D in **Figure 2**, is the magnitude of the induced current in the ring the greatest?

(2 marks)

Figure 3 and **Figure 4** show two views of a vertical wire carrying a current up through a horizontal card. Point P is marked on the card.

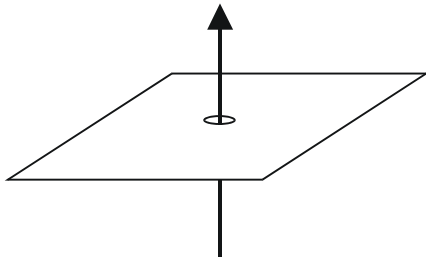

Figure 3

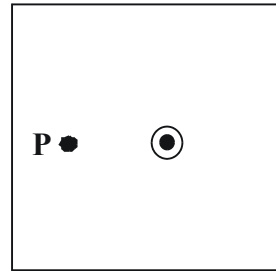

Figure 4 (top view)

Question 3

Through point P, on **Figure 4**, draw a complete magnetic field line and indicate its direction at point P.

(2 marks)

Questions 4 – 6 refer to the following information.

A simple generator consists of a coil of wire ABCD rotating steadily between the poles N and S of a permanent magnet. Four positions of the coil at different times are shown in **Figures 5, 6, 7** and **8**. In each case, an emf is induced in the coil and the resulting current flows from the coil through two rings that press against brushes, P and Q, to which a small lamp is connected. As seen from end X, the coil is rotating in a clockwise direction.

Question 4

In **Figure 6**, place an arrow on side AB to indicate the direction of the induced current in side AB at this instant.

If zero, write zero above the coil.

(2 marks)

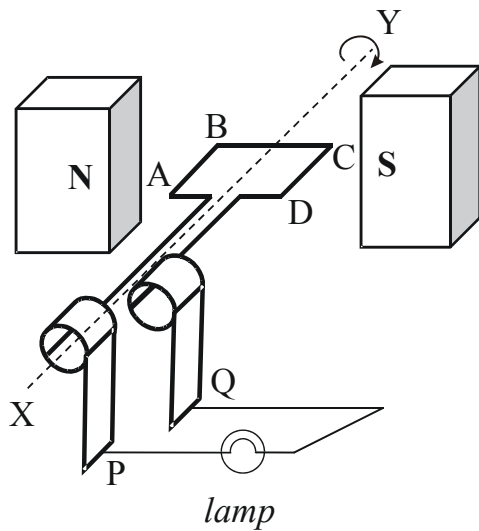

Figure 5

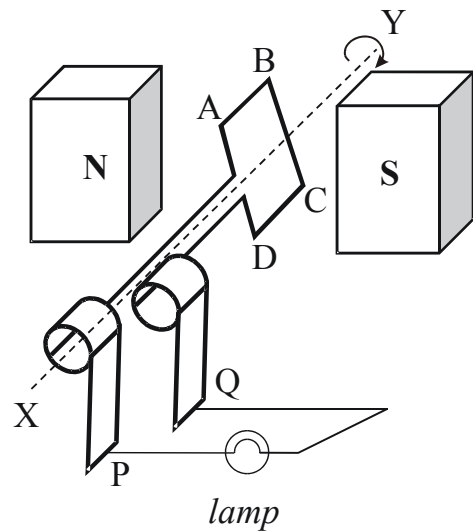

Figure 6

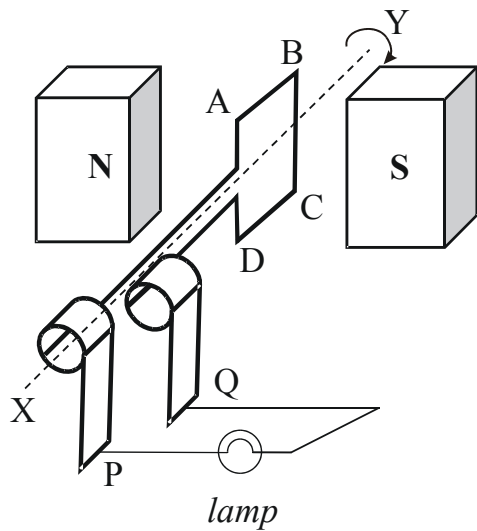

Figure 7

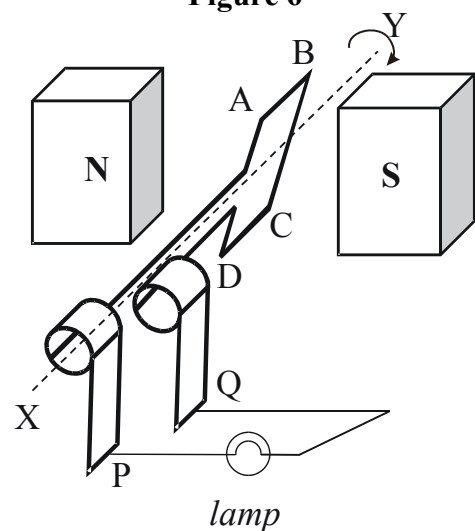

Figure 8

Question 5

In which one of the **Figures, 5-8**, is the magnetic flux threading the coil a *maximum*?

Figure

(1 mark)

Figures 9a, 9b and 9c show three positions of the same coil rotating in a clockwise direction in a uniform magnetic field, viewed end-on.

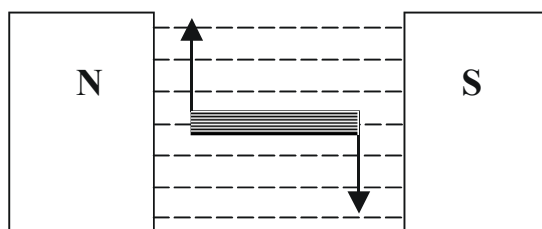

Figure 9a

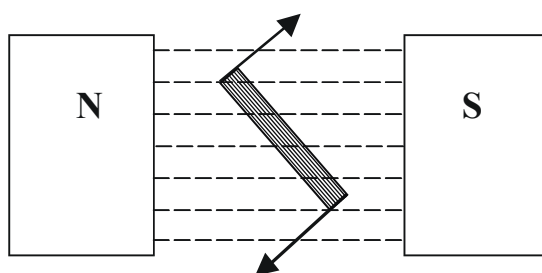

Figure 9b

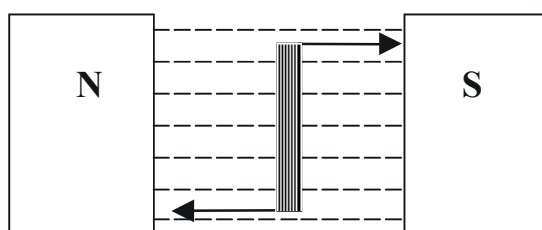

Figure 9c

The coil starts in the position shown in Figure 9a and rotates as shown. An emf is induced in the coil as shown in Figure 10.

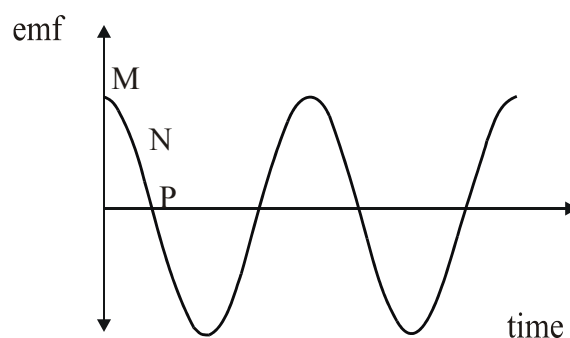

Figure 10

Question 6

Which position of the coil in **Figures 9a, 9b or 9c** corresponds to point M on the induced emf shown in **Figure 10**? Justify your answer.

(3 marks)

Questions 7 and 8 refer to the following information.

A rectangular coil consisting of 400 turns is positioned in a magnetic field of strength 0.15 T as shown in **Figure 11**. The magnetic field strength is then uniformly increased over a time period of 0.20 s which induces an average emf of 1.7 V in the coil.

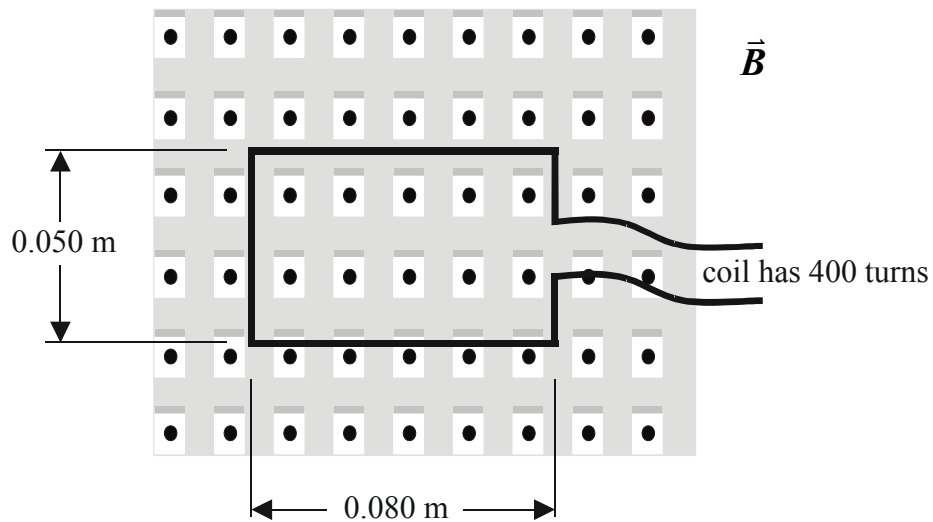

Figure 11

Question 7

Calculate the magnitude of the magnetic field strength at the end of the 0.20 s time interval.

(3 marks)

Question 8

Calculate the magnitude of the flux through the coil at the start of the 0.20 s time interval.

Wb

(2 marks)

Questions 9 and 10 refer to the following information.

A segment of a single strand wire loop, of length L m, is held fixed at right angles midway between the poles of a magnet as shown in **Figure 12**. A number of U shaped lengths of wire, each with the same total length but with the horizontal segment varying between 0.020 m and 0.10 m were placed, in turn, centred between the poles of the magnet. A current of 4.0 A was passed through each loop. **Figure 13** shows the relationship between the magnitude of the force on the wire and the length of the horizontal segment of the wire in the uniform magnetic field.

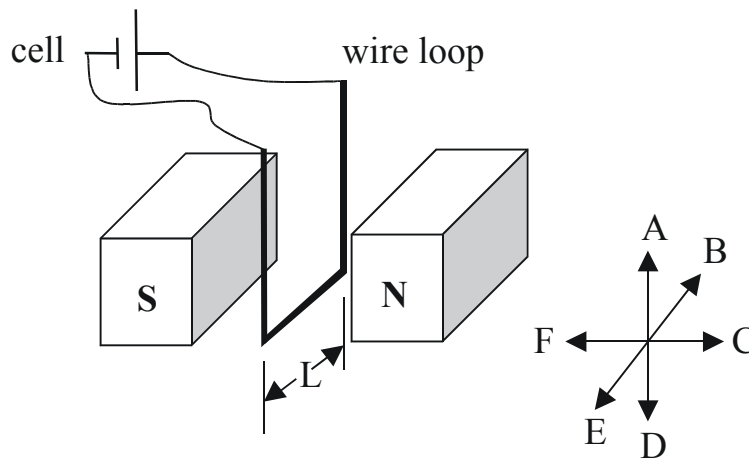

Figure 12

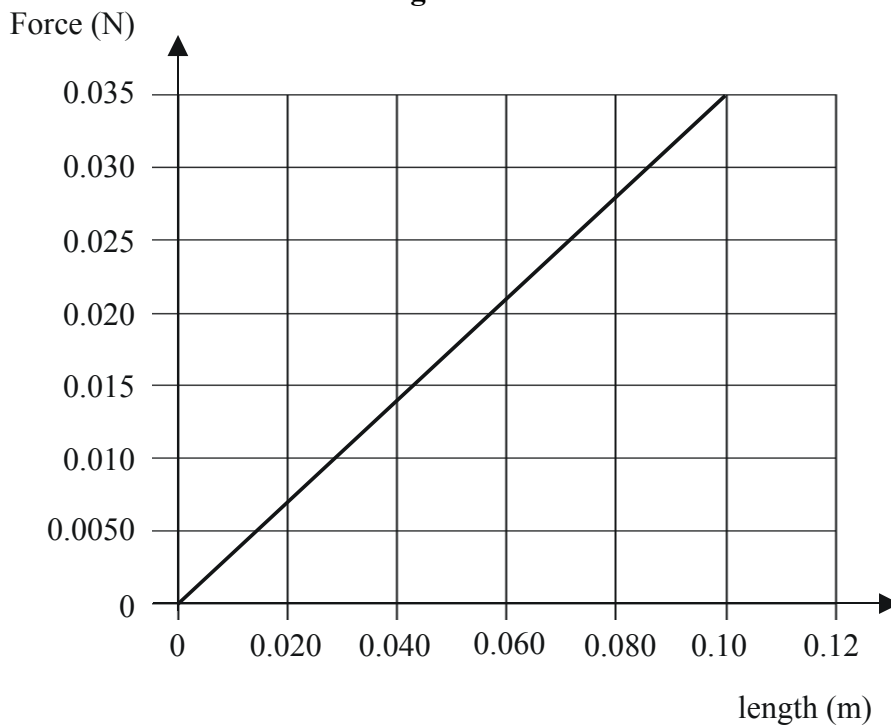

Figure 13

Question 9

Use the graph to calculate the magnitude of the strength of the magnetic field.

T

(2 marks)

Question 10

Which one of the alternative directions, A – F shown in **Figure 12**, gives the direction of the force acting on the wire segment of length L ?

--

(2 marks)

In a DC motor, there must be a continuous rotation of the coil in the magnetic field.

Question 11

Explain how this continuous rotation of the coil is achieved in a simple DC motor.

(4 marks)

Questions 12 and 13 refer to the following information.

An oscilloscope is connected to a sinusoidal AC source whose frequency and voltage output can be varied. At a certain frequency, the AC signal has an RMS output of 21.2 V. **Figure 14** shows the trace obtained on the screen of the oscilloscope when one horizontal division corresponds to a time of 20 ms.

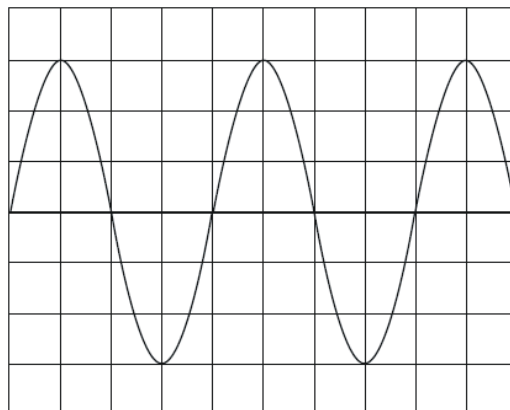

Figure 14

Question 12

For the signal shown, calculate the peak voltage.

(2 marks)

Question 13

For the signal shown, calculate the frequency.

(2 marks)

Questions 14 to 17 refer to the following information.

Electricity moves through a complex transmission system as shown in **Figure 15**.

Transformers are located near the electric generating plant and step up the electricity voltage from 25kV to 500 kV. From the transformers, electricity passes through heavy cables strung between tall towers that carry power over long distances to step-down transformers.

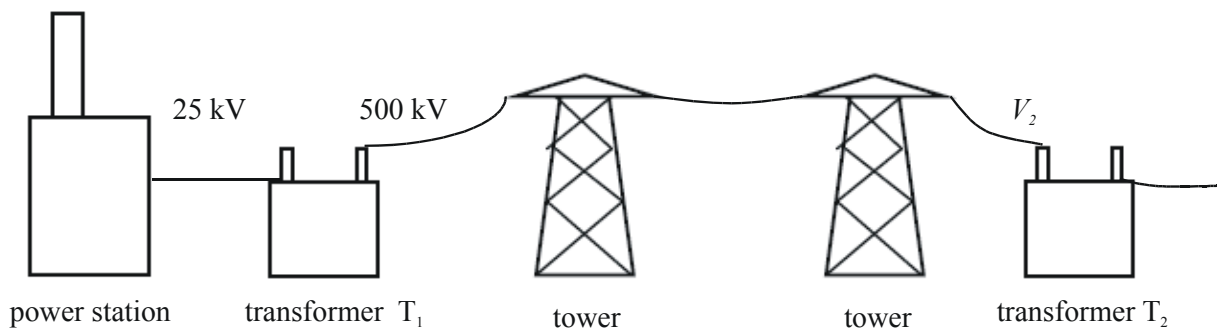

Figure 15

The power station in **Figure 15** generates 350 MW of electric power.

Question 14

Calculate the magnitude of the generated current.

(2 marks)

Question 15

Calculate the current in the secondary windings of transformer T_1 .

(2 marks)

Question 16

Calculate the value of the ratio;

$$\frac{\text{number of turns in the secondary windings}}{\text{number of turns in the primary windings}} \text{ of transformer } T_1.$$

(2 marks)

The total resistance of the transmission cables between the two transformers is 5.0Ω .

Question 17

Calculate the voltage, V_2 , of the primary coil of transformer T_2 .

(3 marks)

Area of Study 2 – Interactions of Light and Matter

Interference fringes are produced on a screen by illuminating a double slit with monochromatic light.

Question 1

Describe the effect on the separation of the fringes of increasing the distance from the screen to the slits.

(2 marks)

Questions 2 and 3 refer to the following information.

Figure 1 shows a 'Young double slit' arrangement for an experiment with light. P and Q are the slits and the path lengths PX and QX are $(n - \frac{1}{2})\lambda$ and $n\lambda$ respectively, where n is an integer. Monochromatic light of wavelength λ is incident on the two slits.

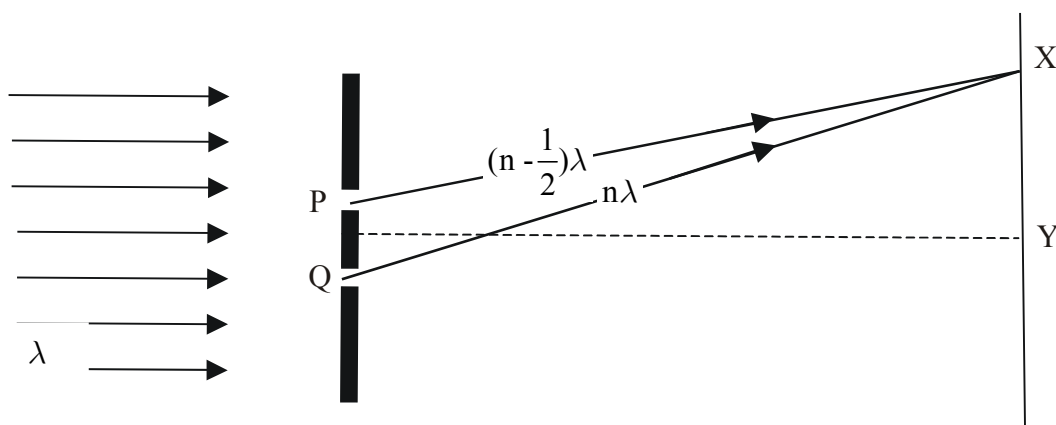

Figure 1

Question 2

State whether or not the fringe produced at X is bright. Justify your answer.

(3 marks)

Question 3

Explain why the central fringe at Y is bright.

(2 marks)

Questions 4 – 5 relate to the following information.

When light falls on particular metals, electrons are ejected from the metal. Investigation of this photoelectric effect can be carried out using a photocell as shown in **Figure 2**.

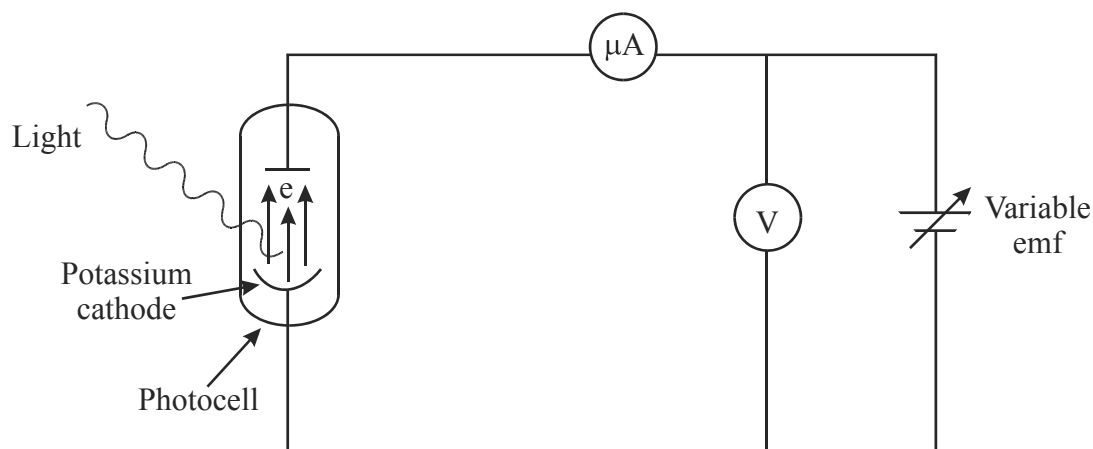

Figure 2

In one experiment, bright blue light is shone onto a potassium metal cathode and photoelectrons are emitted from the metal producing a small current. This is measured by the microammeter as the potential difference is uniformly increased. **Figure 3** shows the current - potential difference relationship for the experiment with bright blue light.

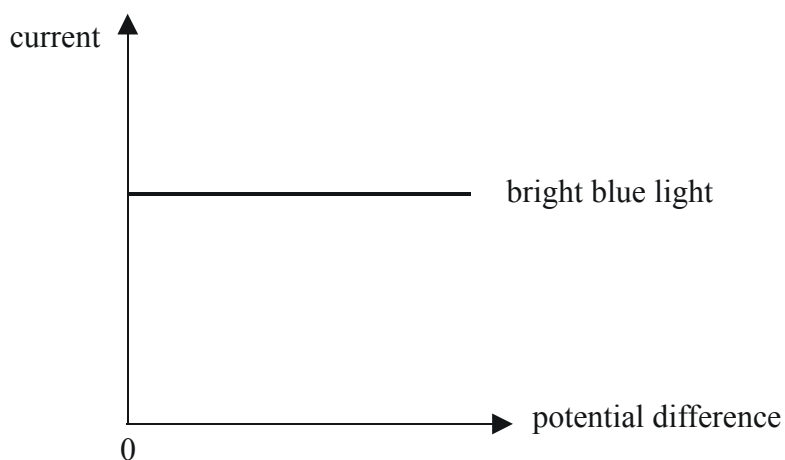

Figure 3

The intensity of the blue light is now *decreased* and the potential difference across the cell is slowly increased from zero.

Question 4

On **Figure 3**, draw the resulting current - potential difference relationship when *dim* blue light is shone onto the metal.

(2 marks)

Bright blue light is again shone onto the potassium electrode, but the terminals of the variable emf source in **Figure 2** are now reversed. The reversed voltage is now slowly increased until the photocell current decreases to zero at a potential difference of V_0 , as shown in **Figure 4**.

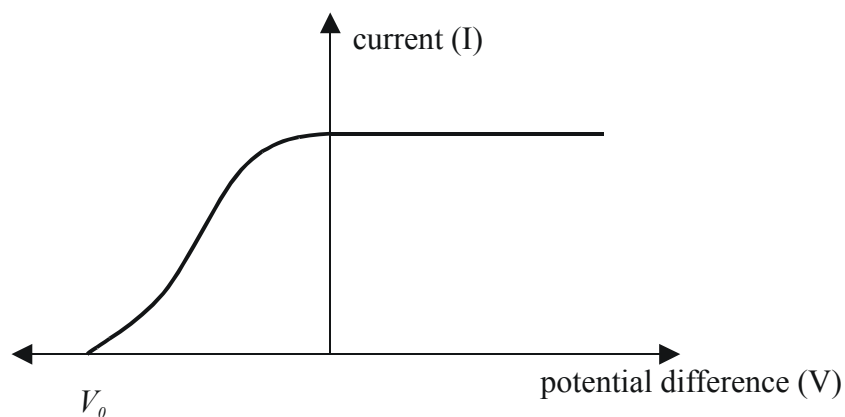

Figure 4

In one experiment, V_0 was measured to be 1.9 V.

Question 5

Calculate the maximum kinetic energy, in eV, of the photoelectrons emitted.

eV

(2 marks)

The relationship between the maximum kinetic energy of photoelectrons and the frequency of the incident radiation is shown in **Figure 5**.

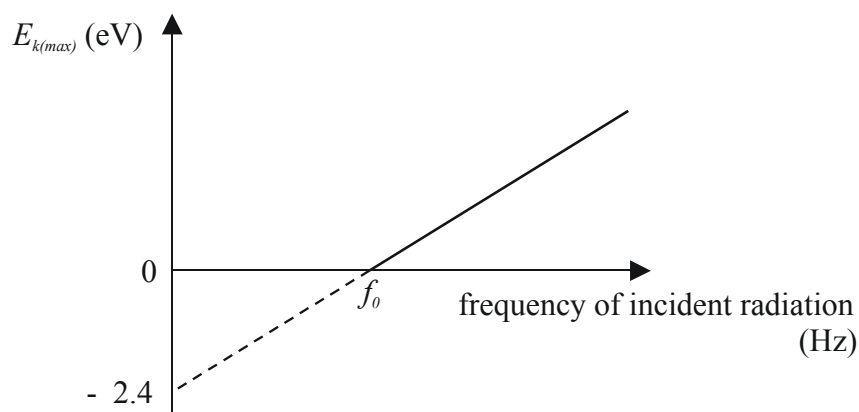

Figure 5

Question 6

With reference to **Figure 5**, calculate the magnitude of f_0 .

(2 marks)

Questions 7 – 10 refer to the following information.

The tungsten cathode in an electron microscope has a work function of 4.5 eV and is heated to release electrons that are initially at rest (near the cathode). The electrons are accelerated by a potential difference that creates a beam with a de Broglie wavelength of 0.040 nm. (Ignore non-relativistic effects).

Question 7

Calculate the magnitude of the momentum, in kg m s^{-1} , of an electron in the beam.

(2 marks)

Question 8

Calculate the kinetic energy, in J, of an electron in the beam.

(3 marks)

Suppose that, instead of heat, light is used to liberate electrons from the tungsten cathode.

Question 9

Calculate the minimum wavelength, in nm, of the radiation needed to accomplish this.

(3 marks)

Figure 6 shows part of the energy-level diagram for the hydrogen atom.

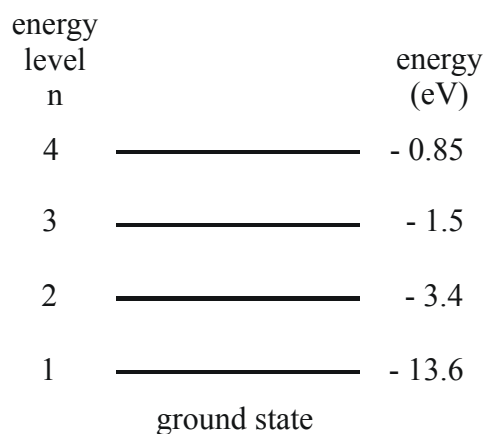

Figure 6

Question 10

Calculate the wavelength, in nm, of the photon emitted when an electron makes a transition from $n = 4$ to the ground state.

nm

(3 marks)

Figure 7 represents the wave amplitude of an electron ‘matter wave’ travelling in a circular orbit.

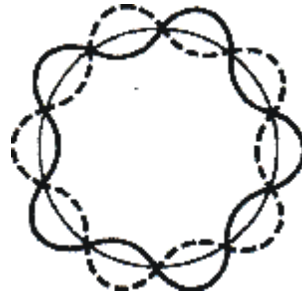

Figure 7

Question 11

In which quantum energy level, n , is this electron to be found?

$n =$

(2 marks)

End of Section A

VCE Physics 2009 Year 12 Trial Exam Unit 4

Section B – Detailed Study

Instructions for Section B

Answer **all** questions from the Detailed Study, in pencil, on the answer sheet provided for multiple choice questions.

Choose the response that is **correct** for the question.

A correct answer scores 2, an incorrect answer scores 0.

Marks will **not** be deducted for incorrect answers.

No marks will be given if more than one answer is completed for any question.

Detailed Study 3.3 – Sound

A microphone near a musical instrument, connected to a CRO, shows the air pressure variation with time (**Figure 1**) when the speed of sound is 340 m s^{-1} .

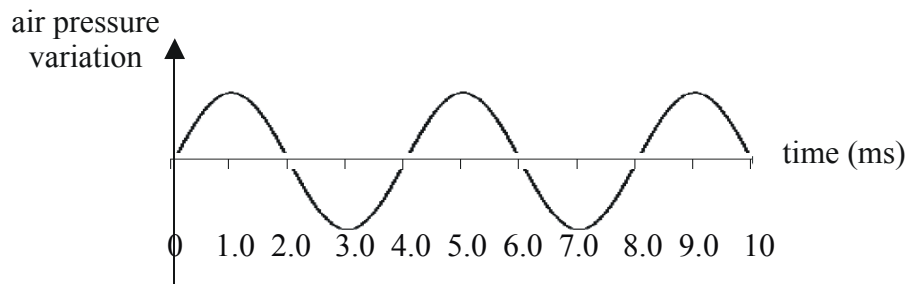

Figure 1

Question 1

Which one of the following gives the frequency, in Hz, of the sound produced by the musical instrument?

- A. 10
- B. 4.0
- C. 250
- D. 85

Question 2

Which one of the following conditions is *not* necessary for the formation of a stationary wave on a string?

- A. Two waves of equal amplitude.
- B. Two waves of equal frequency.
- C. Two waves travelling in the same direction.
- D. Two waves travelling in opposite directions.

A particular microphone has a small movable induction coil positioned in the magnetic field of a permanent magnet and is attached to the diaphragm. When sound enters through the microphone, sound wave vibrations move the diaphragm, which vibrates the coil. The coil moves in the magnetic field, producing a varying current through electromagnetic induction.

Question 3

Which one of the following microphones fits this description?

- A. Dynamic.
- B. Crystal.
- C. Condenser.
- D. Electret.

On **Figure 2**, a 1000 Hz sound at 80 dB is taken as the loudness standard.

Question 4

Which one of the following frequency-intensity level pairs would *not* sound equally as loud as the standard?

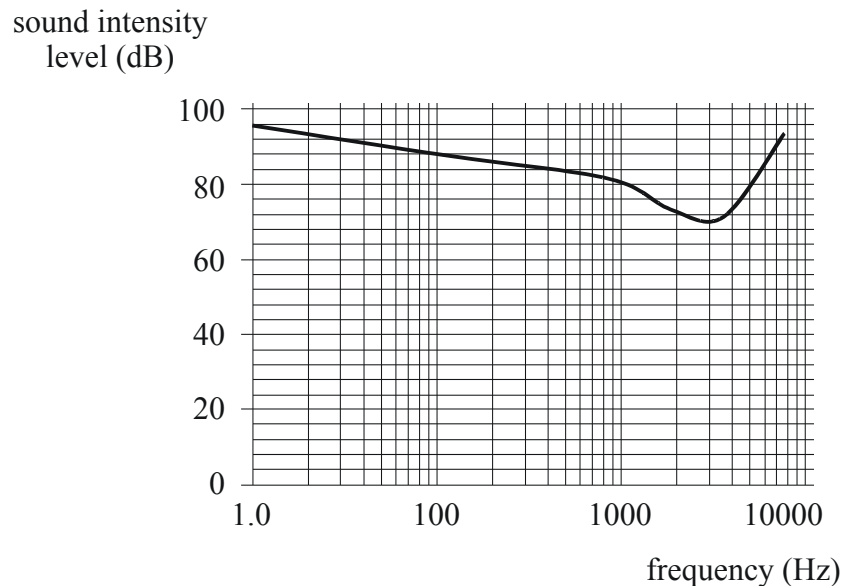

Figure 2

- A. 90 Hz, 88 dB.
- B. 3000 Hz, 70 dB.
- C. 100 Hz, 82 dB.
- D. 400 Hz, 84 dB.

Sound reproduction equipment shows variability in response and limitations to the input of different frequencies. **Figure 3** shows the frequency response of a particular loudspeaker.

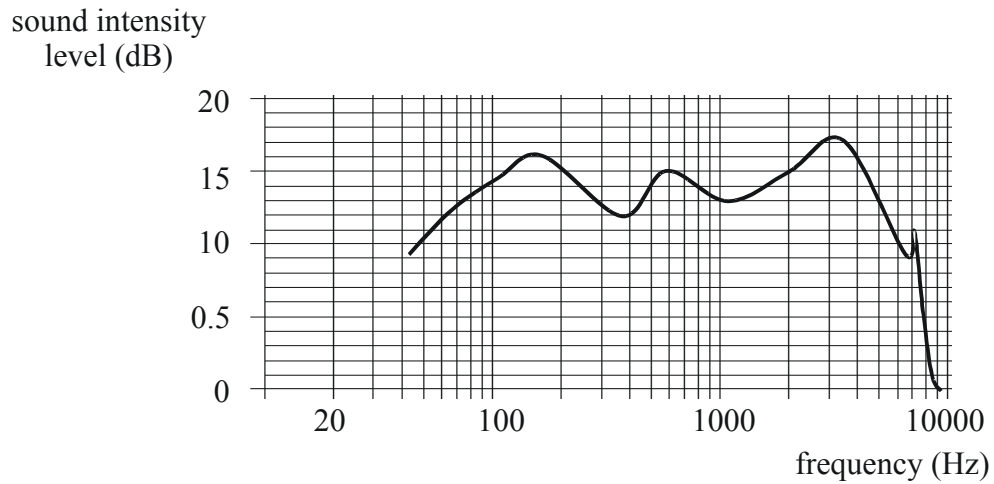

Figure 3

Question 5

Which set of responses best applies to this speaker?

	range of frequency response	flat range
A.	9 – 17	150 – 2000
B.	9 – 17	45 – 9000
C.	100 – 3500	45 – 9000
D.	45 – 9000	100 – 3500

Question 6

Which one or more of the following will cause diffraction of sound waves to increase on passing through a gap in a barrier?

- A. The width of the gap decreases.
- B. The width of the gap increases.
- C. The wavelength of the sound increases.
- D. The wavelength of the sound decreases.

Stephen sets up a loudspeaker (L) on a stand at the centre of the school oval on a still day (**Figure 4**).

The loudspeaker emits sound uniformly in all directions. Reflection from the ground can be ignored.

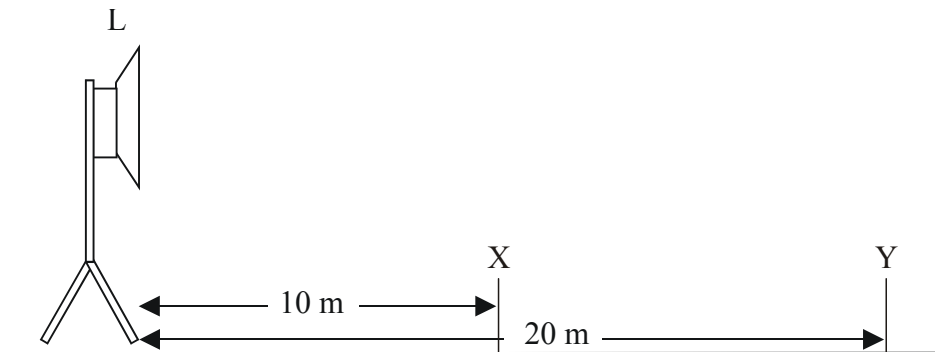

Figure 4

At the point X, which is 10 m from the loudspeaker, a student, Cathy, measures the sound intensity level to be 80 dB.

Question 7

Which one of the sound intensities listed below (**A–D**) is the sound intensity, in W m^{-2} , at point X?

- A. 10^{-4}
- B. 1.9×10^{-12}
- C. 8.0×10^{-12}
- D. 9.0×10^{-12}

Cathy now moves to point Y, which is 20 m away from the loudspeaker.

Question 8

Which one of the sound intensities listed below is the sound intensity, in W m^{-2} , at point Y?

- A. 10^{-8}
- B. 5.0×10^{-5}
- C. 2.5×10^{-5}
- D. 10^{-2}

When the cone of a speaker vibrates to produce sound, sound reflected from the back of the speaker is out of phase with sound from the front of the speaker and interference occurs.

Question 9

Which one of the following ways is the best remedy for this problem?

- A. Use a baffle board to prevent interaction.
- B. Make the vibrating cone of the speaker smaller.
- C. Use a smaller speaker cabinet to decrease resonance.
- D. Use softer construction material to absorb the sound.

Figure 5 shows a depiction of air pressure and density variations for a standing wave in an open cylinder. The ends are constrained to be nodes of pressure, N.



Figure 5

- A.
- B.
- C.
- D.

Question 10

Which one of the graphs, A – D, corresponds to the pressure variation at the instant shown in **Figure 5**?



Figure 5 represents the distribution of air particles in a flute at a particular instant when the pressure variations from normal are at a maximum.

Question 11

Which harmonic and overtone is being played?

- A. The fundamental; no overtone.
- B. Second harmonic; first overtone.
- C. Third harmonic; second overtone.
- D. Fourth harmonic; third overtone.

A flute can be modelled as a pipe open at both ends with an effective length of 0.65 m.

Question 12

Which one of the following best gives the frequency of the lowest note that can be played by the flute?

- A. 65 Hz.
- B. 130 Hz.
- C. 260 Hz.
- D. 520 Hz.

A microphone's frequency response pattern is shown in **Figure 6** and is referred to as a frequency response curve.

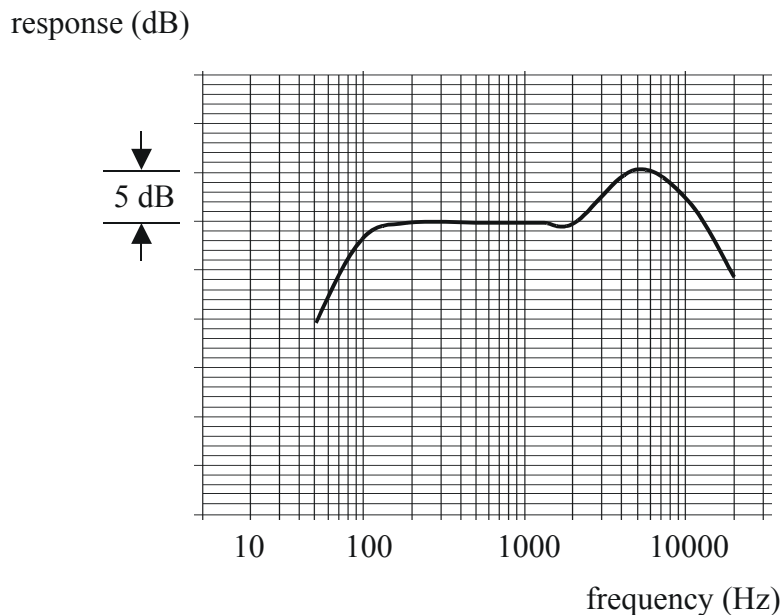

Figure 6

Question 13

Which one of the following uses would the microphone with this frequency response be best suited for?

- A. A vocal microphone.
- B. A microphone for a bass drum.
- C. A microphone for a violin.
- D. A microphone for a soprano who reaches high notes when singing.

End of Section B

End of Trial Exam

Suggested Answers

VCE Physics 2009 Year 12 Trial Exam Unit 4

Section A – Core

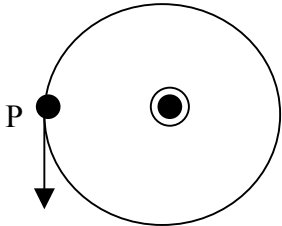
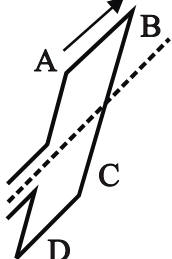
Area of Study 1 – Electric Power	Marks Allocation
Question 1 Answer: A	2
Question 2 Answer: B (The pair of magnets with a speed of $2v$)	2
Question 3 The field lines are circular around the current-carrying wire. The direction of the force is tangential and anticlockwise. <div style="text-align: center;">  </div>	1 1
Question 4 The face of the coil moving toward the south pole of the magnet will have a south pole induced which opposes motion. The current will flow from A to B. <div style="text-align: center;">  </div>	2
Question 5 Answer: Figure 7. The coil is perpendicular to the magnetic field	1
Question 6 Answer: Figure 9a. With the coil in position (a), the two sides of the coil, A and B, are moving at right angles to the field lines and consequently cutting them at a maximum rate. The induced emf will have a maximum value of M , falling to zero when the coil is perpendicular to the field lines.	1 1 1

<p>Question 7 Use the formula;</p> $\varepsilon = -\frac{N\Delta\phi}{\Delta t}$ $1.7 = \frac{400 \times (0.050 \times 0.080) \times \Delta B}{0.20}$ $\Delta B = 0.213 \text{ T}$ $\Delta B = B_f - B_i$ $B_f = 0.213 + 0.15$ $= 0.36 \text{ T}$	<p>1</p> <p>1</p> <p>1</p>
<p>Question 8 Use;</p> $\Phi = BA$ $= 0.15 \times 0.050 \times 0.080$ $= 6.0 \times 10^{-4} \text{ Wb}$	<p>1</p> <p>1</p>
<p>Question 9 Use;</p> $F = nIlB$ <p>For F plotted against l, the gradient is numerically equal to the product IB.</p> $IB = \frac{0.035}{0.10}$ $B = \frac{0.035}{0.10 \times 4.0}$ $B = 0.088$ $B = 8.8 \times 10^{-2} \text{ T}$	<p>1</p> <p>1</p>
<p>Question 10 Use the right hand rule; Answer D.</p>	<p>2</p>
<p>Question 11 To achieve continuous rotation of the coil in a DC motor, DC current is supplied to the coil by way of a pair of brushes and a split-ring commutator. As plane of the coil passes through the vertical position, the attached split-ring commutator reverses the direction of the current into the coil causing the coil to rotate another 180° in the same direction, after which the current will again reverse.</p>	<p>1 + 1</p> <p>1</p> <p>1</p>
<p>Question 12 Use;</p> $V_{PEAK} = V_{RMS} \times \sqrt{2}$ $= 21.2 \times \sqrt{2}$ $= 30 \text{ V}$	<p>1</p> <p>1</p>

<p>Question 13</p> <p>Use;</p> $f = \frac{1}{T}$ $= \frac{1}{4 \times 20 \times 10^{-3}}$ $= 12.5$ $= 13 \text{ Hz}$	<p>1</p> <p>1</p>
<p>Question 14</p> <p>Use;</p> $P = VI$ $I = \frac{P}{V}$ $= \frac{350 \times 10^6}{25 \times 10^3}$ $= 1.4 \times 10^4 \text{ A}$	<p>1</p> <p>1</p>
<p>Question 15</p> <p>Use;</p> <p>power in = power out</p> $350 \times 10^6 = 500 \times 10^3 \times I$ $I = \frac{350 \times 10^6}{500 \times 10^3}$ $= 700 \text{ A}$	<p>1</p> <p>1</p>
<p>Question 16</p> <p>Use;</p> $\frac{N_1}{N_2} = \frac{V_1}{V_2}$ $\frac{N_2}{N_1} = \frac{500 \times 10^3}{25 \times 10^3}$ $= 20$	<p>1</p> <p>1</p>

<p>Question 17</p> <p>There is a power loss due to heating of the transmission cable.</p> <p>Power loss;</p> $= I^2 R$ $= 700^2 \times 5.0$ $= 2.45 \text{ MW}$ <p>power available at T_2</p> $= (350 - 2.45) \text{ MW}$ <p>use;</p> $V = \frac{P}{I}$ $= \frac{(350 - 2.45) \times 10^6}{700}$ $= 496500$ $= 497 \text{ kV}$	<p>1</p> <p>1</p> <p>1</p>
--	----------------------------

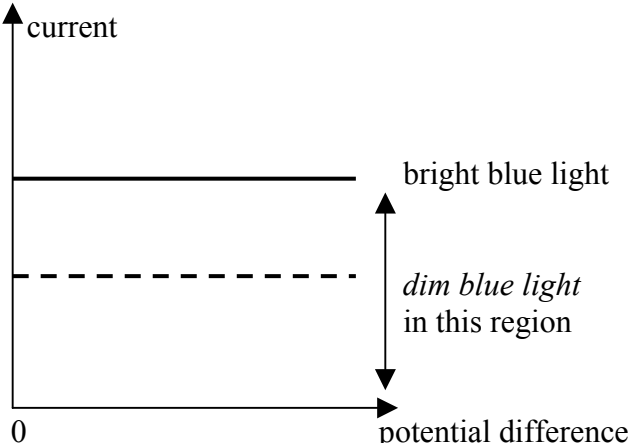
Area of Study 2 – Interactions of Light and Matter	Marks Allocation
<p>Question 1</p> <p>The fringe spacing is directly proportional to the distance of the screen from the slits. So the fringe spacing will increase as distance from the screen increases.</p>	<p>1</p> <p>1</p>
<p>Question 2</p> <p>The fringe produced at X is a dark fringe. Because the path difference $n\lambda - (n - \frac{1}{2})\lambda$ is a half wavelength, there will be destructive interference at X.</p>	<p>1</p> <p>1</p> <p>1</p>
<p>Question 3</p> <p>A bright fringe is found at Y because the path difference from the slits is zero and there is constructive interference at Y.</p>	<p>1</p> <p>1</p>
<p>Question 4</p> <p>Ans: a horizontal line between the potential difference axis and the graph for bright blue light.</p> 	<p>2</p>

<p>Question 5 Use; $E_{k\max} = eV_0$ $= 1.9 \text{ eV}$</p>	<p>1 1</p>
<p>Question 6 The gradient of the graph is numerically equal to Planck's constant; Use; $h = \frac{\Delta W}{f_0}$ $f_0 = \frac{2.4}{4.14 \times 10^{-15}}$ $= 5.8 \times 10^{14} \text{ Hz}$</p>	<p>1 1</p>
<p>Question 7 Use; $\lambda = \frac{h}{p}$ $p = \frac{h}{\lambda}$ $= \frac{6.63 \times 10^{-34}}{0.040 \times 10^{-9}}$ $= 1.66 \times 10^{-23}$ $= 1.7 \times 10^{-23} \text{ kg m s}^{-1}$</p>	<p>1 1</p>
<p>Question 8 First, calculate the speed of the electron; $v = \frac{p}{m}$ $= \frac{1.66 \times 10^{-23}}{9.1 \times 10^{-31}}$ $= 1.82 \times 10^7 \text{ ms}^{-1}$ now, $E_k = \frac{1}{2}mv^2$ $= \frac{1}{2} \times 9.1 \times 10^{-31} \times (1.82 \times 10^7)^2$ $= 1.51 \times 10^{-16} \text{ J}$</p>	<p>1 1 1</p>

<p>Question 9 From the photoelectric equation; $E_{k\max} = hf - W$ when $E_{k\max} = 0$ $W = hf$ $= \frac{hc}{\lambda}$ $\lambda = \frac{4.14 \times 10^{-15} \times 3.0 \times 10^8}{4.5}$ $\lambda = 2.76 \times 10^{-7} \text{ m}$ $\lambda = 280 \text{ nm}$</p>	1 1 1
<p>Question 10 Use; $E_2 - E_1 = \frac{hc}{\lambda}$ $-0.85 - (-13.6) = \frac{4.14 \times 10^{-15} \times 3.0 \times 10^8}{\lambda}$ $\lambda = 9.74 \times 10^{-8} \text{ m}$ $= 97 \text{ nm}$</p>	1 1 1
<p>Question 11 The number of wavelengths is 5, which is numerically the same as the principal quantum number, n. Answer: n = 5</p>	2

Detailed Study 3.3 – Sound	Marks Allocation
<p>Question 1 Use; $T = \frac{1}{f}$ $= \frac{1}{4.0 \times 10^{-3}}$ $= 250 \text{ Hz}$</p> <p>Answer: C</p>	2
<p>Question 2 Answer: C Two waves travelling in the same direction.</p>	2
<p>Question 3 Answer: A A dynamic microphone.</p>	2
<p>Question 4 All points along the frequency-intensity level curve have the same loudness. Answer: C The ordered pair (100,82) does not lie on the curve.</p>	2

<p>Question 5 The set {45 – 9000 ; 100 – 3500 } is the best description of the speaker. Answer: D</p>	2
<p>Question 6 Diffraction of sound waves passing through a gap in a barrier will increase if; the width of the gap decreases and the wavelength of the sound increases. Answer: A,C</p>	2
<p>Question 7 Use; $\beta = 10 \log \frac{I_1}{I_0}$ $80 = 10 \log \frac{I_1}{10^{-12}}$ $10^8 = \frac{I_1}{10^{-12}}$ $I_1 = 10^{-4} \text{ W m}^{-2}$ Answer: A</p>	2
<p>Question 8 Since the distance has doubled, the intensity at Y will be one quarter of the value at X. Use; $I_1 d_1^2 = I_2 d_2^2$ $I_2 = \frac{10^{-4} \times 10^2}{20^2}$ $= 2.5 \times 10^{-5} \text{ W m}^{-2}$ Answer: C</p>	2
<p>Question 9 Answer: A Baffle boards prevent interaction, with consequent destruction because they are out of phase, of sound reflected from the back of the speaker and sound emitted from the front of the speaker.</p>	2
<p>Question 10 Answer: C There are two regions of high pressure and two regions of low pressure with the first region, on the left, being a low pressure region.</p>	2
<p>Question 11 There are 4 antinodes and 5 nodes which correspond to the fourth harmonic and third overtone. Answer: D</p>	2

<p>Question 12 The wavelength of the fundamental frequency is twice the length of the flute. Use; $L = 0.65 \text{ m}$ so, $\lambda = 1.3 \text{ m}$ $v = f\lambda$ $f = \frac{v}{\lambda}$ $= \frac{340}{1.3}$ $= 261.5$ $= 2.6 \times 10^2 \text{ Hz}$ Answer: C</p>	2
<p>Question 13 The frequency response curve indicates a boost in frequencies in the vocal range. Low frequencies (bass drum) and high frequencies (violin and soprano) are attenuated. Answer: A</p>	2

End of Suggested Answers