



## VCE PHYSICS 2008

### YEAR 12 TRIAL EXAM UNIT 4

#### CONDITION OF SALE:

© Limited copyright. This paper may be photocopied without charge for use only within the school that has purchased the material. Our electronic copy only may be placed on the school intranet for the exclusive use by the teachers and students of the school that has purchased the material. They may **not** otherwise be reproduced (all or part) electronically, scanned into a school computer, forwarded via email, or placed on the Internet, without written consent of the publisher.

**Reading Time: 15 minutes**

**Writing Time: 1h 30m**

#### Structure of Booklet

Section	No of questions	No of questions to be answered	No of marks
<b>A. Core Area of Study</b>			
1. Electric Power	18	18	40
2. Interactions of Light & Matter	11	11	25
<b>B. Detailed Study</b>			
3. Sound	13	13	25
			<b>Total 90</b>

Students are permitted to bring into the examination room: pens, pencils, highlighters, erasers, sharpeners, rulers, up to two pages (one A4 sheet) of pre-written notes (typed or handwritten) and a scientific calculator. Students are not permitted to bring into the examination room: blank sheets of paper and/or white out liquid/tape.

#### Materials Supplied

Question and answers booklet with detachable formula sheet.

#### Instructions

Detach the formula sheet during reading time.

Write your name in the space provided.

Answers all questions in the question and answers booklet when indicated.

Also show your workings where space is provided.

Where an answer box has a unit printed in it, give your answer in that unit.

All responses must be in English.

**Students are not permitted to bring mobile phones and/or any other unauthorised electronic devices into the examination room.**

#### Learning Materials by Lisachem

PO Box 2018, Hampton East, Victoria, 3188

Ph: (03) 9598 4564 Fax: (03) 8677 1725

Email: [orders@learningmaterials.com.au](mailto:orders@learningmaterials.com.au) or [orders@lisachem.com.au](mailto:orders@lisachem.com.au)

Website: [www.learningmaterials.com.au](http://www.learningmaterials.com.au)

## Data Sheet VCE Physics 2008 Year 12 Trial Exam Unit 4

1	photoelectric effect	$E_{K \max} = hf - W$
2	photon energy	$E = hf$
3	photon momentum	$p = \frac{h}{\lambda}$
4	de Broglie wavelength	$\lambda = \frac{h}{p}$
5	resistors in series	$R_T = R_1 + R_2$
6	resistors in parallel	$\frac{1}{R_T} = \frac{1}{R_1} + \frac{1}{R_2}$
7	magnetic force	$F = IlB$
8	electromagnetic induction	<i>flux</i> : $\Phi = BA$ ; <i>emf</i> : $\mathcal{E} = -N \frac{\Delta\Phi}{\Delta t}$
9	transformer action	$\frac{V_1}{V_2} = \frac{N_1}{N_2}$
10	AC voltage and current	$V_{RMS} = \frac{1}{\sqrt{2}} V_{Peak}$ $I_{RMS} = \frac{1}{\sqrt{2}} I_{Peak}$
11	Voltage; power	$V = RI$ $P = VI$
12	transmission losses	$V_{Drop} = I_{Line} R_{Line}$ $P_{Loss} = I_{Line}^2 R_{Line}$
13	mass of the electron	$m_e = 9.1 \times 10^{-31} \text{ kg}$
14	charge on the electron	$q = -1.6 \times 10^{-19} \text{ C}$
15	Planck's constant	$h = 6.63 \times 10^{-34} \text{ J s}$ $= 4.14 \times 10^{-15} \text{ eV s}$
16	speed of light	$c = 3.0 \times 10^8 \text{ m s}^{-1}$
17	Acceleration due to gravity near the Earth's surface	$g = 10 \text{ m s}^{-2}$

### Detailed Study 3.3 – Sound

1	speed, frequency and wavelength	$v = f\lambda$ $T = \frac{1}{f}$
2	intensity and levels	sound intensity level $(\text{in dB}) = 10 \log_{10} \left\{ \frac{I}{I_0} \right\}$ where $I_0 = 1.0 \times 10^{-12} \text{ W m}^{-2}$

## Prefixes / Units

$$p = \text{pico} = 10^{-12}$$

$$n = \text{nano} = 10^{-9}$$

$$\mu = \text{micro} = 10^{-6}$$

$$m = \text{milli} = 10^{-3}$$

$$k = \text{kilo} = 10^3$$

$$M = \text{mega} = 10^6$$

$$G = \text{giga} = 10^9$$

$$1 \text{ tonne} = 10^3 \text{ kg}$$

# VCE Physics 2008 Year 12 Trial Exam Unit 4

## Section A – Core

### Instructions for Section A

Answer **all** questions for both Areas of study in this section of the paper

### Area of Study 1 – Electric power

Questions 1 and 2 relate to the following information.

Two wires, PQ and RS are parallel. Each wire is carrying a current in the direction indicated by the arrows shown in **Figure 1**.

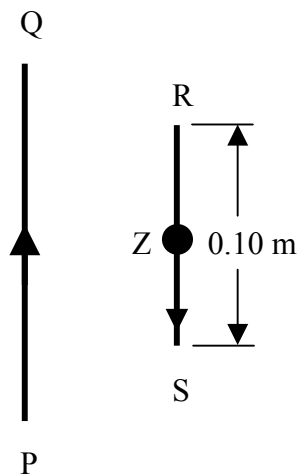

**Figure 1**

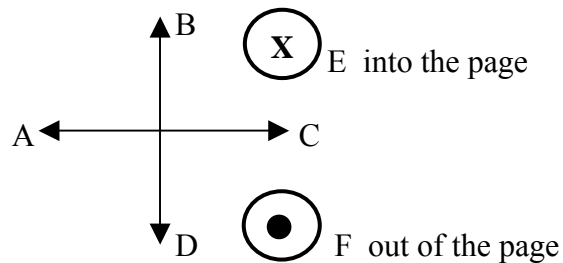

**Figure 2**

The point Z is in the middle of wire RS. **Figure 1** gives choices of directions A – F.

#### Question 1

Which one of the alternative directions, A – F, shown in **Figure 2**, gives the direction of the magnetic field at point Z due to the current flowing in wire PQ

**(2 marks)**

The magnetic field strength at point Z on RS due to the current in wire PQ is determined to be 0.020 T.

Wire RS carries a current of 2.5 A in the direction shown in **Figure 1**.

**Question 2**

Calculate the magnitude of the magnetic force acting on wire RS and use **Figure 2** to indicate the direction of the force.

Force =	N	Direction .....
---------	---	-----------------

**(3 marks)**

Questions 3 – 7 refer to the following information.

**Figure 3** shows a simple generator that can be used to investigate electromagnetic induction. The coil ABCD in the magnetic field is rotated at a constant speed in the direction shown. The ends of the coil are connected to slip rings which in turn are connected to a centre-zero milliammeter. **Figure 4** shows four positions that side AB of the coil can occupy as the coil ABCD rotates on its axis as viewed from point Z.

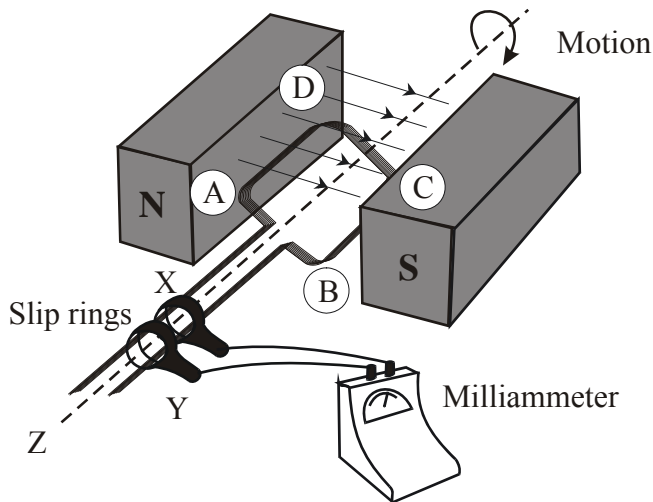

**Figure 3**

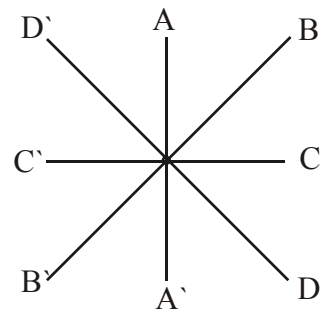

**Figure 4**

**Question 3**

In which position of the coil, AA' - DD', would the magnitude of the magnetic flux be a minimum?

**(2 marks)**

**Question 4**

Which one of the following graphs of current versus time shows how the current flowing through the milliammeter varied with time?

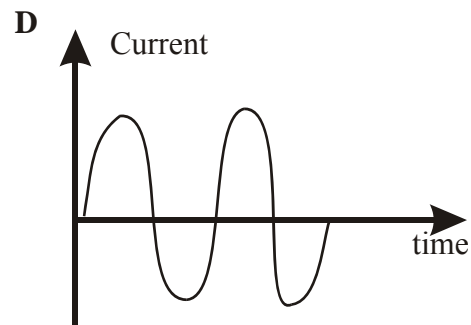
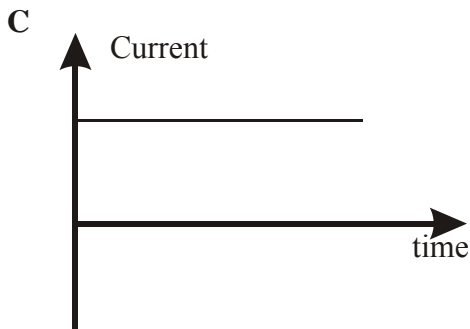
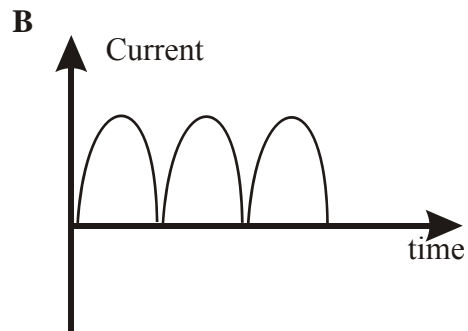
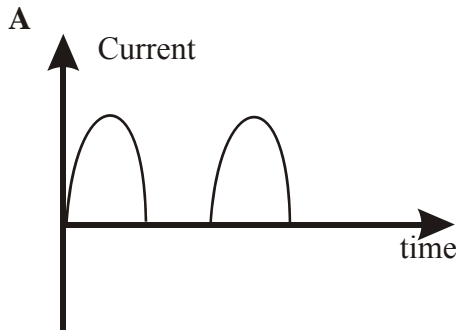

**(2 marks)**

The coil is now connected to a cathode ray oscilloscope (CRO) and is rotated at a constant speed. The trace obtained on the CRO is shown in **Figure 5**.

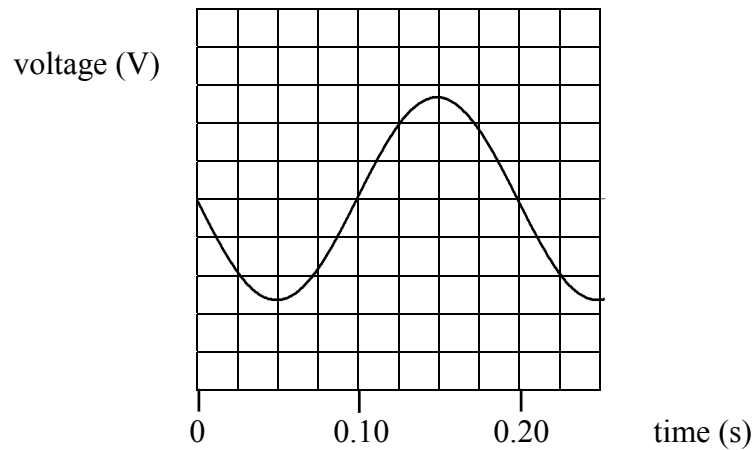

**Figure 5**

**Question 5**

Calculate the frequency of rotation of the coil.

Hz
----

(2 marks)

The uniform magnetic field strength between the poles of the magnet is 0.25 T, the coil consists of one turn and the area of the coil is 0.050 m<sup>2</sup>.

**Question 6**

The coil is initially aligned with the magnetic field lines. Calculate the magnitude of the average emf generated between the ends of the coil when it is rotated through 90° at the frequency calculated in **Question 5**.

V
---

(2 marks)

**Question 7**

Explain why the voltage generated by a coil turning in a magnetic field as shown in Figure 3 is not constant. Your answer should make reference to flux changes with time and positive and negative emf values.

---

---

---

---

---

---

---

(4 marks)

**Question 8**

Which one, or more of the following possible changes would **increase** the magnitude of the generated emf?

- A. increase the number of turns on the coil.
- B. increase the distance between the poles of the magnet.
- C. use thinner wire for the turns of the coil.
- D. increase the speed of rotation of the coil.
- E. all of the above.

--

(2 marks)

Questions 9 and 10 refer to the following information.

The generator in **Figure 6** is modified by removing the milliammeter and slip rings, then including a split-ring commutator, a battery that was connected to X and Y and a switch as shown in **Figure 6**.

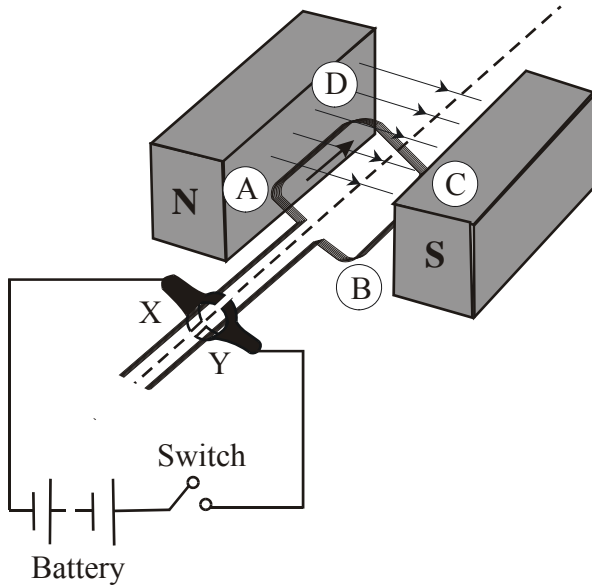

**Figure 6**

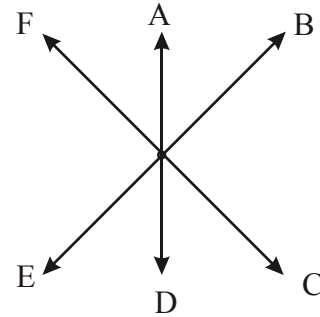

**Figure 7**

**Question 9**

Which one of the directions, A – F, as shown in **Figure 7**, gives the direction of the force on side **AD** when the switch closed?

**(2 marks)**

**Question 10**

Explain how the split-ring commutator enables the coil to rotate always in the same direction.

---



---



---



---



---

**(3 marks)**



Questions 11 – 15 refer to the following information.

The electrical energy supply to a house in a country area enters a pole transformer from a high voltage feeder line and is stepped down to a voltage of 240 V RMS as shown in **Figure 8**. The wires connecting the step-down transformer to the house have a total resistance of 0.150 ohm. The primary-secondary turns ratio of the transformer is 45:1.

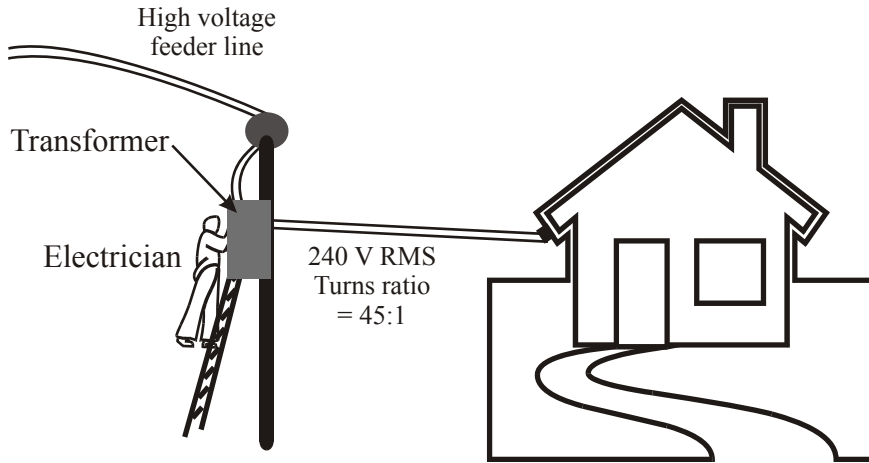

**Figure 8**

**Question 11**

Calculate the peak voltage across the output terminals of the transformer.

$V_{PEAK} =$		V
--------------	--	---

**(2 marks)**

There are 220 turns in the primary winding of the transformer.

**Question 12**

Calculate the RMS voltage, in kV, of the feeder line.

$V_{RMS} =$		kV
-------------	--	----

**(2 marks)**

An electrician conducted a load test on the system. At this particular time, 20 kW of electric power was being drawn from the output terminals of the transformer.

**Question 13**

Calculate the RMS current, in ampere, flowing in the transmission wires from the transformer to the house.

**(2 marks)**

**Question 14**

Calculate the power loss, in watt, in the transmission wires between the transformer and the house.

**(2 marks)**

**Question 15**

Calculate the RMS voltage available at the house.

**(2 marks)**

A transformer, which is a device to change the magnitude of an AC voltage, consists of a primary and a secondary coil which are wound around a soft iron laminated core.

**Question 16**

Explain how a transformer works discussing how different voltages are produced.

---

---

---

**(2 marks)**

Two identical bar magnets are oriented as shown in **Figure 9**.

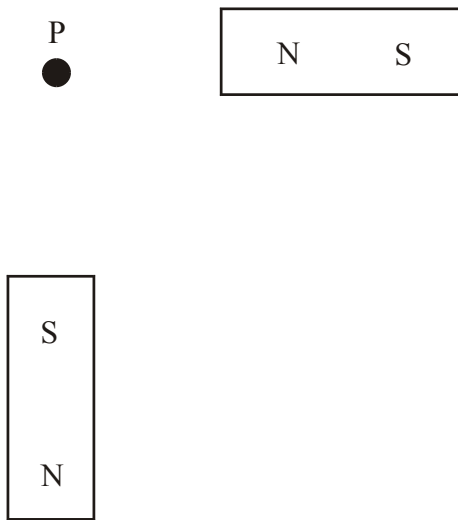

**Figure 9**

**Question 17**

Which one of the alternatives, **A – D** in **Figure 10**, best gives the direction of the net magnetic field at point P ?

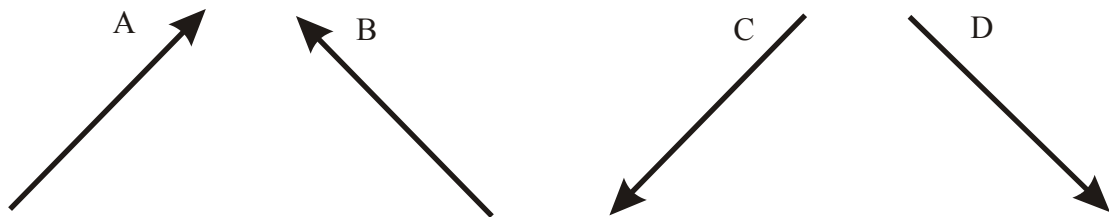
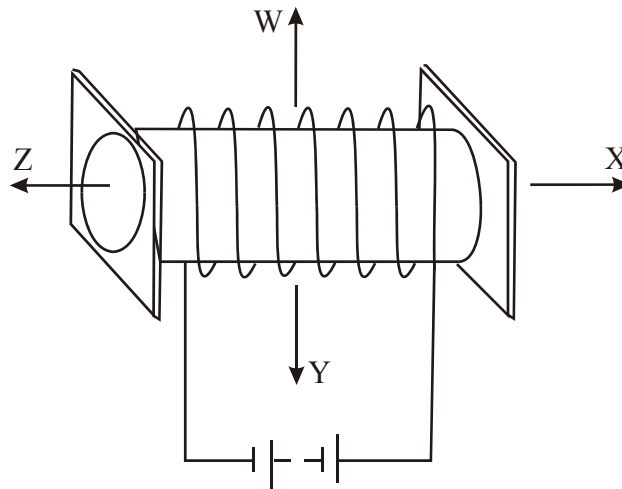

**Figure 10**

**(2 marks)**

**Question 18**

Which one of the arrows, **W - Z** in **Figure 11**, indicates the direction of the magnetic field inside the solenoid when the current is flowing?



**Figure 11**

**(2 marks)**

## Area of Study 2 – Interactions of Light and Matter

Questions 1 – 4 refer to the following information.

The maximum kinetic energy of the ejected photons plotted against the frequency of incident radiation on the surface of three different metals, sodium, magnesium and copper, is shown in **Figure 1**.

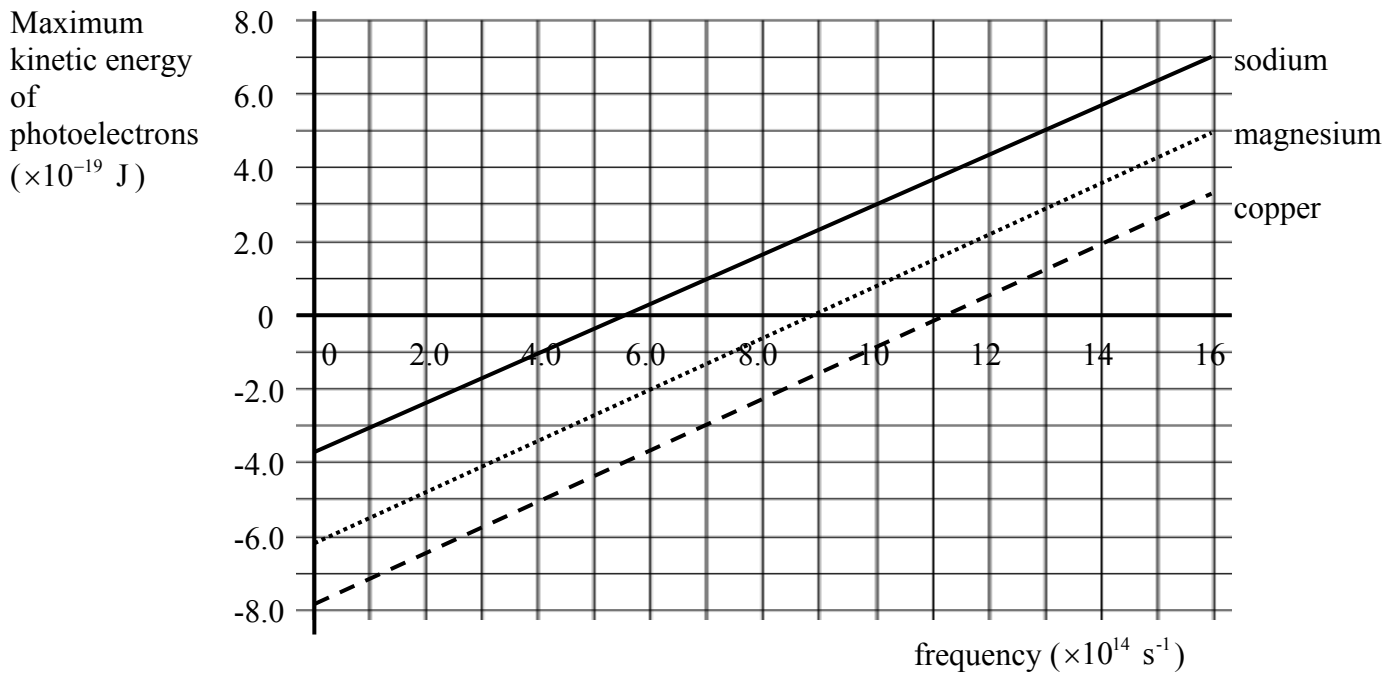

**Figure 1**

### Question 1

Use the graph in **Figure 1** to determine a value for Planck's constant. You must show your working.

J s
-----

**(2 marks)**

### Question 2

Calculate the minimum amount of energy, in eV, required to remove an electron from the surface of a piece of magnesium.

eV
----

**(3 marks)**

The work function for copper is 4.9 eV. Ultraviolet light of wavelength 200 nm is incident on a clean copper surface and the photoelectric effect is observed.

**Question 3**

Calculate the kinetic energy, in eV, of the fastest-moving ejected electrons.

eV

(3 marks)

**Question 4**

Calculate the cut-off potential for copper.

V

(1 mark)

The minimum photon energy necessary to eject electrons from a silver surface is about half of that required to eject electrons from a sodium surface.

**Question 5**

Which one of the graphs, A – D, in **Figure 2** best shows this fact? Justify your answer.

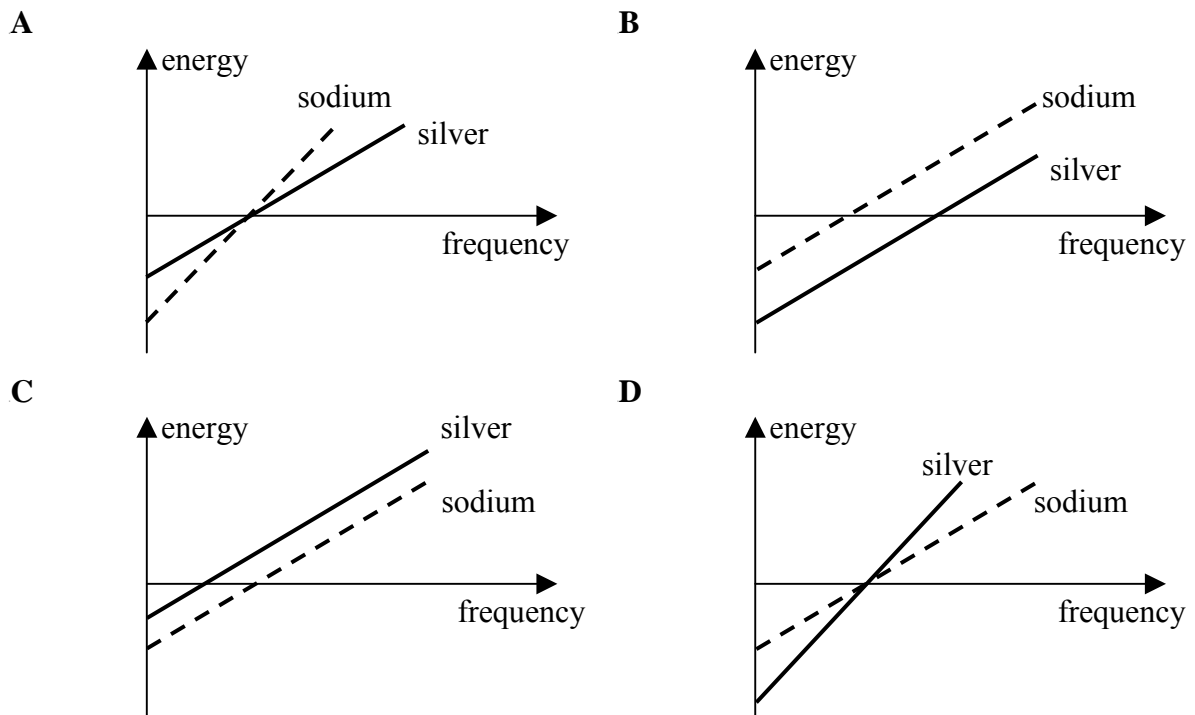

**Figure 2**

(3 marks)

**Figure 3** shows a photocell that can be used to determine the maximum energy of the emitted photoelectrons.

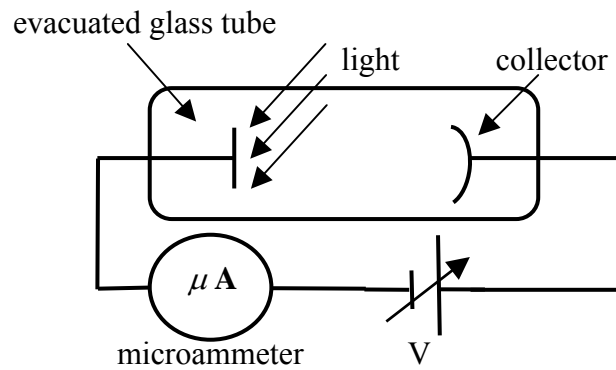

**Figure 3**

Questions 6 and 7 refer to the following information.

Monochromatic light shines onto a clean metal plate inside an evacuated glass tube as shown in **Figure 4**. When the voltage,  $V$ , between the plate and the collector is varied, the current measured by the microammeter varies as shown in **Figure 4**. The magnitude of the cut-off voltage is found to be 1.5 V.

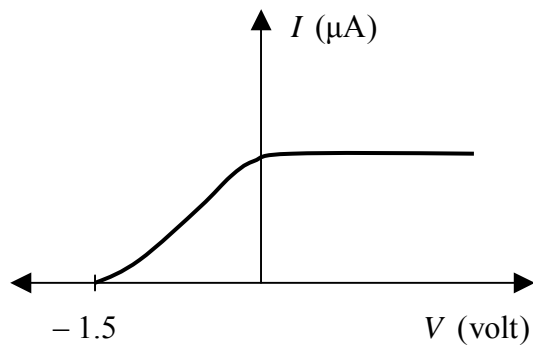

**Figure 4**

**Question 6**

Calculate the maximum kinetic energy, in J, of the electrons ejected from the plate.

J
---

**(2 marks)**

The light intensity is now increased.

**Question 7**

In terms of photon theory, explain how this will affect the magnitude of the cut-off voltage.

---

---

---

---

(3 marks)

Young's double slit experiment is set up by Gloria and Barbara in a dark laboratory as shown in **Figure 5**. Red light of wavelength 500 nm is shone onto the slits which are placed at a distance of about 2.0 m from the screen. The intensity pattern produced on the screen consists of light and dark bands.

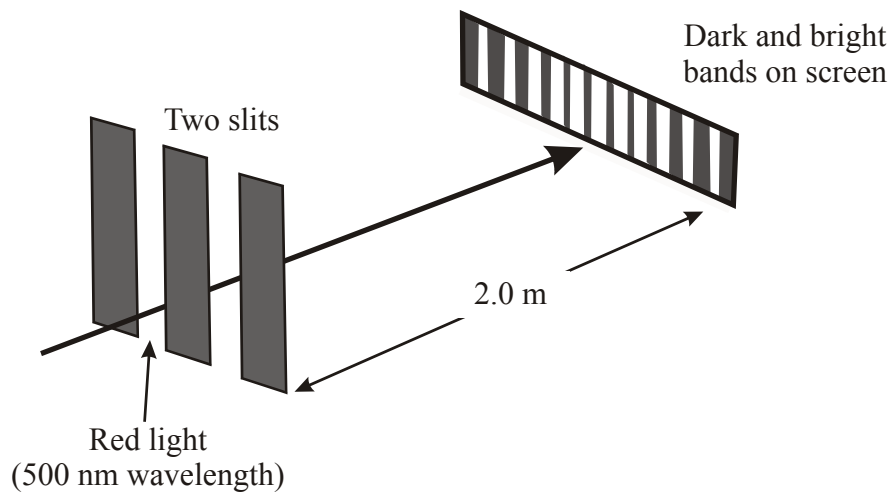

**Figure 5**

**Question 8**

Explain, giving reasons, whether the wave model or the particle model for light best describes the observations made.

---

---

---

(2 marks)

Gloria and Barbara use the same equipment but now use blue light with a wavelength of 400 nm and obtain another interference pattern similar to that for red light. The patterns observed with each coloured light are shown, in no particular order, in **Figure 6**.

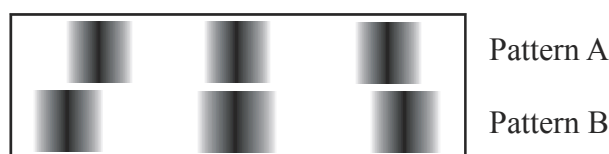

**Figure 6**



**Question 9**

Identify each pattern, A and B, as either that due to the red light or the blue light. Justify your answer.

pattern	colour
A	
B	

---

---

---

**(2 marks)**

*Questions 10 and 11 refer to the following information.*

The Bohr model of a hydrogen atom assumes that an electron is in a circular orbit around a proton. In the ground state the electron has an orbital radius of  $5.3 \times 10^{-11}$  m and a speed of  $2.2 \times 10^6$  m s<sup>-1</sup>

**Question 10**

Calculate the de Broglie wavelength, in nm, of an electron travelling at this speed.

nm
----

**(2 marks)**

**Question 11**

How many waves of this wavelength fit the circumference of the electron orbit? Show your working.

waves
-------

**(2 marks)**

**End of Section A**

## Section B – Detailed Study

### Detailed Study 3 – Sound

#### Question 1

Which one of the alternatives A – D, best describes how particles in a medium behave in a longitudinal wave?

- A. The particles of the medium are oscillating parallel to the direction of the wave motion.
- B. The particles of the medium are vibrating at right angles to the direction of the wave motion.
- C. The particles of the medium move in the direction of the wave motion.
- D. The particles of the medium are in phase and moving in opposite directions with the same speed.

(2 marks)

The following information refers to Questions 2 to 4.

**Figure 1** which shows how air pressure varies with time at a point near a musical instrument. The speed of sound in air at this time is  $340 \text{ m s}^{-1}$ .

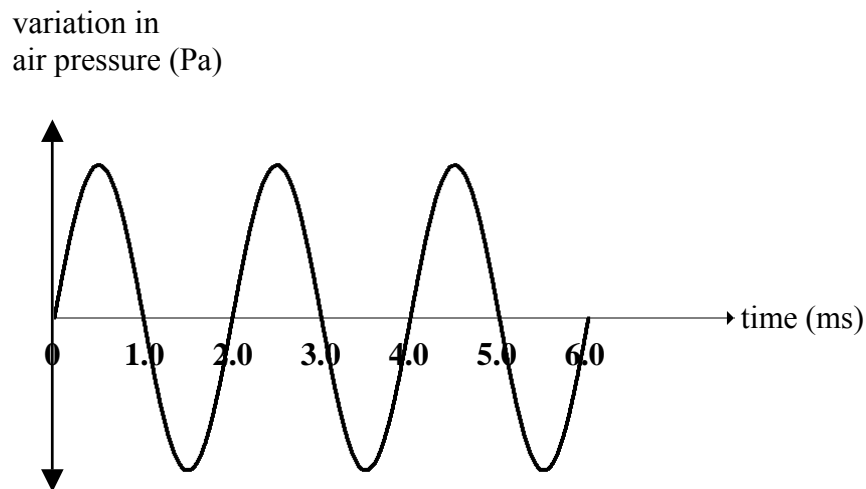

**Figure 1**

**Question 2**

Which one of the alternatives, A – D, gives the value of the period, in ms, of the sound produced by the musical instrument?

- A. 500
- B. 0.50
- C. 2.0
- D. 6.0

ms
----

(1 mark)

**Question 3**

Which one of the alternatives A – D gives the frequency, in Hz, of the sound produced by the musical instrument?

- A. 500
- B. 170
- C. 3.0
- D. 6.0

Hz
----

(2 marks)

**Question 4**

Which one of the alternatives A – D gives the wavelength, in m, of the sound produced by the musical instrument?

- A. 2.0
- B. 1.47
- C. 0.68
- D. 6.0

m
---

(2 marks)

*Questions 5 and 6 refer to the following information:*

A flute can be modelled as a pipe open at both ends. The lowest note that a flute can play is middle C, which has a frequency of 261.6 Hz. Assume that the speed of sound in air is  $340 \text{ ms}^{-1}$ .

**Question 5**

Which one of the alternatives A – D gives the length, in m, of the pipe that has a fundamental frequency of 261.6 Hz?

- A. 1.3
- B. 1.5
- C. 1.3
- D. 0.65

m
---

(2 marks)

**Figure 2** shows the distribution of air particles in the flute as it is resonating at one of its harmonics.

Antinodes occur along the flute and these points are indicated by the letter A.

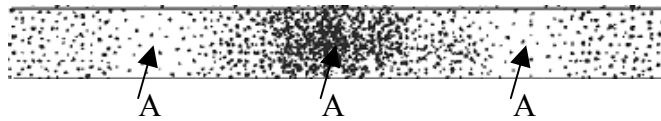

**Figure 2**

**Question 6**

Which one of the alternatives A – D gives the harmonic that is being played as shown in

**Figure 2?**

- A. First.
- B. Second.
- C. Third.
- D. Fifth.

**(2 marks)**

**Question 7**

Which one of the following choices, **A – D**, is correct?

Standing waves:

- A. are caused by waves of equal wavelength passing through a medium in opposite directions;
- B. are caused by waves of any wavelength passing through a medium in opposite directions;
- C. only occur in air;
- D. have a wavelength equal to the distance between adjacent nodes.

**(2 marks)**

*Questions 8 to 10 refer to the following information:*

The sound intensity of a siren at a distance of 5.0 m from the siren is measured to be  $1.2 \times 10^{-2} \text{ W m}^{-2}$ .

**Question 8**

Which one of the alternatives A – D gives the sound intensity level, in dB, at a distance of 5.0 m from the siren?

- A.  $1.2 \times 10^{10}$
- B. 100
- C. 10
- D. 1.9

**(2 marks)**

**Question 9**

Which one of the alternatives A – D gives the sound intensity, in  $\text{W m}^{-2}$ , at a distance of 10.0 m from the siren?

- A.  $6.0 \times 10^{-3}$
- B.  $3.0 \times 10^{-3}$
- C.  $4.8 \times 10^{-2}$
- D.  $3.0 \times 10^{-2}$

$\text{W m}^{-2}$
-------------------

**(2 marks)**

**Figure 3** shows the basic construction of a commonly used microphone.

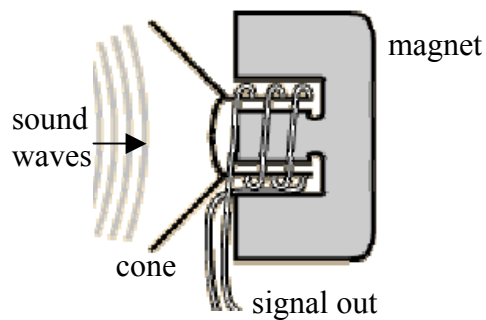

**Figure 3**

**Question 10**

Which one of the alternatives A – D identifies the type of microphone shown in **Figure 3**?

- A. Ribbon.
- B. Crystal.
- C. Dynamic.
- D. Condenser.

--

**(2 marks)**

A high fidelity loudspeaker is mounted on a baffle board as shown in **Figure 4**.

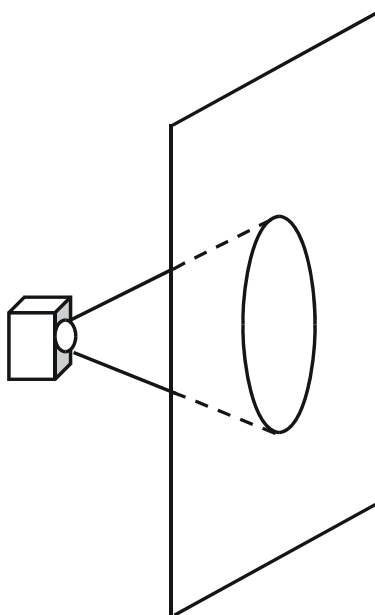

**Figure 4**

**Question 11**

Which one of the alternatives A – D gives the best explanation for using a baffle board to improve the performance of the loudspeaker system?

- A. The baffle board amplifies the sound because it increases the area of vibration.
- B. Sound waves produced at the back of the speaker are out of phase with sound waves produced at the front of the speaker and the baffle prevents interference of the waves.
- C. The baffle board prevents sound being lost to the rear of the speaker.
- D. The baffle board resonates at the same frequency as the sound waves from the speaker and increases the amplitude of the sound wave.

**(2 marks)**

Questions 12 and 13 refer to the following information.

Frequency response is a characteristic of all microphones. **Figure 5** shows the frequency response curve for one particular type of microphone.

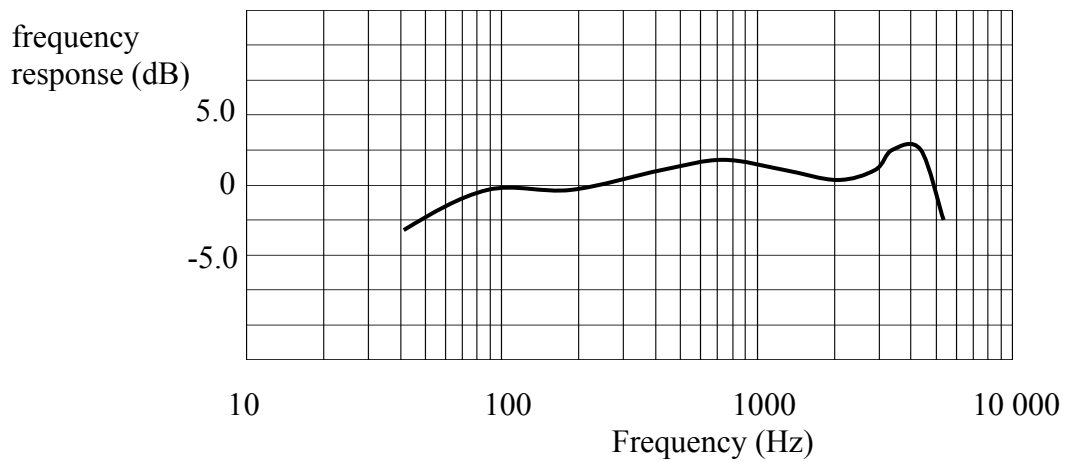

**Figure 5**

**Question 12**

Which one of the alternatives A – D best describes the ‘flat frequency response’ range for this microphone?

- A. 40 Hz – 100 Hz
- B. 100 Hz – 700 Hz
- C. 100 Hz – 3.0 kHz
- D. 4.0 kHz – 5.5 kHz

(2 marks)

**Question 13**

From the alternatives, A – D, choose the one which best states the frequency response of the microphone characteristics shown in **Figure 5**.

- A. 100 Hz – 2.0 kHz, +/- 3.0 dB
- B.  $\pm 3.0$  dB
- C. 40 Hz – 5.0 kHz, +/- 3.0 dB
- D. 40 Hz – 5.0 kHz, +/- 5.0 dB

(2 marks)

**End of Section B**

**End of Trial Exam**

## Suggested Answers VCE Physics 2008 Year 12 Trial Exam Unit 4

Section A core: Area of Study 1 – Electric power	Suggested Mark Allocation
<p><b>Question 1</b> Use the right-hand grip rule. The force will be into the page.</p> <div style="border: 1px solid black; display: inline-block; padding: 2px 5px;">E</div>	<p>1 1</p>
<p><b>Question 2</b> Use the formula; <math>F = BIl</math> <math>= 0.020 \times 2.5 \times 0.10</math> <math>= 5.0 \times 10^{-3} \text{ N}</math> Use the right-hand slap rule to determine the direction;</p> <div style="border: 1px solid black; display: inline-block; padding: 2px 5px;">C</div>	<p>2 1</p>
<p><b>Question 3</b> When the coil is in CC', the magnetic flux through the coil is a minimum.</p> <div style="border: 1px solid black; display: inline-block; padding: 2px 5px;">CC'</div>	<p>2</p>
<p><b>Question 4</b> The current produced by a constantly rotating coil connected to the slip rings would be sinusoidal. Answer:</p> <div style="border: 1px solid black; display: inline-block; padding: 2px 5px;">D</div>	<p>2</p>
<p><b>Question 5</b> From the graph, the period of the signal is; 0.20 s since; <math>T = \frac{1}{f}</math>; then <math>f = \frac{1}{0.20}</math> <math>= 5.0 \text{ Hz}</math></p>	<p>1 1</p>



<p><b>Question 6</b> Use;</p> $\varepsilon = -N \frac{\Delta\phi}{\Delta t}$ $= -N \frac{B\Delta\phi A}{\Delta t}$ $= -1 \times \frac{0.25 \times 0.050}{0.050}$ $= -0.25 \text{ V}$ <p>The magnitude of the average emf is 0.25 V</p>	<p>1</p> <p>1</p>
<p><b>Question 7</b> Induced voltage is produced by the time rate of change of magnetic flux through the coil. As the coil rotates at a constant rate, the area of the coil exposed to the magnetic field changes from a value of zero when the coil is parallel with the field to a maximum when the coil is perpendicular to the field. The induced emf will change from a maximum to zero. This produces an alternating voltage from positive to zero to negative to zero, then back to positive to complete the cycle.</p>	<p>1</p> <p>1</p> <p>1</p> <p>1</p>
<p><b>Question 8</b> Both A and D are correct.</p> <div style="border: 1px solid black; padding: 2px; display: inline-block;">A, D</div>	<p>1</p> <p>1</p>
<p><b>Question 9</b> The current enters the coil at Y, and flows in the direction B-C-D-A. Use the right-hand slap rule to determine the direction of the force.</p> <div style="border: 1px solid black; padding: 2px; display: inline-block;">A</div>	<p>1</p> <p>1</p>
<p><b>Question 10</b> The coil needs to continue rotating in the same direction. This means that the current in the coil must be reversed each half cycle. Each half of the split-ring commutator is connected to one end of the coil. The split-ring commutator changes the electrical contact on the wires as the momentum of the coil takes it past the vertical position. Brushes are used to make contact between the split-ring and the battery.</p>	<p>1</p> <p>1</p> <p>1</p>
<p><b>Question 11</b> Use;</p> $V_{PEAK} = V_{RMS} \times \sqrt{2}$ $= 240 \times \sqrt{2}$ $= 340 \text{ V}$	<p>1</p> <p>1</p>

<p><b>Question 12</b></p> <p>Use;</p> $\frac{V_1}{V_2} = \frac{N_1}{N_2}$ $V_1 = \frac{V_2 N_1}{N_2}$ <p><math>\frac{N_1}{N_2}</math> is the turns ratio, 45:1</p> $V_1 = 240 \times 45$ $V_1 = 10800 \text{ V}$ $V_1 = 11 \text{ kV}$	<p>1</p> <p>1</p>
<p><b>Question 13</b></p> <p>Use;</p> $P = VI$ $I = \frac{P}{V}$ $= \frac{20000}{240}$ $= 83.3 \text{ A}$ $= 83 \text{ A}$	<p>1</p> <p>1</p>
<p><b>Question 14</b></p> <p>Use;</p> $P_{\text{LOSS}} = I^2 R$ $= (83.3)^2 \times 0.150$ $= 1040 \text{ W}$ $= 1.0 \times 10^3 \text{ W}$	<p>1</p> <p>1</p>
<p><b>Question 15</b></p> <p>The total power available from the transformer is 20 kW.  The power loss in the transmission wires is 1040 W.  The current in the line is 83.3 A.</p> <p>Use;</p> $P = VI$ $V = \frac{P}{I}$ $= \frac{20000 - 1040}{83.3}$ $= 227.6 \text{ V}$ $= 230 \text{ V}$	<p>1</p> <p>1</p>

<p><b>Question 16</b> When an AC voltage is applied to the primary coil of a transformer, the changing magnetic field it produces will induce an AC voltage of the same frequency in the secondary coil. The voltage induced in the secondary coil will be different to the voltage in the primary coil if the respective number of turns in the primary and the secondary coils is different.</p>	1 1
<p><b>Question 17</b> The sum of the two magnetic field vectors from each magnet gives direction C. Answer C</p>	2
<p><b>Question 18</b> The direction of the magnetic field inside the solenoid is given by the letter Z. Answer Z.</p>	2
<p><b>Section A Core: Area of Study 2 – Interaction of Light &amp; Matter</b></p>	
<p><b>Question 1</b> Planck's constant is numerically equal to the gradient of an <math>E_{k \max}</math> v frequency graph. Select convenient points for calculation; eg</p> $\text{gradient} = \frac{\text{rise}}{\text{run}} \quad \text{for sodium}$ $= \frac{(7.0 - 0) \times 10^{-19}}{(16 - 5.5) \times 10^{14}}$ $= 6.7 \times 10^{-34} \text{ Js}$	1 1
<p><b>Question 2</b> The minimum amount of energy, in eV, required to remove an electron from a magnesium surface will be the energy of the photon with the threshold frequency for magnesium (<math>9.0 \times 10^{14} \text{ s}^{-1}</math>). Use; <math>E = hf</math> <math>= 6.6 \times 10^{-34} \times 9.0 \times 10^{14}</math> <math>= 5.94 \times 10^{-19} \text{ J}</math> <math>= \frac{5.94 \times 10^{-19}}{1.6 \times 10^{-19}}</math> <math>= 3.7 \text{ eV}</math></p>	1 1 1

<p><b>Question 3</b> The energy of the incident photon is;</p> $E_{\text{PHOTON}} = \frac{hc}{\lambda}$ $= \frac{4.14 \times 10^{-15} \times 3.0 \times 10^8}{200 \times 10^{-9}}$ $= 6.21 \text{ eV}$ $= 6.2 \text{ eV}$ <p>Using the photoelectric equation;</p> $E_{K \text{ max}} = hf - W$ $= 6.2 - 4.9$ $= 1.3 \text{ eV}$	<p>1</p> <p>1</p> <p>1</p>						
<p><b>Question 4</b> The cut-off potential will be 1.3 V when 1.3 eV of kinetic energy is taken from each electron.</p>	<p>1</p>						
<p><b>Question 5</b> Answer: B The gradients of the graphs for each metal must be the same. Silver has a higher threshold frequency</p>	<p>1</p> <p>2</p>						
<p><b>Question 6</b> The maximum energy, from the graph, is 1.5 eV. In joule;</p> $1.5 \times 1.6 \times 10^{-19}$ $= 2.4 \times 10^{-19} \text{ J}$	<p>1</p> <p>1</p>						
<p><b>Question 7</b></p> <ul style="list-style-type: none"> <li>The cut-off voltage remains the same.</li> <li>The energy of an ejected electron depends on the frequency of the photon.</li> </ul> <p>The frequency of the photon is related to the energy of the photon. Intensity of the light is related to the number of photons, not their energy.</p>	<p>1</p> <p>1</p> <p>1</p>						
<p><b>Question 8</b></p> <ul style="list-style-type: none"> <li>The wave model explains the interference pattern better.</li> <li>Maxima occur where waves from each slit arrive in phase due to a path difference of a whole number of wavelengths.</li> <li>Minima occur where waves from each slit arrive with path differences that are out of phase by a half wavelength.</li> </ul>	<p>Any two</p> <p>1</p> <p>1</p>						
<p><b>Question 9</b></p> <table border="1" data-bbox="608 1720 1166 1832"> <thead> <tr> <th>pattern</th> <th>colour</th> </tr> </thead> <tbody> <tr> <td>A</td> <td>red</td> </tr> <tr> <td>B</td> <td>blue</td> </tr> </tbody> </table> <p>The fringe width is directly proportional to the wavelength of the light. Red light has a longer wavelength than blue light. The peaks in the red interference pattern are further apart than in the blue interference pattern.</p>	pattern	colour	A	red	B	blue	<p>1</p> <p>1</p>
pattern	colour						
A	red						
B	blue						

<p><b>Question 10</b> Use; <math display="block">\lambda = \frac{h}{mv}</math> <math display="block">= \frac{6.6 \times 10^{-34}}{9.1 \times 10^{-31} \times 2.2 \times 10^6}</math> <math display="block">= 3.3 \times 10^{-10} \text{ m}</math> <math display="block">= 0.33 \text{ nm}</math></p>	<p>1  1</p>
<p><b>Question 11</b> The orbit radius is <math>5.3 \times 10^{-11} \text{ m}</math> The circumference of the orbit is; <math display="block">C = 2\pi r</math> <math display="block">= 2 \times \pi \times 5.3 \times 10^{-11}</math> <math display="block">= 3.3 \times 10^{-10} \text{ m}</math> <math display="block">\frac{C}{\lambda} = \frac{3.3 \times 10^{-10}}{3.3 \times 10^{-10}} = 1</math></p>	<p>1  1</p>
<b>Section B: Detailed Study – Sound</b>	
<p><b>Question 1</b> The particles of a medium oscillate parallel to the direction in which the wave is travelling. Answer A</p>	<p>2</p>
<p><b>Question 2</b> The period of the wave is 2.0 ms as shown on the graph. Answer C</p>	<p>1</p>
<p><b>Question 3</b> Use; <math display="block">f = \frac{1}{T}</math> <math display="block">= \frac{1}{2.0 \times 10^{-3}}</math> <math display="block">= 500 \text{ Hz}</math> Answer A</p>	<p>2</p>
<p><b>Question 4</b> Use; <math display="block">v = f\lambda</math> <math display="block">\lambda = \frac{v}{f}</math> <math display="block">= \frac{340}{500}</math> <math display="block">= 0.68 \text{ m}</math> Answer C</p>	<p>2</p>

<p><b>Question 5</b>  For a pipe open at both ends:  <math>\lambda = 2L</math>  <math>L = \frac{\lambda}{2}</math>  <math>\lambda = \frac{v}{f}</math>  <math>\frac{340}{261.6}</math>    = 1.30 m  <math>L = \frac{1.30 \text{ m}}{2}</math>  = 0.65 m  Answer <b>D</b></p>	2
<p><b>Question 6</b>  The pipe is open at both ends and shows 3 antinodes (and 4 nodes).  Therefore it is the third harmonic.  Answer <b>C</b></p>	2
<p><b>Question 7</b>  Answer <b>A</b>.</p>	2
<p><b>Question 8</b>    <math>I_1 = 1.2 \times 10^{-2} \text{ W m}^{-2}</math>  <math>L = 10 \log_{10} \frac{I_1}{I_0}</math>    = <math>10 \log_{10} \frac{1.2 \times 10^{-2}}{1.0 \times 10^{-12}}</math>  = 100 dB  Answer <b>B</b></p>	2
<p><b>Question 9</b>  <math>I_1 = 1.2 \times 10^{-2} \text{ W m}^{-2}</math>, <math>I_2 = ?</math>  <math>r_1 = 5.0 \text{ m}</math>, <math>r_2 = 10.0 \text{ m}</math>  Use;  <math>I_2 = \frac{r_1^2 I_1}{r_2^2}</math>  = <math>\frac{(5.0 \text{ m})^2 \times 1.2 \times 10^{-2}}{(10.0 \text{ m})^2}</math>  = <math>3.0 \times 10^{-3} \text{ W m}^{-2}</math>  Answer <b>B</b></p>	2

<p><b>Question 10</b> Principle: sound moves the cone and the attached coil of wire moves in the field of a magnet. The generator effect produces a voltage which "images" the sound pressure variation. A dynamic microphone is characterized as a pressure microphone. Answer <b>C</b></p>	2
<p><b>Question 11</b> The baffle board prevents destructive interference of front and back waves which are out of phase. Answer <b>B</b></p>	2
<p><b>Question 12</b> An ideal "flat" frequency response means that the microphone is equally sensitive to all frequencies in the given range. In this case, the frequency response chart would be a flat line, or nearly so, resulting in a more accurate representation of the original sound in that section of the chart. Answer <b>C</b></p>	2
<p><b>Question 13</b> Answer <b>C</b> 40 Hz – 5.0 kHz, +/- 3.0 dB</p>	2

### End of Suggested Answers