

VICTORIA UNIVERSITY PRESENTS THE...

2011 VCE LECTURE SERIES

HEALTH, ENGINEERING AND SCIENCE

VCE CHEMISTRY
UNIT 4: CHEMISTRY AT WORK

SAMPLE EXAM QUESTIONS

DATE: THURSDAY 29 SEPTEMBER 2011
Prepared by: Neale Peters

BACHELOR OF INFORMATION TECHNOLOGY (NETWORK AND SYSTEMS COMPUTING) VTAC code 40811

The Bachelor of Information Technology (Network and Systems Computing) prepares students for a graduate level position within the IT industry. Currently there is a growing market need for graduates skilled in systems administration with networking expertise and this degree equips students with the knowledge and skills required. The program prepares students for IT Industry Certifications (CISCO/Microsoft) and for a career in the fields of networking, databases, and systems administration. The course is offered over three years on a full-time basis (part-time equivalent) at the Footscray Park Campus. With the skills you develop, you could be looking at a range of career options in:

Business Analysis & Consulting
Computing & Network Support
Database Administration
Network & Systems Administration
Project Management
Secondary Teaching
Systems Security Consultancy
Web-based Programming

Prerequisites: Units 3 and 4 – a study score of at least 20 in English (any) and ANY Mathematics.

BACHELOR OF ENGINEERING SCIENCE (SPORTS ENGINEERING) VTAC code 40881

Bachelor of Engineering Science (Sports Engineering) prepares students for a career in the fields of sports, sports science, and exercise and rehabilitation. The primary objective of this program is to produce graduates who are universally recognised as leading practitioners in their field and who, as Sports Engineers, are capable of making a contribution to society and the community.

This program develops students into highly skilled engineering technologists who will be able to provide knowledge-based practical engineering services/solutions to the sports, sports science, and exercise and rehabilitation industries. The course is offered over three years on a full-time basis and will take full advantage of the new \$53 million specialist Sports and Exercise Sciences complex at the Footscray Park campus. With the skills you develop, you could be looking at a range of career options such as:

Scientists
Coaches
Elite Athletes
Sporting Goods Manufacturers
Venue Managers

Prerequisites: Units 3 and 4—a study score of at least 24 in English (any) and in one of further mathematics, mathematical methods or specialist mathematics.

BACHELOR OF SCIENCE (Specialisations in Biotechnology, Chemistry or Environmental Management) VTAC code 40691

We produce graduates with a thorough knowledge of contemporary science for careers in industry, government and education. If you want to be a: biotechnologist; chemist; ecologist or environmental scientist; the Bachelor of Science (Specialisation) is the course for you.

The course offers major studies in the abovementioned professions, where students can choose to specialise in one or two science disciplines. This is a three year course with elective choices in the latter two years that allows students the flexibility to add other studies of interest to their specialisation. Specialisations are offered subject to student numbers.

Science at Victoria University is industry focussed, offers an intensive hands-on laboratory experience, has modern laboratories with state-of-the-art equipment, provides opportunities for industry projects and placements and overall better prepares students for careers in the science profession. Those students with scientific research in mind can progress into Honours and postgraduate studies.

Prerequisites: Units 3 and 4 – a study score of at least 20 in English (any) and ANY Mathematics.

SCHOLARSHIPS ENTER AT 70

Available for all Engineering, IT (networking and systems computing), Science Specialisation and Nutrition, Health and Food Sciences courses for students with an ATAR (Enter) of 70 and above who meet the requirements.

See www.vu.edu.au/hes for more information and application form.

ALTERNATIVE ENTRY FOR ENGINEERING (VTAC code 41441) SCIENCE (VTAC code 41451)

Alternative entry program to engineering and science courses for students who have:

- Successfully completed year 12 with the required prerequisites, but may not have achieved the required study score in all prerequisites; or
- Have not studied the required mathematics prerequisite.

All admissions are on an individual basis. All applicants offered a place would be required to enroll in one or more subjects from the Foundation Year.

Prerequisites: Units 3 and 4 – English (any) and mathematics (any). ATAR (ENTER) 50+

Question 4

The graph below represents the energy changes over the course of a chemical reaction

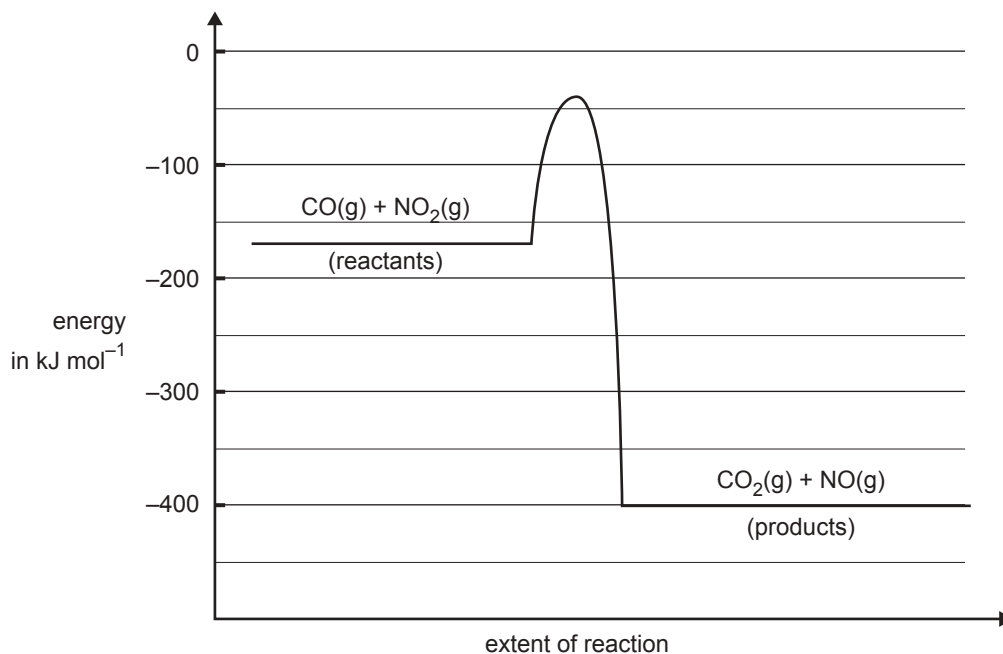
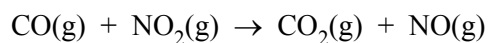

- a. Give the magnitude and sign of the ΔH for the forward reaction in kJ mol^{-1} .

1 mark

- b. Give the activation energy for the reverse reaction in kJ mol^{-1} .

1 mark

- c. Give two reasons explaining why the rate of this reaction increases with increasing temperature.

2 marks

- d. A suitable catalyst is discovered for the reaction. What would be the likely effect of the catalyst on
- the activation energy? Explain your answer.

- the ΔH ? Explain your answer.

1 + 1 = 2 marks

Total 6 marks

Question 6

Dinitrogen tetroxide (N_2O_4) is a colourless gas. It exists in equilibrium with nitrogen dioxide (NO_2), a brown gas. The concentration of NO_2 in a gas mixture can be determined using a spectrophotometer. The equation for the reaction is

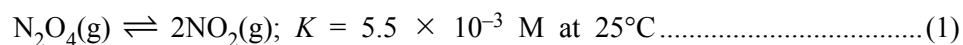

- a. Write the expression for the equilibrium constant for this reaction.

1 mark

- b. Some pure NO_2 is placed in a gas syringe at 25°C and allowed to reach equilibrium.

- i. Keeping the volume constant the temperature is then raised to 35°C . The brown colour then becomes more intense. Is the above reaction (1) exothermic or endothermic? Explain your answer.

- ii. Keeping the temperature at 35°C the plunger of the syringe is then pushed in so as to halve the volume. Equilibrium is then re-established. Is the brown colour of the mixture more intense or less intense than before the volume was halved?

2 + 1 = 3 marks

- c. Give the numerical value at 25°C of the equilibrium constant of the reaction

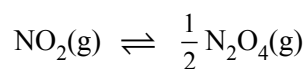

2 marks

Total 6 marks

Question 5

a. The hydrogen carbonate ion (HCO_3^-) can act both as an acid and as a base.

i. Write a chemical equation that shows HCO_3^- acting as an acid when it reacts with water.

ii. Write a chemical equation that shows HCO_3^- acting as a base when it reacts with water.

1 + 1 = 2 marks

b. Hypochlorous acid (HOCl) is a weak acid with an acidity constant, K_a , of 3.0×10^{-8} M at 25°C . Calculate the pH of a 0.50 M solution of hypochlorous acid at that temperature.

3 marks

c. The hydrogen ion concentration of a solution is described by the term pH. The hydroxide ion (OH^-) concentration is described in the same way by the term pOH.

A solution has a pOH of 3 at 25°C .

i. Calculate the **hydroxide ion** concentration of the solution, in mol L^{-1} .

ii. Calculate the **hydrogen ion** concentration of the solution, in mol L^{-1} .

1 + 1 = 2 marks

Total 7 marks

Question 3

The energy content of food can be determined by completely burning a sample of the food in a bomb calorimeter and then calculating the energy released.

- a. The calorimeter must first be calibrated by passing an electric current through the calorimeter for a known period of time and measuring the resultant temperature rise. The data relevant to such a calibration is given below.

Current	1.78 A
Potential difference	5.65 V
Time	135 s
Temperature rise	1.15°C

Use the data above to calculate the calibration factor, in $\text{kJ } ^\circ\text{C}^{-1}$, for this calorimeter.

2 marks

- b. The carbohydrate, glucose, burns in excess oxygen according to the following equation.

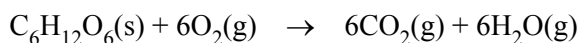

When a 1.324 g sample of glucose was burned in the calorimeter calibrated in part a. above, the temperature increased from 18.23°C to 35.55°C.

Calculate the molar heat of combustion of glucose in kJ mol^{-1} .

3 marks

- c. The carbohydrate, sucrose, is a disaccharide. Predict the approximate value of the ratio

$$\frac{\text{molar heat of combustion sucrose}}{\text{molar heat of combustion glucose}}$$

Approximate value of the above ratio is _____

Explain your reasoning.

2 marks

Total 7 marks

SECTION B – continued

Question 2

Some atoms of element X in a discharge tube are found to have the electron configuration $1s^2 2s^2 2p^4 4s^1$.

- a. Give the name, or the chemical symbol, of element X.

1 mark

- b. If the electron configuration changed from $1s^2 2s^2 2p^4 4s^1$ to $1s^2 2s^2 2p^4 3s^1$, would the process be exothermic or endothermic? Explain your reasoning.

2 marks

- c. Write the ground state electron configuration for atoms of element X.

1 mark

Total 4 marks

problem 5 : 2004-2 Q3**Question 3**

- a. A bomb calorimeter may be calibrated using a substance with a well-known heat of combustion. A commonly used calibrating agent is benzoic acid ($C_7H_6O_2$) which has a heat of combustion of 3227 kJ for each mole of benzoic acid.

- i. 2.50 g of pure solid benzoic acid is placed in a calorimeter and completely reacted with oxygen. The temperature rise of the calorimeter is observed to be $8.90^\circ C$.

Calculate the calibration factor of the calorimeter in $kJ^\circ C^{-1}$.

3 marks

- ii. Give a chemical equation for the reaction of benzoic acid with oxygen. Include the **correct sign and magnitude** of the ΔH for the reaction.

3 marks

- b. A second bomb calorimeter is used for the following two experiments. The calibration factor for this calorimeter is $5.56 \text{ kJ}^\circ\text{C}^{-1}$.

A lump of lignite (brown coal) is freshly taken from the ground and crushed into a powder.

Two samples of this powdered lignite are weighed. Each sample has a mass of 3.20 g.

- i. Sample 1 is placed in the calorimeter and completely reacted with oxygen.

The temperature rise of the calorimeter is found to be 2.21°C .

Calculate the heat of combustion of the fresh lignite in kJ g^{-1} .

2 marks

- ii. Sample 2 is placed in an oven for 2 hours where it is kept at a temperature of 100°C .

It is cooled and weighed. Its mass decreases to 2.15 g after heating.

It is then completely reacted with oxygen in the calorimeter.

The temperature rise of the calorimeter is found to be 2.66°C .

Explain why the combustion of the second sample of lignite appears to release significantly more energy than the first sample.

1 mark

Total 9 marks

Question 7

The following diagram represents a $\text{H}^+(\text{aq})/\text{H}_2(\text{g})$ half cell for the reaction

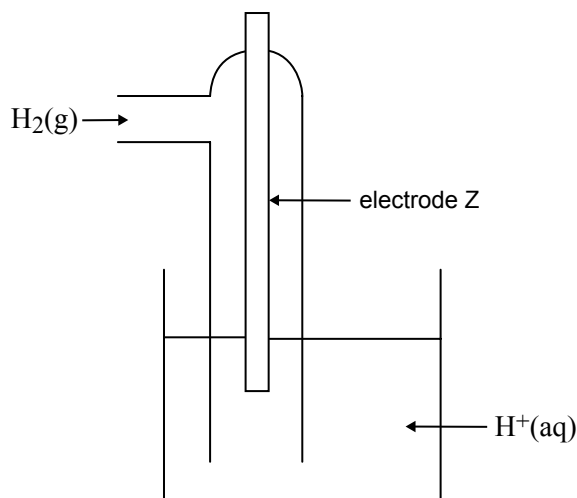
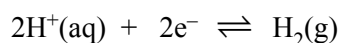

- a. i. For this half cell, identify an appropriate material for electrode Z.

- ii. For this half cell to be a **standard** half cell, state

- the temperature at which it must operate _____
- the required **pH** of the solution of $\text{H}^+(\text{aq})$ ions _____

1 + 2 = 3 marks

- b. A galvanic cell consists of the following half cells which have been set up under standard conditions.

- Half cell 1: the $\text{H}^+(\text{aq})/\text{H}_2(\text{g})$ half cell described in **part a**.
- Half cell 2: a cadmium (Cd) electrode in a solution containing $\text{Cd}^{2+}(\text{aq})$

After some time, the pH in half cell 1 has increased. Use this information to identify the species in this galvanic cell which is the stronger reductant and explain how you reached this conclusion.

The stronger reductant is _____

Explanation _____

2 marks

c. A second galvanic cell consists of the following half cells.

- Half cell 1: an inert electrode in 100.0 mL solution of 1.00 M $X^{2+}(aq)$
- Half cell 2: an electrode of $Cu(s)$ in 100.0 mL solution of 1.00 M $Cu^{2+}(aq)$

This galvanic cell is shown in the diagram below.

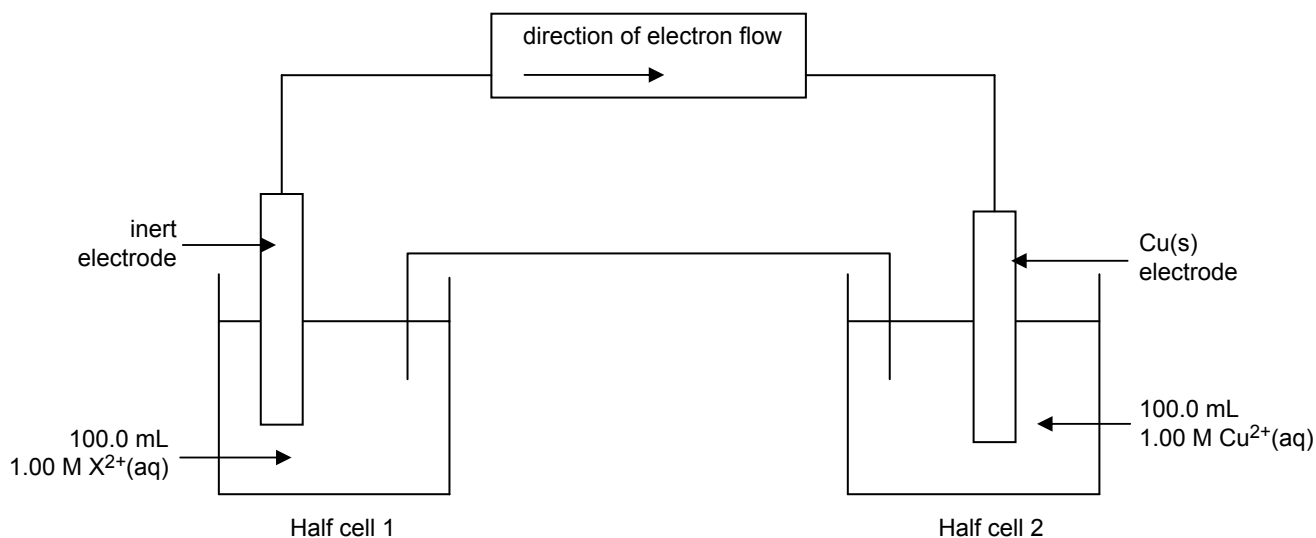

After discharging 2654 C of electricity, the concentration of the $X^{2+}(aq)$ in solution in half cell 1 was found to be 0.725 M. The volume of the solutions in the two half cells had not changed.

- i. Calculate the amount, in mol, of $X^{2+}(aq)$ that reacted in half cell 1.

- ii. Calculate the ratio of $n(X^{2+})$ reacted to $n(e^-)$ that passed through the cell.

That is, calculate: $n(X^{2+})_{\text{reacted}} : n(e^-)$

- iii. State the oxidation state of the product of the half reaction in half cell 1.

- iv. Write an equation for the half reaction that occurred at the electrode of half cell 1.

2 + 2 + 1 + 1 = 6 marks

Total 11 marks

SECTION B – continued
TURN OVER

- b. A rechargeable galvanic cell, also based on nickel and cadmium (NiCd cell), has been commercially available for a number of years and has been used to power small appliances such as mobile phones. A simplified diagram of a NiCd cell is given below.

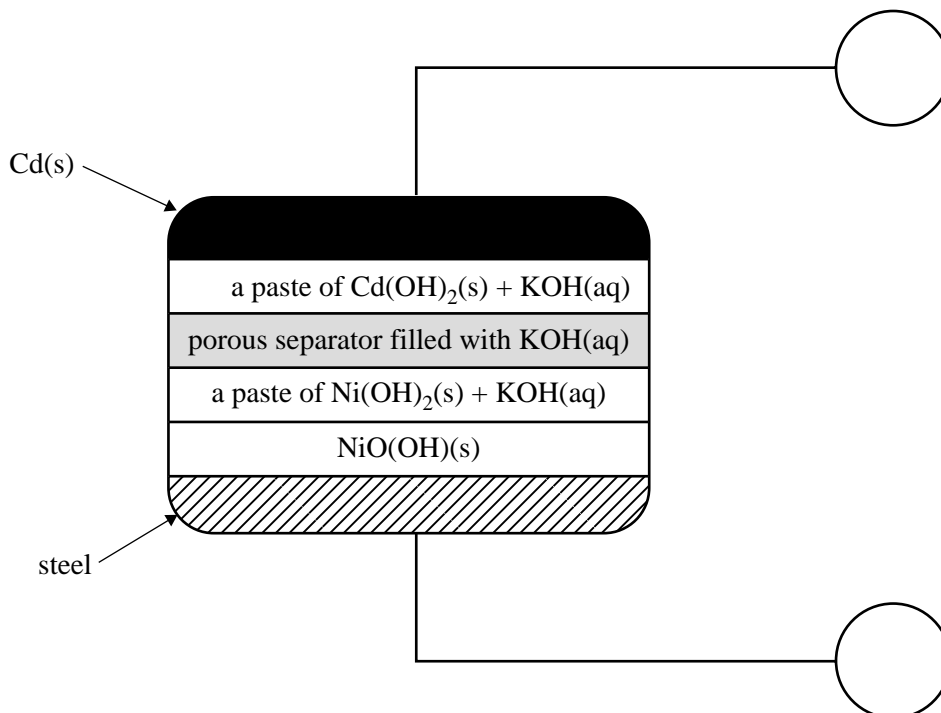

The overall cell reaction for the cell when discharging is

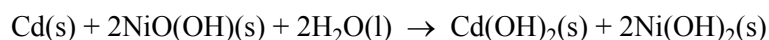

- i. Identify the positive and the negative electrodes by writing '+' or '-' in the circles provided in the diagram.
- ii. What feature of this secondary cell enables it to be recharged?

- iii. Give the equation for the half reaction that takes place at the negative electrode when the cell is discharging.

- iv. Give the equation for the half reaction that takes place at the electrode connected to the negative terminal of the power supply when the cell is recharging.

1 + 1 + 1 + 1 = 4 marks

Total 8 marks

problem 8: 2002-2 Q6

Question 6

An isolated research station is to be staffed by a small group of scientists for 13 weeks. Part of the exercise is to test the effectiveness of liquid ethanol ($\text{CH}_3\text{CH}_2\text{OH}$) as a source of fuel under these conditions. It is planned to use two different methods of generating energy from the ethanol.

- a. Some of the ethanol is to be directly burnt for heating and cooking, using the reaction

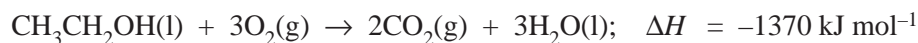

The average need for heating and cooking over the 13-week period is 800 MJ per week. Calculate the total mass of ethanol needed to satisfy the heating and cooking requirements of the research station.

$$1 \text{ MJ} = 10^3 \text{ kJ}$$

3 marks

- b. Some ethanol may also be used for electric power for lighting, refrigeration, computing and other electronic equipment. This can be provided by a fuel cell with an acidic electrolyte, whose cell reaction is identical to the equation given above. In the fuel cell the cathode reaction is

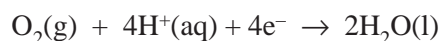

The voltage across the fuel cell is 1.15 V.

- i. Give the half reaction occurring at the anode where the ethanol is oxidised in the fuel cell.

- ii. Calculate the electrical energy provided per mole of ethanol consumed in the fuel cell.

1 + 2 = 3 marks

- c. An alternative way of generating electricity from ethanol is to use it as the fuel for an internal combustion engine driving a generator.

Suggest one important reason why the fuel cell would be better than the generator for this purpose.

1 mark

Question 7

A mineral ore contains a mixture of compounds of lead and calcium, in approximately equal proportions. A chemist extracts the metal ions by roasting the ore in air and treating the product with acid. The solution that contains the $\text{Pb}^{2+}(\text{aq})$ and $\text{Ca}^{2+}(\text{aq})$ is then placed in an electrolytic cell as shown in the diagram below.

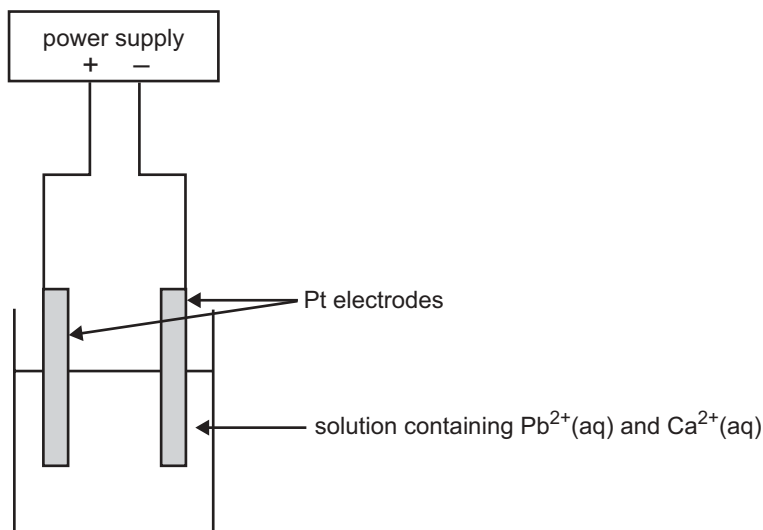

a. Label the anode and cathode of the cell.

1 mark

b. When the current begins to flow in the cell, write equations for the half reaction that is likely to occur at the

- positive electrode

- negative electrode

2 marks

c. After some time has elapsed, a new half reaction occurs at one of the electrodes. Write the equation for this half reaction.

1 mark

d. If the chemist had used copper electrodes instead of platinum electrodes, how would this have affected the half reaction at the anode?

1 mark

Total 5 marks

VICTORIA UNIVERSITY 2011

CHANGE OF PREFERENCE 16-21 DECEMBER

DROP INTO VUHQ - CITY FLINDERS CAMPUS, ONLINE CHAT SERVICE & COURSE HOTLINE: 1300 VIC UNI

Friday 16	8:30AM - 5:30PM
Saturday 17	11:00AM - 4:00PM
Sunday 18	11:00AM - 4:00PM
Monday 19	8:30AM - 5:30PM
Tuesday 20	8:30AM - 5:30PM

GENERAL INFORMATION SESSIONS

Monday 19	4:00PM - 7:00PM
Tuesday 20	4:00PM - 7:00PM

Footscray Park Campus
Ballarat Road, Footscray
Melways Ref. Map 42 C2

CAMPUS TOURS

Footscray Park tours will operate after each information session.

vu.edu.au

CRICOS Provider No. 00124K

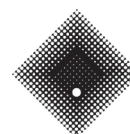

**VICTORIA
UNIVERSITY**

MELBOURNE AUSTRALIA