

CHEMISTRY

UNIT 3

Student name Student ID Letter **Structure of book**

Section	Number of questions	Number of marks
A	20	20
B	7	65
Total		85

- Students are permitted to bring into the examination room: pens, pencils, highlighters, erasers, sharpeners, rulers and an approved scientific calculator.
- Students are NOT permitted to bring into the examination room: blank sheets of paper and/or white out liquid/tape.

Materials supplied

- Question and answer book of 17 pages with a detachable answer sheet for multiple-choice questions inside the front cover.

Instructions

- Detach the answer sheet for multiple-choice questions during reading time.
- Write your name and student ID in the space provide above on this page and on the answer sheet for multiple-choice questions.
- All written responses should be in English.

At the end of the examination

- Place the answer sheet for multiple-choice questions inside the front cover of this book.



Published by STAV
© STAV May 2024

STAV House, 5 Munro Street,
Coburg VIC 3058 Australia

PHONE: 61 + 3 9385 3999
EMAIL: admin@stav.vic.edu.au
ABN: 59 004 145 329

All rights reserved. Except under the conditions described in the Copyright Act 1968 of Australia and subsequent amendments, no part of this publication may be reprinted, reproduced or utilised in any form or by any electronic, mechanical, or other means, now known or hereafter invented, including photocopying and recording, or in any other information storage or retrieval system, without permission in writing from the publisher.

stav.org.au/stav-publishing

STAV

2024

CHEMISTRY

Unit 3 Trial Examination

MULTIPLE CHOICE ANSWER SHEET

STUDENT NAME:	
------------------	--

INSTRUCTIONS:	USE PENCIL ONLY
<ul style="list-style-type: none">• Write your name in the space provided above.• Use a PENCIL for ALL entries.• If you make a mistake, ERASE it – DO NOT cross it out.• Marks will NOT be deducted for incorrect answers.• NO MARK will be given if more than ONE answer is completed for any question.• Mark your answer by SHADING the letter of your choice.	

	ONE ANSWER PER LINE		ONE ANSWER PER LINE
1	<input type="checkbox"/> A <input type="checkbox"/> B <input type="checkbox"/> C <input type="checkbox"/> D	11	<input type="checkbox"/> A <input type="checkbox"/> B <input type="checkbox"/> C <input type="checkbox"/> D
2	<input type="checkbox"/> A <input type="checkbox"/> B <input type="checkbox"/> C <input type="checkbox"/> D	12	<input type="checkbox"/> A <input type="checkbox"/> B <input type="checkbox"/> C <input type="checkbox"/> D
3	<input type="checkbox"/> A <input type="checkbox"/> B <input type="checkbox"/> C <input type="checkbox"/> D	13	<input type="checkbox"/> A <input type="checkbox"/> B <input type="checkbox"/> C <input type="checkbox"/> D
4	<input type="checkbox"/> A <input type="checkbox"/> B <input type="checkbox"/> C <input type="checkbox"/> D	14	<input type="checkbox"/> A <input type="checkbox"/> B <input type="checkbox"/> C <input type="checkbox"/> D
5	<input type="checkbox"/> A <input type="checkbox"/> B <input type="checkbox"/> C <input type="checkbox"/> D	15	<input type="checkbox"/> A <input type="checkbox"/> B <input type="checkbox"/> C <input type="checkbox"/> D
6	<input type="checkbox"/> A <input type="checkbox"/> B <input type="checkbox"/> C <input type="checkbox"/> D	16	<input type="checkbox"/> A <input type="checkbox"/> B <input type="checkbox"/> C <input type="checkbox"/> D
7	<input type="checkbox"/> A <input type="checkbox"/> B <input type="checkbox"/> C <input type="checkbox"/> D	17	<input type="checkbox"/> A <input type="checkbox"/> B <input type="checkbox"/> C <input type="checkbox"/> D
8	<input type="checkbox"/> A <input type="checkbox"/> B <input type="checkbox"/> C <input type="checkbox"/> D	18	<input type="checkbox"/> A <input type="checkbox"/> B <input type="checkbox"/> C <input type="checkbox"/> D
9	<input type="checkbox"/> A <input type="checkbox"/> B <input type="checkbox"/> C <input type="checkbox"/> D	19	<input type="checkbox"/> A <input type="checkbox"/> B <input type="checkbox"/> C <input type="checkbox"/> D
10	<input type="checkbox"/> A <input type="checkbox"/> B <input type="checkbox"/> C <input type="checkbox"/> D	20	<input type="checkbox"/> A <input type="checkbox"/> B <input type="checkbox"/> C <input type="checkbox"/> D

SECTION A – Multiple-choice questions (20 marks)**Instructions for Section A**

Answer **all** questions on the answer sheet provided for multiple-choice questions.

Choose the response that is **correct** or that **best answers** the question.

A correct answer scores 1; an incorrect answer scores 0.

Marks will **not** be deducted for incorrect answers.

No marks will be given if more than one answer is completed for any question.

Unless otherwise indicated, the diagrams in this book are **not** drawn to scale.

Question 1

Which one of the following statements best describes the renewability of biogas?

- A. Biogas is a renewable resource as it releases less carbon dioxide gas into the atmosphere when combusted than natural gas.
- B. Biogas is non-renewable as it is produced from fossil fuels that take millions of years to replace.
- C. Biogas is renewable as it is generated from the anaerobic breakdown of organic matter that can be replaced within a relatively short period of time.
- D. Biogas is renewable as it is generated by fermentation of sugars, by yeast, from recently living plants that can be replaced within a relatively short period of time.

Question 2

16 kg of octane undergoes complete combustion at SLC. The volume of greenhouse gases produced is closest to

- A. 3.5 L
- B. 28 L
- C. 3.5×10^3 L
- D. 2.8×10^4 L

Question 3

In an endothermic reaction, how do the relative bond strengths in the reactants compare to those in the products?

- A. The bond strengths in the reactants are weaker than those in the products.
- B. The bond strengths in the reactants are stronger than those in the products.
- C. The bond strengths in the reactants are equal to those in the products.
- D. The relative bond strengths in the reactants and products vary depending on the specific reaction.

Question 4

Which of the following equations represents an endothermic process?

- A. $\text{C}_6\text{H}_{12}\text{O}_6(\text{aq}) + 6\text{O}_2(\text{g}) \rightarrow 6\text{CO}_2(\text{g}) + 6\text{H}_2\text{O}(\text{l})$
- B. $\text{C}_3\text{H}_6(\text{g}) + 3\text{O}_2(\text{g}) \rightarrow 3\text{CO}(\text{g}) + 3\text{H}_2\text{O}(\text{g})$
- C. $\text{NH}_3(\text{g}) \rightarrow \text{NH}_3(\text{l})$
- D. $\text{I}_2(\text{s}) \rightarrow \text{I}_2(\text{g})$

Question 5

Consider the thermochemical equations below.

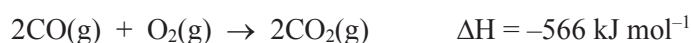

The ΔH value for the reaction $2\text{C}(\text{s}) + \text{O}_2(\text{g}) \rightarrow 2\text{CO}(\text{g})$ is closest to

- A. $+173 \text{ kJ mol}^{-1}$
- B. -220 kJ mol^{-1}
- C. -959 kJ mol^{-1}
- D. $-1352 \text{ kJ mol}^{-1}$

Question 6

The calibration factor for a calorimeter and its contents is $480 \text{ J } ^\circ\text{C}^{-1}$. When 0.040 mol of KNO_3 was dissolved in 100 mL of water in the calorimeter, the temperature of the water decreased by 2.90°C . The calculated enthalpy of dissolution of KNO_3 is closest to

- A. -1.4 kJ mol^{-1}
- B. $+1.4 \text{ kJ mol}^{-1}$
- C. -35 kJ mol^{-1}
- D. $+35 \text{ kJ mol}^{-1}$

Question 7

In a primary cell when discharging

- A. oxidation occurs at the anode which is positively charged.
- B. oxidation occurs at the anode which is negatively charged.
- C. oxidation occurs at the cathode which is positively charged.
- D. oxidation occurs at the cathode which is negatively charged.

Question 8

Consider the galvanic cell below, operating at standard conditions. The voltmeter reads 1.00 V.

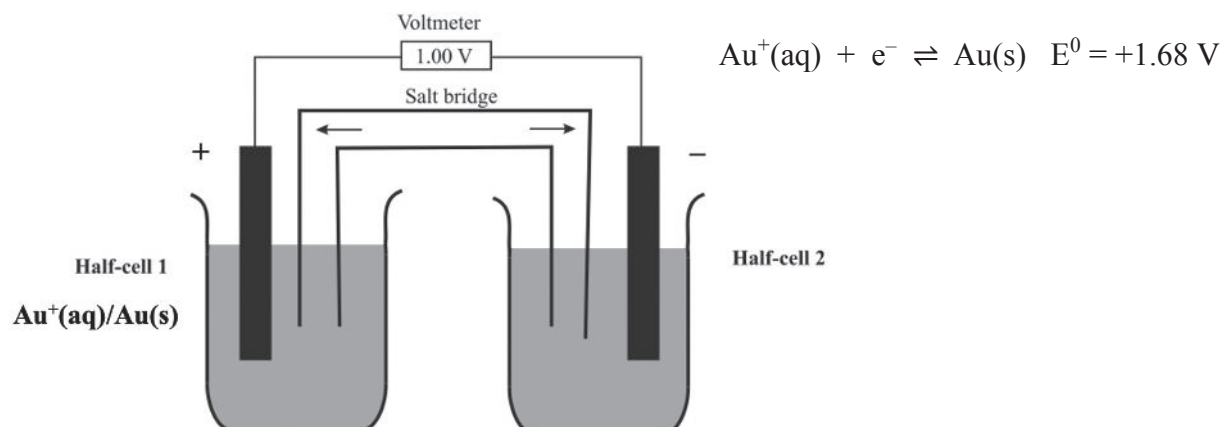

The product(s) of the half-equation occurring in Half-cell 2 is (are)

- A. $\text{O}_2(\text{g}) / \text{H}^+(\text{aq})$
- B. $\text{H}_2\text{O}_2(\text{aq})$
- C. $\text{Al}^{3+}(\text{aq})$
- D. $\text{Al}(\text{s})$

Question 9

A diagram of an alkaline primary cell is shown below.

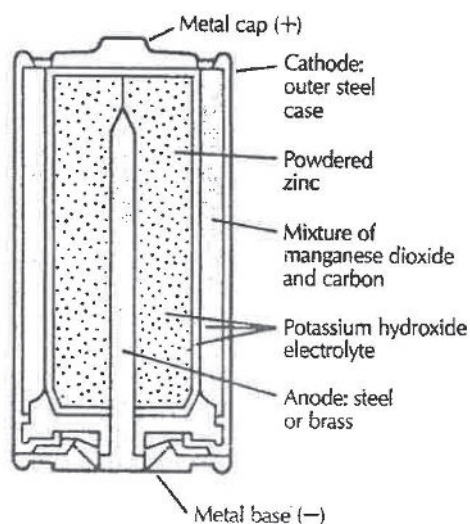

The overall equation occurring in this cell is

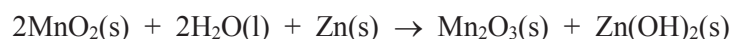

The main reaction occurring at the anode is

- A. $\text{Zn}(\text{s}) \rightarrow \text{Zn}^{2+}(\text{aq}) + 2\text{e}^-$
- B. $\text{Zn}(\text{s}) + 2\text{OH}^-(\text{aq}) \rightarrow \text{Zn}(\text{OH})_2(\text{s}) + 2\text{e}^-$
- C. $2\text{MnO}_2(\text{s}) + \text{H}_2\text{O}(\text{l}) + 2\text{e}^- \rightarrow \text{Mn}_2\text{O}_3(\text{s}) + 2\text{OH}^-(\text{aq})$
- D. $2\text{MnO}_2(\text{s}) + 2\text{H}^+(\text{aq}) + 2\text{e}^- \rightarrow \text{Mn}_2\text{O}_3(\text{s}) + \text{H}_2\text{O}(\text{l})$

Use the following information to answer Questions 10 and 11.

The diagram below is of a hydrogen-oxygen proton exchange membrane (PEM) fuel cell using an acidic electrolyte.

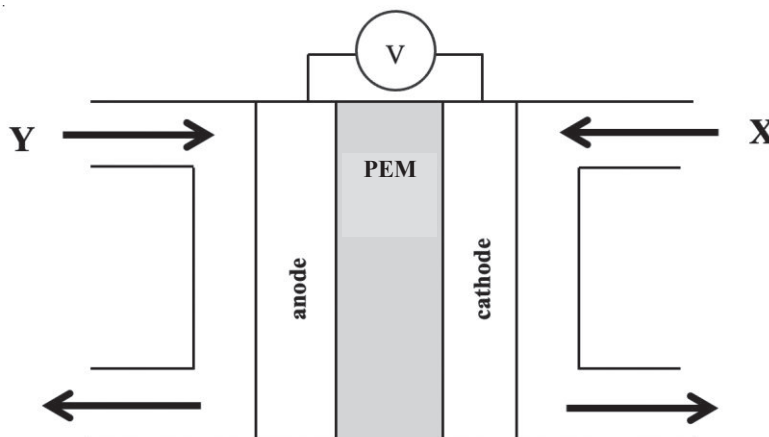

Question 10

Oxygen gas would enter at

- A. X and react at the positive electrode.
- B. X and react at the negative electrode.
- C. Y and react at the positive electrode.
- D. Y and react at the negative electrode.

Question 11

In the fuel cell, electrons move from

- A. the anode to the cathode and H^+ ions migrate towards the anode.
- B. the anode to the cathode and H^+ ions migrate towards the cathode.
- C. the cathode to the anode and H^+ ions migrate towards the anode.
- D. the cathode to the anode and H^+ ions migrate towards the cathode.

Question 12

Which of the following reactions will have the fastest initial rate?

- A. 10 g crushed $CaCO_3$ in 100 mL 1.0 M HCl at 25°C.
- B. 10 g crushed $CaCO_3$ in 100 mL 1.0 M HCl at 45°C.
- C. 10 g $CaCO_3$ chips in 100 mL 1.0 M HCl at 25°C.
- D. 10 g $CaCO_3$ chips in 100 mL 2.0 M HCl at 25°C.

Question 13

In a chemical reaction, a catalyst

- I increases the yield of the reaction.
- II increases the frequency of collisions.
- III increases the proportion of collisions that are successful.
- IV provides an alternative pathway with a lowered activation energy.

Which of the above statements are true?

- A. I, II, III and IV
- B. II, III and IV
- C. II and IV
- D. III and IV

Question 14

An important industrial process is the steam reforming of methane to produce hydrogen gas.

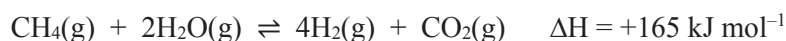

Which of the following sets of conditions would produce the greatest amount of hydrogen gas for a given amount of reactants (i.e. the highest yield)?

- A. 700 K and 300 kPa pressure
- B. 700 K and 100 kPa pressure
- C. 300 K and 300 kPa pressure
- D. 300 K and 100 kPa pressure

Question 15

A sealed container contains an equilibrium mixture of nitrogen, hydrogen and ammonia gases.

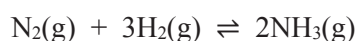

The volume of the container is then halved.

Which of the following correctly describes the concentrations of the gases at the new equilibrium compared to those at the original equilibrium?

	N₂	H₂	NH₃
A.	lower	lower	lower
B.	lower	lower	higher
C.	higher	lower	lower
D.	higher	higher	higher

Question 16

Consider the following equilibrium reaction.

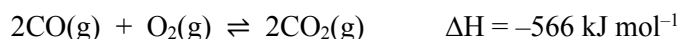

The temperature of an equilibrium mixture of the above chemicals is decreased and the amount of CO is changed by 0.15 mol.

Which of the following shows the changes that would occur?

	CO	O ₂	CO ₂
A.	decrease by 0.15 mol	decrease by 0.075 mol	increase by 0.15 mol
B.	decrease by 0.15 mol	decrease by 0.30 mol	increase by 0.15 mol
C.	increase by 0.15 mol	increase by 0.075 mol	decrease by 0.15 mol
D.	increase by 0.15 mol	increase by 0.30 mol	decrease by 0.15 mol

Question 17

Electrolysis of an aqueous solution of an ionic compound at standard conditions using inert electrodes is observed to produce a gas at both electrodes and a coating on neither electrode.

Which of the following compounds could it be?

- A. LiI(aq)
- B. CaCl₂(aq)
- C. NiSO₄(aq)
- D. ZnCl₂(aq)

Question 18

The following electrolytic cells (CELLS A–C) were connected in series using inert electrodes.

If one mol of electrons was passed through the circuit, in which cell would the greatest mass of product form on the cathode?

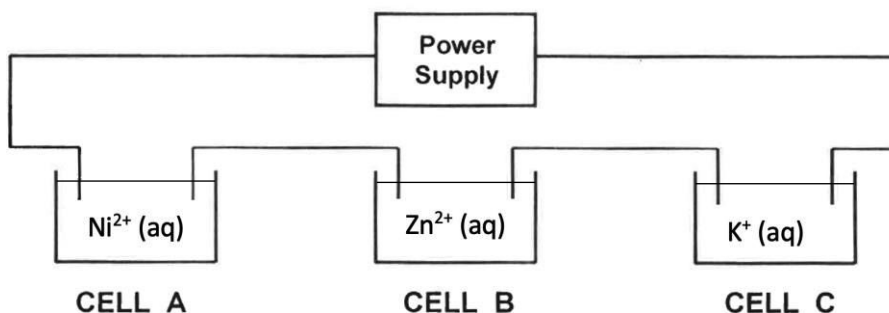

- A. CELL A
- B. CELL B
- C. CELL C
- D. The mass of products forming on the cathode in each cell will be the same as each cell receives one mol of electrons.

Question 19

Which one of the following electrolytic cells would produce the greatest number of moles of metal at the cathode?

- A. A current of 965 amps running for 1000 seconds through $\text{AlCl}_3(\text{aq})$.
- B. A current of 965 amps running for 100 seconds through $\text{CuCl}_2(\text{aq})$.
- C. A current of 965 amps running for 90 seconds through $\text{AgNO}_3(\text{aq})$.
- D. A current of 96.5 amps running for 1000 seconds through $\text{AlCl}_3(\text{l})$.

Question 20

Electrolysis is conducted on molten lithium, sodium and a third metal. The graph below shows the mass of each metal formed at the negative electrode as the amount of charge increases.

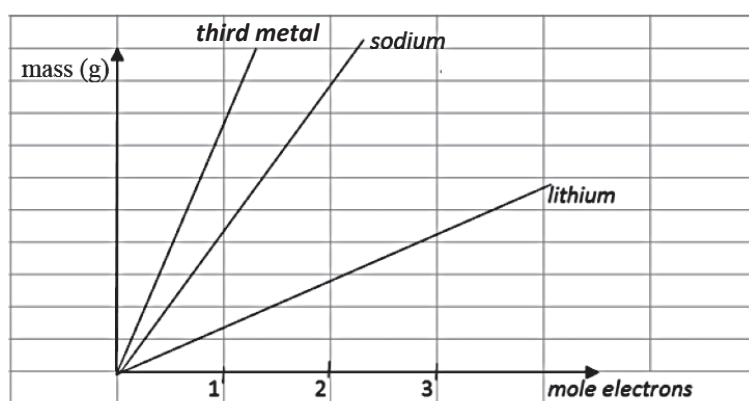

Which of the following metals could be the third metal?

- A. silver
- B. magnesium
- C. potassium
- D. calcium

END OF SECTION A

SECTION B (Total 65 marks)**Instructions for Section B**

Answer **all** questions in the spaces provided.

Give simplified answers to all numerical questions, with an appropriate number of significant figures; unsimplified answers will not be given full marks.

Show all working in your answers to numerical questions; no marks will be given for an incorrect answer unless it is accompanied by details of the working.

Ensure chemical equations are balanced and that the formulas for individual substances include an indication of state, for example, $\text{H}_2(\text{g})$, $\text{NaCl}(\text{s})$.

Unless otherwise indicated, the diagrams in this book are **not** drawn to scale.

Question 1

A group of friends go camping and use a Trangia™ stove to heat water. The fuel they use for the stove is called EkoFuel™. EkoFuel is pure bioethanol. Normally, Trangias use methylated spirits made from fossil fuels as the fuel.

wind shields with small holes for air entry

fuel burner – sits under the lower wind shield once the fuel is lit

- a. i. Bioethanol is produced by fermentation of glucose by yeast. Give a balanced chemical equation for this reaction.

1 mark

- ii. Explain why bioethanol is a more sustainable fuel than methylated spirits made from fossil fuels.

3 marks

- b. i.** 25.0 g of bioethanol is required to heat 1000 g of water from 21.0°C to 100.0°C.
Determine the molar heat of combustion of the bioethanol in the Trangia in kJ mol^{-1} .

3 marks

- ii.** Determine the percentage energy efficiency of the Trangia.

1 mark

- c.** Write a thermochemical equation for the complete combustion of ethanol if $\text{H}_2\text{O}(\text{g})$ is the product, not $\text{H}_2\text{O}(\text{l})$.



3 marks

The friends ate fruit bars as a snack. The information from the label of the fruit bars is shown below.

Serving size: 45 g

Nutrition	Average quantity per serving
Protein	4.5 g
Fat, total	7.4 g
- Saturated	1.0 g
Carbohydrate	24.8 g
- Sugars	6.1 g
Sodium	5 mg

- d. Calculate the energy content of the fruit bars in kJ / 100 g.

2 marks
Total 13 marks

Question 2

The following chemical equation is used to represent the reaction between permanganate ions and copper metal in an acidified aqueous solution.



Shown below is a simple galvanic cell that can be used to generate electricity via the above reaction at standard conditions.

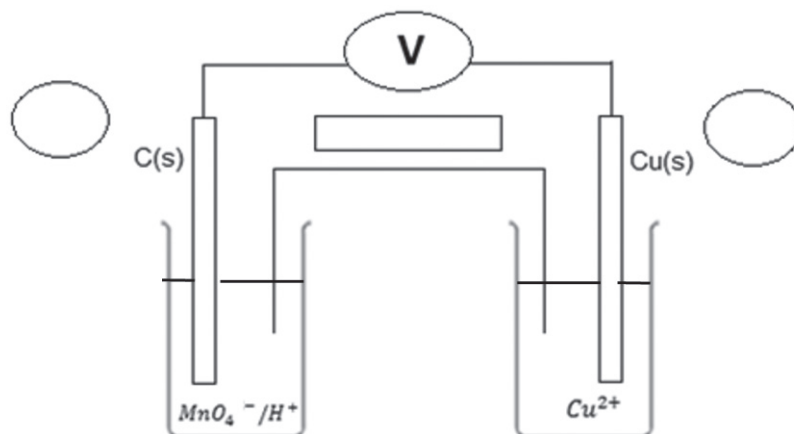

- a. *On the above diagram* in the two circles, **label** the polarity of each electrode.

1 mark

In the above galvanic cell, the salt bridge is soaked in a solution of potassium nitrate.

- b. *On the above diagram*, in the horizontal box, use an arrow to show the direction of the movement of the **cations** in the salt bridge.

1 mark

- c. Write a balanced half equation for the reaction that would occur at the cathode in the above galvanic cell.

1 mark

- d. State **two** changes that would be observed in this galvanic cell as the reaction proceeds.

2 marks

- e. The permanganate half-cell was replaced with a half-cell containing a nickel electrode in a 1 M solution of $\text{Ni}(\text{NO}_3)_2$.

- i. Calculated the expected cell potential difference of this revised galvanic cell.

1 mark

- ii. What chemical species would be the oxidant?

1 mark
Total 7 marks

Question 3

At a metropolitan sewage works, a biogas generator is built. The biogas is purified and passed through a methane-oxygen fuel cell. The fuel cell operates at 75°C in **alkaline** conditions. The products are carbon dioxide gas and water.

A simplified diagram of the fuel cell is shown below.

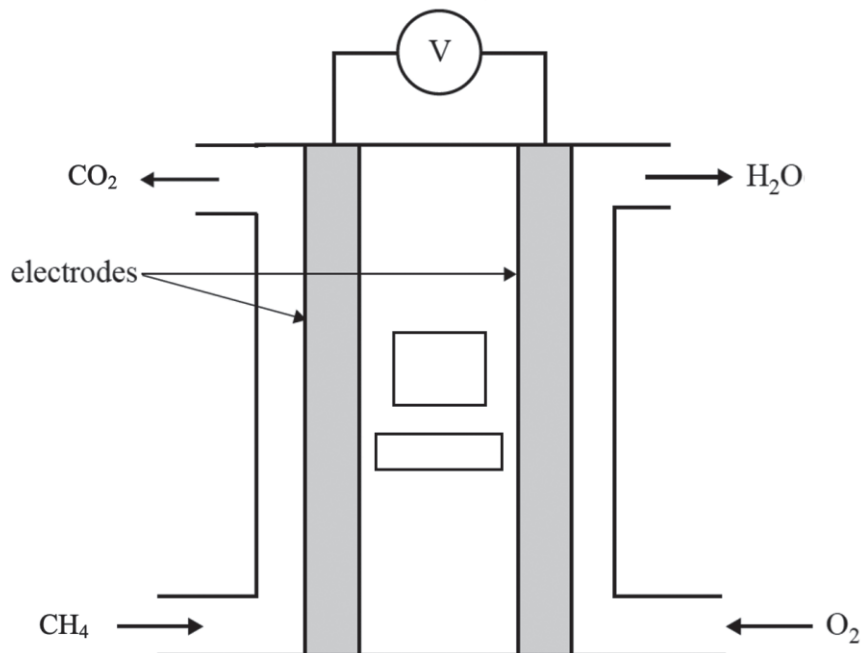

- a. Write the half-equation for the reaction that occurs at the anode of the fuel cell.

1 mark

- b. Write the half-equation for the reaction that occurs at the cathode of the fuel cell.

1 mark

- c. State the major energy transformation in the fuel cell.

1 mark

- d. In the two boxes *on the diagram of the fuel cell*, state the non-spectator electrolytic ion and use an arrow to show its direction when the cell is discharging.

2 marks

- e. The electrodes in the fuel cell are porous. State **two** functions of the electrodes.

2 marks

The methane-oxygen fuel cell runs at a potential difference of 1.0 V.

- f. Calculate the amount of energy, in MJ, that would be produced by 1.00 kg of methane in the fuel cell if it operated at 80% efficiency.

5 marks
Total 12 marks

Question 4

In two separate experiments, different samples of solid calcium carbonate were reacted with excess dilute hydrochloric acid. The gas produced was collected in a gas syringe. The graph of the results of the two experiments is shown below.

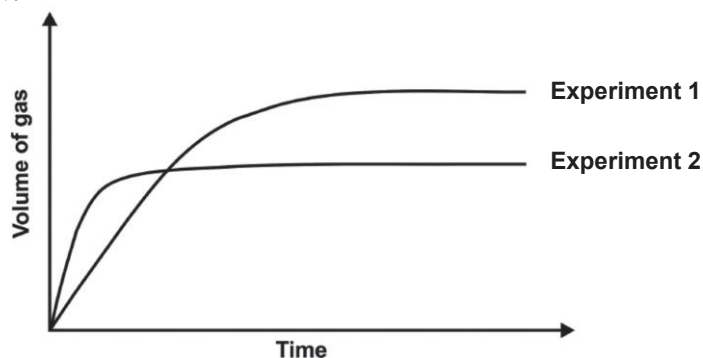

- a. Give the balanced chemical equation for this reaction.

1 mark

- b. State **two** possible changes to the calcium carbonate from Experiment 1 that would produce the results shown above for Experiment 2.

2 marks

- c. Using collision theory, explain how the changes in part **b.** result in a different **rate** of reaction in Experiment 2.

1 mark
Total 4 marks

Question 5

An experiment was conducted using the equilibrium system below to investigate aspects of Le Chatelier's Principle.

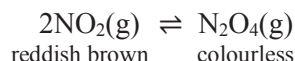

- a. Complete the following table that compares the **final equilibrium** after the stated change has been made with the **initial equilibrium**.

Change imposed	Observation	Equilibrium Shift (left or right)	Effect on K (higher, lower or no effect)	Effect on [NO ₂] (higher, lower or no effect)
Increase volume (at constant T)	lighter, then darker			
Cool (at constant V)	lighter			

2 marks

- b. Use Le Chatelier's Principle and the above observations to deduce the sign of ΔH for the above reaction. Explain your reasoning.

2 marks

- c. Write the expression for the equilibrium constant, K, for the above reaction.

1 mark

The value of K for this reaction at 298 K is 216 M⁻¹.

- d. If the concentration of N₂O₄ in an equilibrium mixture of the above gases at 298 K is 1.85 M, calculate the concentration of NO₂ in this mixture.

2 marks

- e. If a mixture of NO_2 and N_2O_4 in a 2.50 L container at 298 K contains 0.175 mol NO_2 and 0.320 mol N_2O_4 , explain why the mixture is not at equilibrium and state via which direction equilibrium would be achieved. Show all working and outline your reasoning.

3 marks

- f. Calculate the value of K for the following reaction at 298 K.

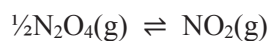

1 mark

Total 11 marks

Question 6

A practical investigation required a pair of students to observe the electrolysis of an aqueous solution of 1 M NiCl₂.

The students did two variations of the experiment: *Variation 1* and *Variation 2*.

The students used the same two types of electrodes for Variations 1 and 2: *Electrode A* and *Electrode B*.

Electrodes A and B are made of two different materials. 1 M NiCl₂ was used for both Variations.

Observations:*Variation 1*

- Bubbles of gas were produced at Electrode A. No odour associated with the gas was detected.
- A coating appeared on Electrode B.
- The Ni²⁺ concentration in the electrolyte decreased over time.

Variation 2

- No bubbles were detected at either electrode.
- A coating appeared on Electrode A.
- Electrode B appeared corroded and pitted.
- The Ni²⁺ concentration in the electrolyte remained constant over time.

a. For *Variation 1*:

- i.** Give the half-equation for the reaction occurring at Electrode A.

1 mark

- ii.** Give the half-equation for the reaction occurring at Electrode B.

1 mark

b. For *Variation 2*:

- i.** Give the half-equation for the reaction occurring at Electrode A.

1 mark

- ii.** Give the half-equation for the reaction occurring at Electrode B.

1 mark

c. Deduce what materials Electrodes A and B were made of.

i. Electrode A: _____

ii. Electrode B: _____

1 + 1 = 2 marks

d. What did the students do differently in Variations 1 and 2?

1 mark
Total 7 marks

Question 7

A Sydney company, Gelion, has produced a zinc-bromide battery plant in NSW. The rechargeable cells are used for energy storage for solar energy.

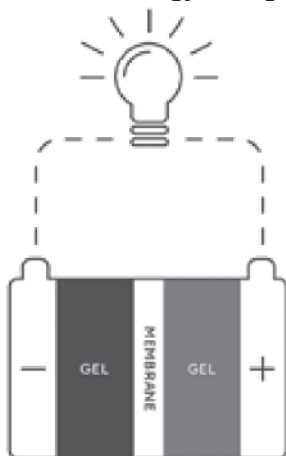

- The electrolyte is a gel that contains $\text{ZnBr}_2(\text{aq})$.
- Separating the two electrodes and gel reservoirs is a membrane.
- One electrode is made of zinc and the other electrode is made of carbon.
- The overall **discharge** reaction is:

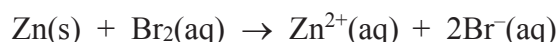

Source: https://gelion.com/wp-content/uploads/GEL008-Endure-Battery-Technology-Brochure_V2.pdf

a. Write the half-equations occurring at the anode and cathode during **recharge**.

i. anode _____

ii. cathode _____

1 + 1 = 2 marks

b. State the function of the membrane in this cell.

_____ 1 mark

c. State the material each electrode is made of.

i. positive electrode _____

ii. negative electrode _____

1 + 1 = 2 marks

d. Place ticks in **two** boxes in the following table next to the correct electrodes.

During discharge , the Zn^{2+} ions migrate to the:	positive electrode	negative electrode
During recharge , the Br^{-} ions migrate to the:	positive electrode	negative electrode

1 + 1 = 2 marks

The mass of zinc deposited at the electrode during recharge in one cell is 125 g. The discharge cycle runs at a current of 4.50 A.

e. Calculate the theoretical maximum amount of time, in hours, the discharge cycle can run for per cell before a recharge is necessary.

4 marks

Total 11 marks

END OF TRIAL EXAMINATION

