



THE SCHOOL FOR EXCELLENCE (TSFX)

VCE CHEMISTRY UNITS 3 & 4

WRITTEN EXAMINATION 2018

Reading Time: 15 minutes
Writing Time: 2 hours 30 minutes

QUESTION AND ANSWER BOOK

Student
Number:

Letter

Structure of Book

Section	Number of questions	Number of questions to be answered	Number of marks
A	30	30	30
B	10	10	90
			Total 120

- Students are permitted to bring into the examination room: pens, pencils, highlighters, erasers, sharpeners, rulers and one scientific calculator.
- Students are NOT permitted to bring into the examination room: blank sheets of paper and/or correction fluid/tape.

Materials Supplied

- Question and answer book of 39 pages.
- Data book
- Answer sheet for multiple choice questions.

Instructions

- Write your **student number** in the space provided above on this page.
- All written responses must be in English.

At the End of the Examination

Place the answer sheet for multiple-choice questions inside the front cover of this book.

Students are **NOT** permitted to bring mobile phones and/or any other unauthorised electronic devices into the examination room.

THIS PAGE IS BLANK

SECTION A – MULTIPLE CHOICE QUESTIONS

Instructions for Section A

Answer all questions in pencil on the answer sheet provided for multiple choice questions.

Choose the response that is **correct** or that **best answers** the question.

A correct answer scores 1, an incorrect answer scores 0.

Marks will **not** be deducted for incorrect answers.

No marks will be given if more than one answer is completed for any question.

Unless otherwise indicated, the diagrams in this book are **not** drawn to scale.

QUESTION 1

The standard half cell potentials for a rechargeable NICAD battery are shown below.

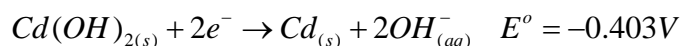

The reaction occurring at the anode when the battery is **recharging** is

- A. $Cd(OH)_{2(s)} + 2e^- \rightarrow Cd_{(s)} + 2OH_{(aq)}^-$
- B. $2NiO(OH)_{(s)} + H_2O_{(l)} + 2e^- \rightarrow 2Ni(OH)_{2(s)} + 2OH_{(aq)}^-$
- C. $Cd_{(s)} + 2OH_{(aq)}^- \rightarrow Cd(OH)_{2(s)} + 2e^-$
- D. $2NiO(OH)_{2(s)} + 2OH_{(aq)}^- \rightarrow 2NiO(OH)_{(s)} + H_2O_{(l)} + 2e^-$

QUESTION 2

An electrolytic cell consists of carbon electrodes and an electrolyte of silver nitrate. Which of the following observations can be expected to occur?

- A. Silver will form on the anode.
- B. The pH around the anode will be below 7.
- C. Bubbles will appear around the cathode.
- D. Water will undergo reduction.

QUESTION 3

A student had three beakers labelled A, B and C. Into each of the beakers he put a different solution and two carbon rods. The three solutions he used were silver chloride, copper (II) chloride and chromium (III) chloride.

After the solutions had been electrolysed for a short time, and some calculations were completed, the following graph was drawn.

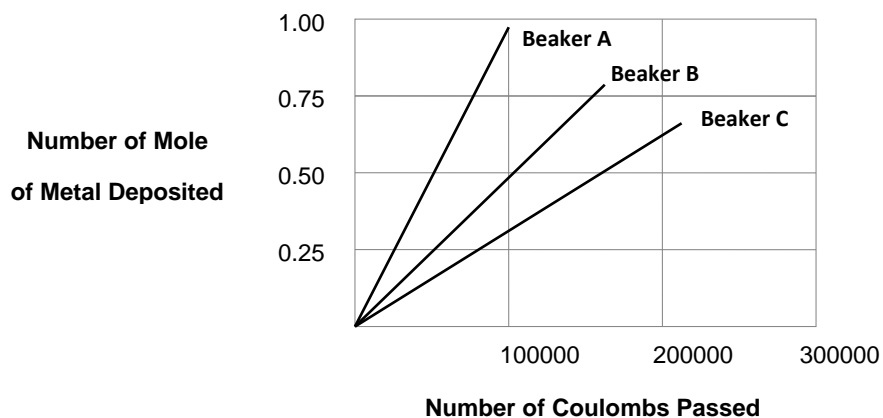

The solution in beaker C is

- A Silver chloride
- B Copper (II) chloride
- C Chromium (III) chloride
- D Cannot be determined

Use the following information to answer Questions 4 to 7.

A simple galvanic cell based on the reactants MnO_4^- / H^+ and Cu is shown in the diagram below.

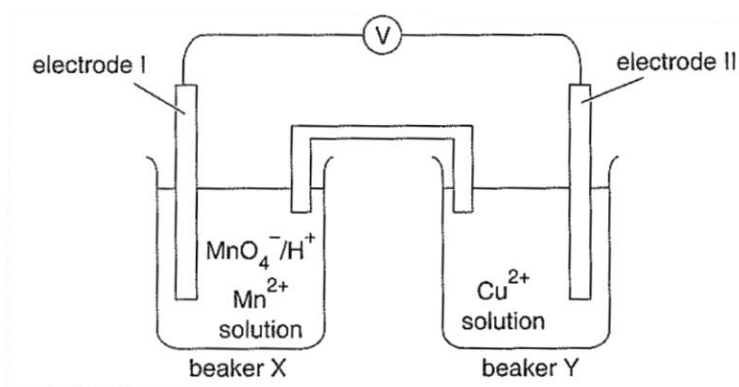

QUESTION 4

The overall balanced equation representing the reaction occurring in this cell when it is generating a current is

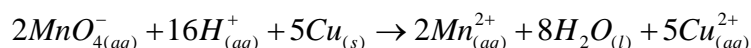

Which half reaction is occurring?

- A. Cathode: $\text{MnO}_4^- + 8\text{H}^+ + 6e^- \rightarrow \text{Mn}^{2+} + 4\text{H}_2\text{O}_{(l)}$
- B. Cathode: $\text{Cu}_{(s)} \rightarrow \text{Cu}_{(aq)}^{2+} + 2e^-$
- C. Anode: $\text{MnO}_4^- + 8\text{H}^+ + 6e^- \rightarrow \text{Mn}^{2+} + 4\text{H}_2\text{O}_{(l)}$
- D. Anode: $\text{Cu}_{(s)} \rightarrow \text{Cu}_{(aq)}^{2+} + 2e^-$

QUESTION 5

Which of the following correctly identifies electrodes I and II?

Electrode I	Electrode II
A. positive cathode	negative anode that loses mass
B. negative cathode that gains mass	positive anode
C. positive anode that loses mass	negative cathode
D. negative anode	positive cathode that gains mass

QUESTION 6

The most appropriate materials to use as electrodes I and II are

Electrode I	Electrode II
A. $\text{Mn}_{(s)}$	$\text{Cu}_{(s)}$
B. $\text{C}_{(s)}$	$\text{Cu}_{(s)}$
C. $\text{KMnO}_4_{(s)}$	$\text{Pt}_{(s)}$
D. $\text{Pt}_{(s)}$	$\text{C}_{(s)}$

QUESTION 7

When the cell is generating a current, which of the following correctly shows the direction of flow of electrons through the wire and of the cations and anions through the salt bridge?

Direction of flow of		
Electrons from Electrode	Cations from Beaker	Anions from Beaker
A. I to II	Y to X	X to Y
B. I to II	X to Y	Y to X
C. II to I	Y to X	X to Y
D. II to I	X to Y	Y to X

Use the following information to answer Questions 8 and 9.

The equation for a new equilibrium reaction is:

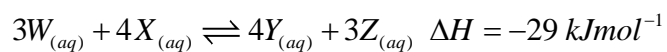

QUESTION 8

The unit for the equilibrium constant is:

- A. $\text{mol}^2\text{L}^{-2}$
- B. *No unit*
- C. molL^{-1}
- D. mol^{-1}L

QUESTION 9

The reaction mixture at equilibrium is diluted with an equal volume of de-ionised water. Compared with the original solution

- A. the concentration of X will increase.
- B. the concentration of W will decrease.
- C. the amount of Z will increase.
- D. the amount of Y will increase.

QUESTION 10

The concentration vs time graph of the following reaction is shown below:

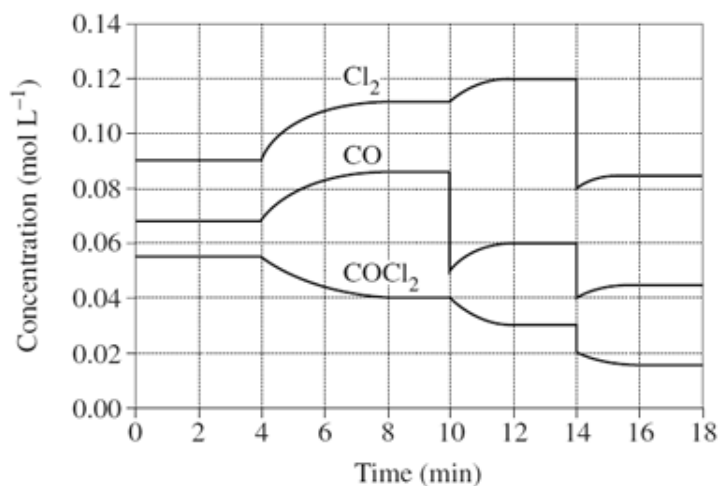
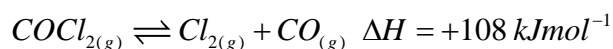

What are the changes that occurred at 4 minutes and 14 minutes?

4 minutes

- A. Decrease in Temperature
- B. Decrease in Temperature
- C. Increase in Temperature
- D. Increase in Temperature

14 minutes

- Increase in volume
- Decrease in volume
- Increase in volume
- Decrease in volume

Use the following information to answer Questions 11 and 12.

Solid calcium carbonate chips are reacted with hydrochloric acid to produce carbon dioxide, calcium chloride and water.

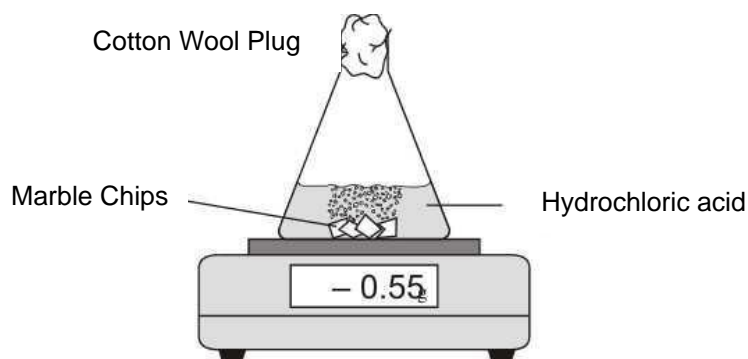
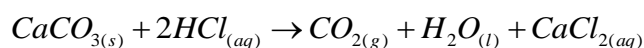

Time (min)	0	15	30	45	60	75	90
Mass Loss (g)	0	0.81	1.29	1.50	1.61	1.70	1.70

QUESTION 11

Consider the following statements:

- I There was no mass loss at time 0 minutes because the cotton wool prevented water from escaping.
- II The mass loss was due to HCl evaporating from the conical flask, as the reaction is exothermic.
- III At 75 minutes the reaction was complete.
- IV The fastest reaction rate occurred from 0 to 15 minutes when the concentration of the reactants are at its greatest values.
- V At 75 minutes the reaction had reached equilibrium.

Which statements are correct?

- A. I, III
- B. I, IV, V
- C. II, V
- D. III, IV

QUESTION 12

Which one of the following options will increase the rate of reaction?

- I Increase the surface area of the HCl solution
- II Increase the surface area of the calcium carbonate
- III Increase the pressure in the conical flask
- IV Remove carbon dioxide gas
- V Increase the concentration of HCl

- A. I, II
- B. I, III
- C. II, V
- D. II, IV

QUESTION 13

Biodiesel is produced by which one of the following reactions?

- A. Triglycerides undergo transesterification with potassium hydroxide to form biodiesel.
- B. Triglycerides are reacted with methanol to produce fatty acid methyl esters and biodiesel.
- C. Fats are reacted with methanol to produce glycerol and fatty acid methyl esters.
- D. Fats are reacted with potassium hydroxide and methanol to form fatty acid methyl esters.

QUESTION 14

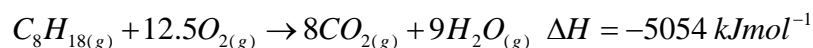

In the above reaction the total chemical energy of the products when compared with that of the reactants is

- A. Greater, as the bonds in the products are stronger and more stable.
- B. Lower, as the bonds in the products are stronger and more stable.
- C. Greater, as the bonds in the products are weaker and more stable.
- D. Lower, as the bonds in the products are weaker and less stable.

QUESTION 15

Some VCE students conducted an investigation on the energy produced during the incomplete combustion of propanol and ethanol.

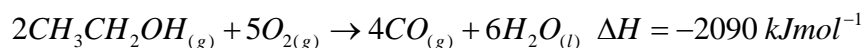
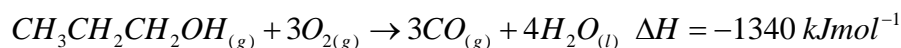

Separate experiments were conducted in which the same amount, in mole, of propanol and ethanol were used. In these experiments

- A. the combustion of ethanol produced more carbon monoxide.
- B. more heat energy was released from the combustion of propanol.
- C. both fuels produced the same amount of water.
- D. both fuels consumed the same amount of oxygen.

QUESTION 16

State the systematic name of the following compound.

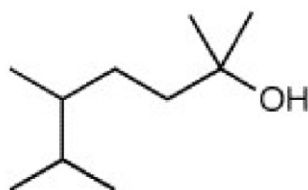

- A. 1,1,4,5-tetramethylhexan-1-ol
- B. 2,5,6-trimethylheptan-2-ol
- C. 4-propyl-1,1-dimethylpentan-1-ol
- D. 5-propyl-1,1-dimethylhexan-2-ol

QUESTION 17

The number of chiral centres in isoleucine is

- A. 1
- B. 2
- C. 3
- D. 4

QUESTION 18

Which of the following is not capable of existing as a pair of enantiomers?

A.

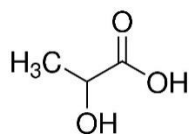

B.

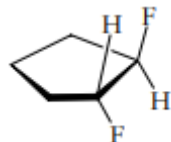

C.

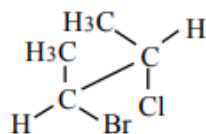

D.

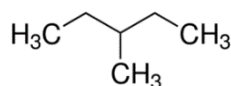
**QUESTION 19**

In the homologous series of amines, an increase in chain length from CH_3NH_2 to $CH_3(CH_2)_6CH_2NH_2$ is accompanied by

- | | Solubility in Hexane | Volatility |
|----|-----------------------------|-------------------|
| A. | Increased | Increased |
| B. | Increased | Decreased |
| C. | Decreased | Increased |
| D. | Decreased | Decreased |

QUESTION 20

As the electronegativity of a substituent increases in proton NMR spectroscopy, the shielding effect _____, and the chemical shift of adjacent (neighbouring) protons' signal _____.

- A. Increases Increases
- B. Increases Decreases
- C. Decreases Increases
- D. Decreases Decreases

QUESTION 21

The ^1H – NMR spectrum of a compound with formula $\text{C}_5\text{H}_{10}\text{O}_2$ is given below.

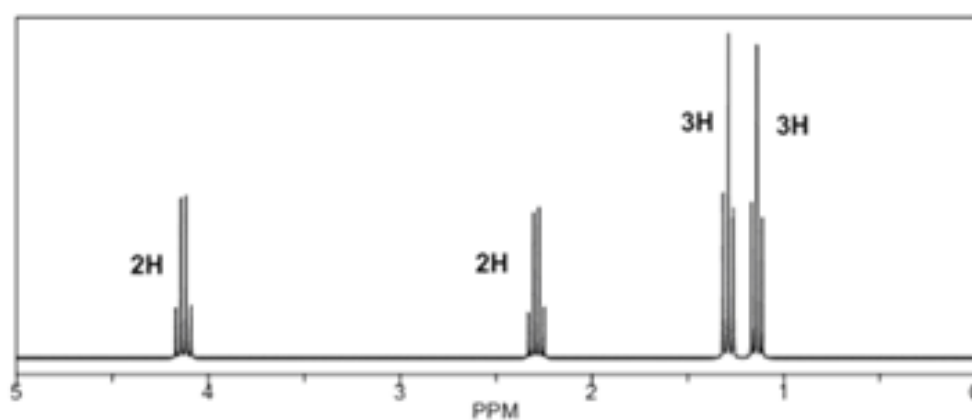

Which structure produced this spectrum?

A.

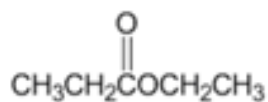

B.

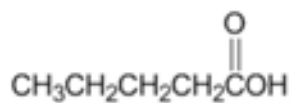

C.

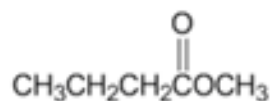

D. None of the above

QUESTION 22

Consider the infrared spectrum below.

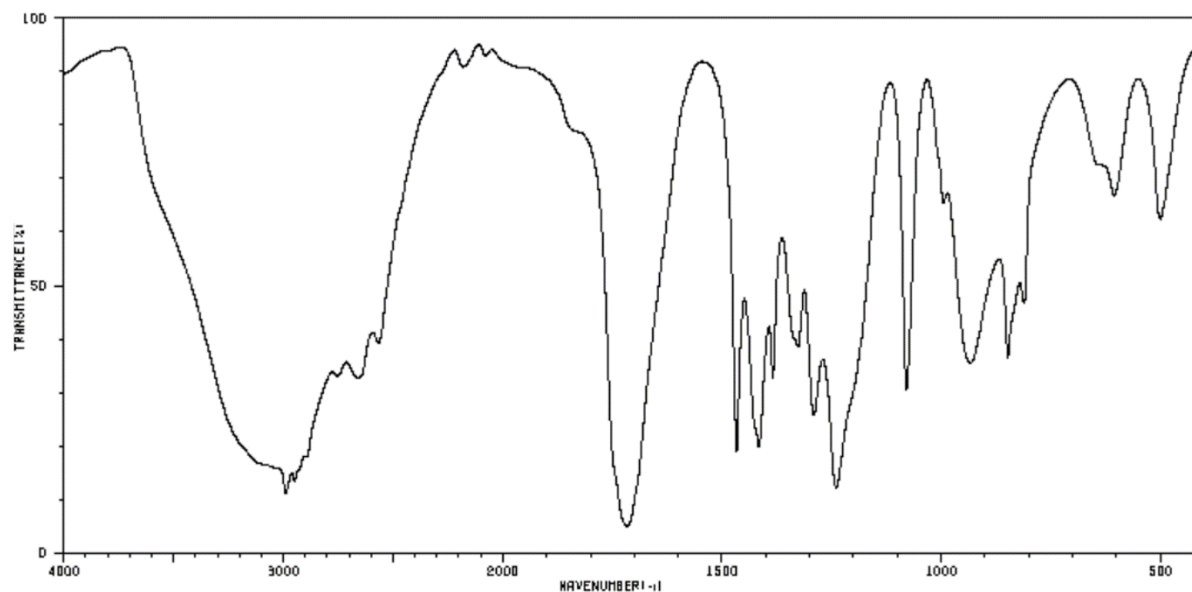

https://sdfs.db.aist.go.jp/sdfs/cgi-bin/direct_frame_top.cgi

The compound most likely to produce this spectrum is

- A. an alcohol
- B. a carboxylic acid
- C. an ester
- D. a ketone

QUESTION 23

Which of the following is capable of exhibiting cis-trans isomerism?

- A. ethene
- B. 1-butene
- C. 2-butene
- D. 1-pentene

QUESTION 24

Which of the following statements regarding Vitamin D is incorrect?

- A. Vitamin D does not readily react with acids or alkalis
- B. It is relatively resistant to oxidation
- C. It does not dissolve well in aqueous solutions
- D. It cannot be produced by humans and must therefore be supplied in the diet

QUESTION 25

The titration curve for the reaction of a base with an acid is shown below.

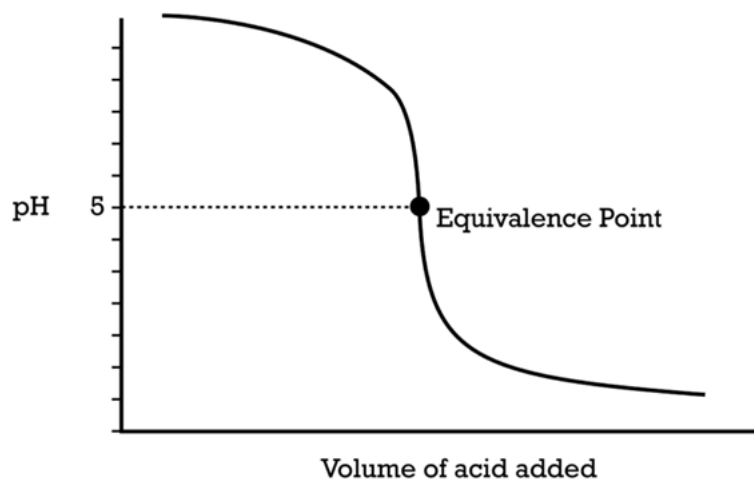

Which of the following statements regarding strength and indicator choice is correct?

	Acid Strength	Base Strength	Indicator to Use
A.	Strong	Weak	Methyl red
B.	Strong	Weak	Bromothymol blue
C.	Weak	Strong	Methyl red
D.	Weak	Strong	Bromothymol blue

QUESTION 26

Some carbohydrates convert Cu^{2+} ions to Cu^+ ions. This property is related to their ability to act as

- A. a reducing agent.
- B. an oxidising agent.
- C. an acid.
- D. a base.

QUESTION 27

The smallest product of the hydrolysis of sucrose is

- A. $C_6H_{12}O_6$
- B. H_2O
- C. CO_2
- D. $C_{12}H_{22}O_{11}$

QUESTION 28

Which of the following structures represents a natural amino acid?

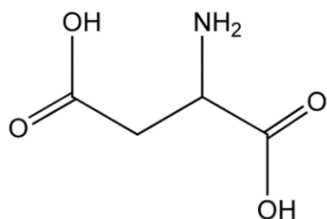
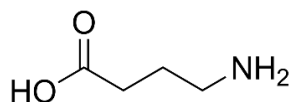
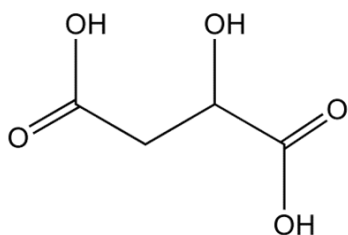
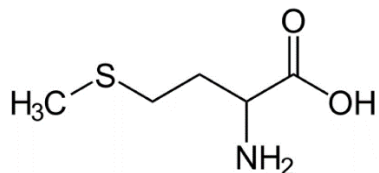
A.**B.****C.****D.****QUESTION 29**

Nervonic acid is an important fatty acid found in the brain, muscles and central nervous system. The molecular formula of nervonic acid is $C_{24}H_{46}O_2$. Nervonic acid is therefore classified as

- A. A saturated fatty acid
- B. A monounsaturated fatty acid
- C. A polyunsaturated fatty acid
- D. An omega-3 fatty acid

QUESTION 30

The induced fit model is best described as the process by which

- A. a substrate adopts the correct 3-dimensional shape before it enters the active site.
- B. a substrate binds to an active site whose geometric shape is complementary to the geometric shape of the substrate molecule.
- C. a substrate binds to the active site of an enzyme and the active site molds itself to the shape of the molecule.
- D. an active site alters the shape of the substrate such that it adopts the correct 3-dimensional shape required for binding.

SECTION B

Instructions for Section B

Answer **all** questions in the spaces provided. Write using black or blue pen.

Give simplified answers to all numerical questions, with an appropriate number of significant figures; unsimplified answers will not be given full marks.

Show all working in your answers to numerical questions; no marks will be given for an incorrect answer unless it is accompanied by details of the working.

Ensure chemical equations are balanced and that the formulas for individual substances include an indication of state, for example, $H_{2(g)}$, $NaCl_{(s)}$.

Unless otherwise indicated, the diagrams in this book are not drawn to scale.

QUESTION 1 (10 marks)

The complete combustion of ethanol in oxygen is given by the equation below.

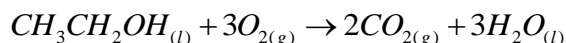

- a. Draw the energy profile of the combustion of ethanol given that the activation energy (E_a) of the forward reaction is 55 kJmol^{-1} and the enthalpy of the reactants is 1370 kJmol^{-1} . On your diagram, show the enthalpy of the reactants ($H_{\text{Reactants}}$) and products (H_{Products}), ΔH and E_a .

2 marks

Enthalpy (kJ/mol)

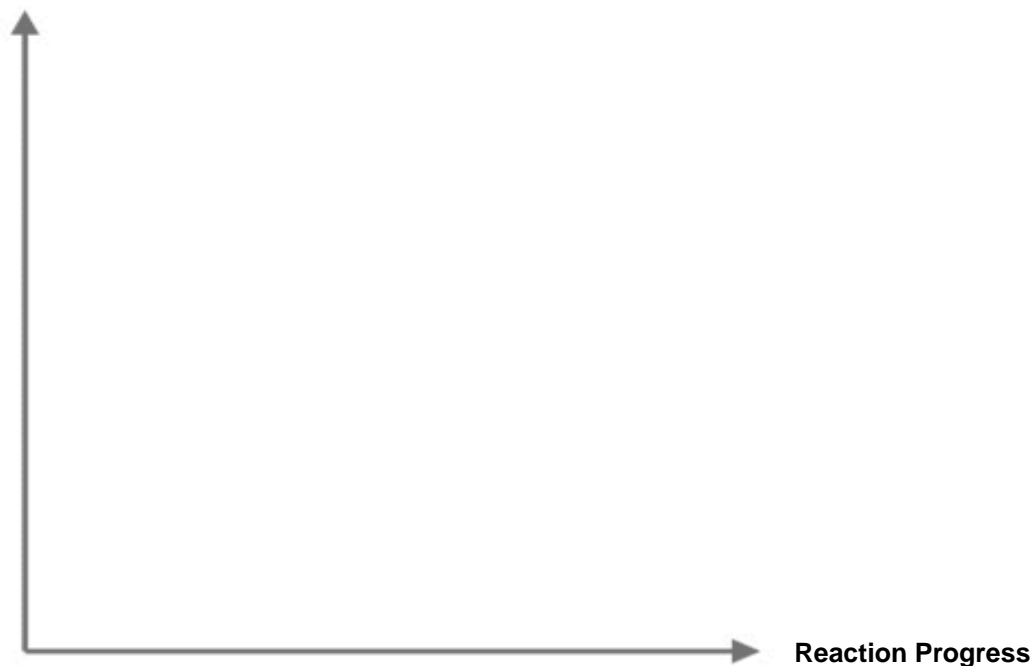

- b. (i)** Calculate the mass of ethanol required to boil 5.00 L of icy water (0.00°C , density 0.9167 g/ml) at an altitude of $1,849\text{ m}$, where the boiling point of water is 93.89°C . 3 marks

- (ii)** What volume of CO_2 would be produced at 5.00°C and 100 kPa if $5.2 \times 10^3\text{ kJ}$ of energy is released when ethanol is combusted in excess oxygen? 2 marks

c. One disadvantage of using ethanol as a fuel is that it is more hygroscopic than octane.

(i) Why is ethanol more hygroscopic than octane? 2 marks

(ii) Why does the presence of water lower the energy content of ethanol? 1 mark

QUESTION 2 (7 marks)

Two electrolytic cells are connected in series as shown below. A current of 5.00 A flows for 10.0 minutes.

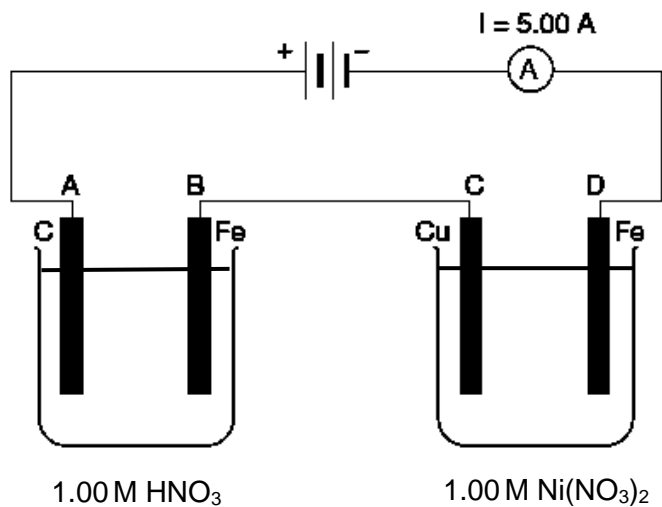

- a. Write the half equations for the reactions occurring at 2 marks

Electrode A:

Electrode D:

- b. Calculate the charge flowing through each cell. 1 mark

- c. Calculate the change in mass of electrode D after 10.0 minutes 2 marks

d. Calculate the volume of gas formed at electrode A after 10.0 minutes at SLC. 2 marks

QUESTION 3 (6 marks)

Consider the galvanic cell formed by the combination of the two half-cells $Pb_{(aq)}^{2+} / Pb_{(s)}$ and $Cu_{(aq)}^{2+} / Cu_{(s)}$.

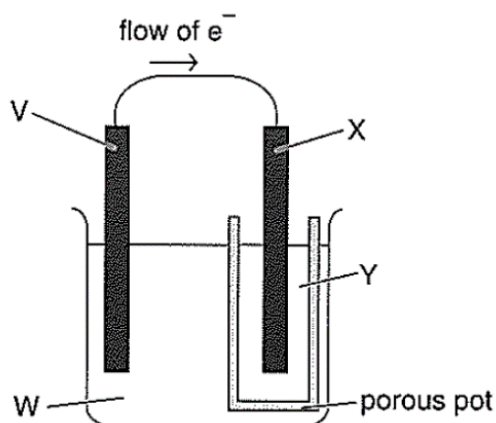

- a. Using names from the list below, state what V, W, X and Y are in order to cause the electron flow shown in the diagram. 2 marks

lead, copper, copper (II) nitrate solution, lead (II) nitrate solution

V is _____

W is _____

X is _____

Y is _____

- b. Predict the approximate voltage (emf) at standard conditions. 1 mark

- c. Explain in terms of chemical reactions and electron flow, what would happen if the porous pot was removed, allowing solutions W and Y to mix. 2 marks

- d. The $Pb_{(aq)}^{2+} / Pb_{(s)}$ and $Cu_{(aq)}^{2+} / Cu_{(s)}$ galvanic cell was constructed in a slightly different way, as shown below.

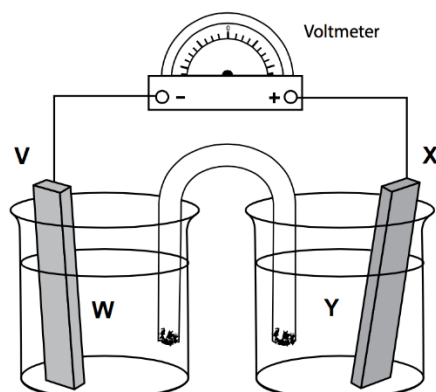

The solutions are connected to each other with a salt bridge consisting of an inverted U-tube containing an appropriate electrolyte.

Circle the species from the list below that could be used as the electrolyte for the salt bridge in the illustrated cell.

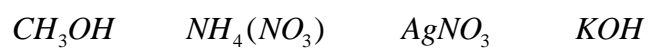

QUESTION 4 (7 marks)

Finely ground platinum (Pt) was added to the hydrogenation reaction of 1-hexene.

- a. It was observed that the reaction occurred much faster than when the platinum was coarsely ground. However, the enthalpy change for the reaction remained the same. Give a reason for this observation. 2 marks

The diagram below shows the distribution of energy in a sample of gases, at a particular temperature. E_a represents the activation energy of the reaction between 1-hexene and hydrogen gas and T_1 is a lower temperature than T_2 .

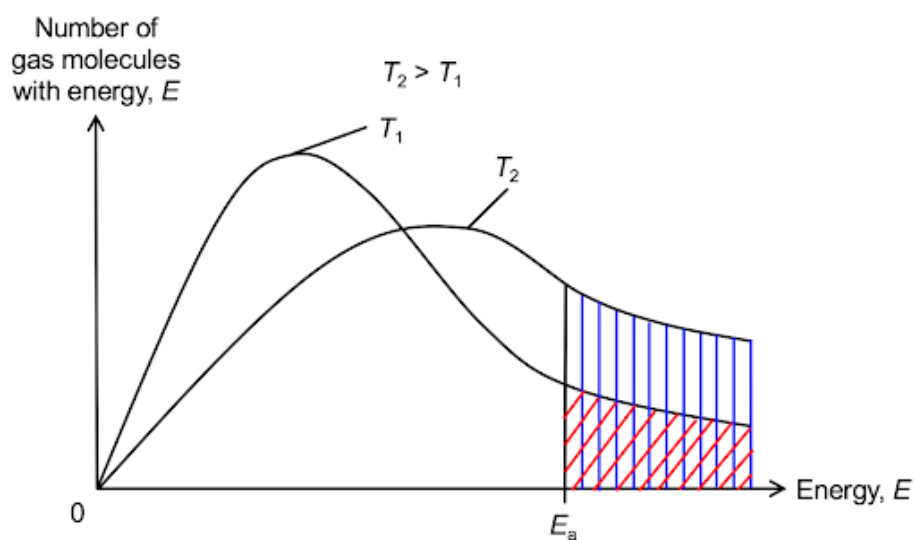

- b. (i) What is the activation energy and its role in a chemical reaction? 1 mark

- (ii) Explain the significance of the difference in shape of T_1 compared to T_2 and the difference in the area shaded under the respective curves. 2 marks

- (iii) If a catalyst is introduced, indicate on the graph, the change, if any, that will occur. Explain the effect that the catalyst has on the reaction. 2 marks

QUESTION 5 (10 marks)

Methanol is an important industrial chemical used in the manufacture of many chemicals. It is produced by the reaction of carbon monoxide and hydrogen gas as shown below.

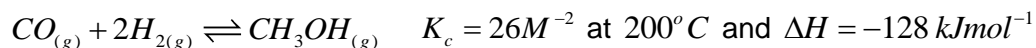

- a. (i) Write the expression for the Equilibrium Constant for this reaction. 1 mark

- (ii) 51.5 mole of carbon monoxide and 153 mole of hydrogen are present in a 200 L tank at equilibrium. Calculate the concentration of methanol in the equilibrium mixture. 2 marks

- b. Several changes were made to the methanol equilibrium system.

Complete the table below stating: **INCREASES/DECREASES/STAYS THE SAME** to indicate the effect of these changes on the yield of methanol and the Equilibrium Constant. 4 marks

Changes	Yield of Methanol (mole)	Equilibrium Constant
Add $CO_{(g)}$		
Remove $H_{2(g)}$		
Increase Pressure		
Increase Temperature		

Methanol offers several advantages as a fuel. It is inexpensive, has a relatively high energy density and can be easily transported and stored.

Consider a direct methanol fuel cell with a liquid methanol and water solution in the anode and an air cathode.

- c. (i) State one way that a fuel cell differs from a galvanic cell. 1 mark

- (ii) Write a balanced half-equation for the cathode reaction. 1 mark

- (iii) The overall equation for the reaction that occurs in the methanol fuel cell is

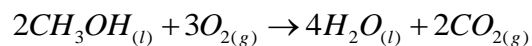

- State the half-equation for the anode reaction. 1 mark

QUESTION 6 (12 marks)

Below is a diagram of a bomb calorimeter which can be used to determine the enthalpy changes in combustion reactions.

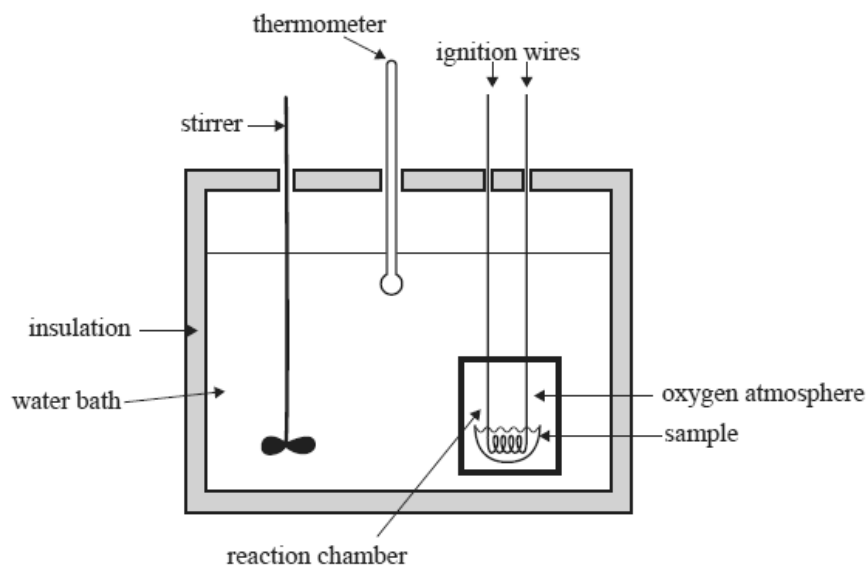

Benzoic acid is often used as a reference material for bomb calorimetry because it burns completely in oxygen, is stable, and is readily available in very pure form.

1.890 g of pure solid benzoic acid (C_6H_5COOH) is placed in a bomb calorimeter. 800 seconds later, pure oxygen is pumped into the bomb to a pressure of 25 atm and the benzoic acid is ignited via the passage of a current through the ignition wires.

The following temperature vs time graph was obtained.

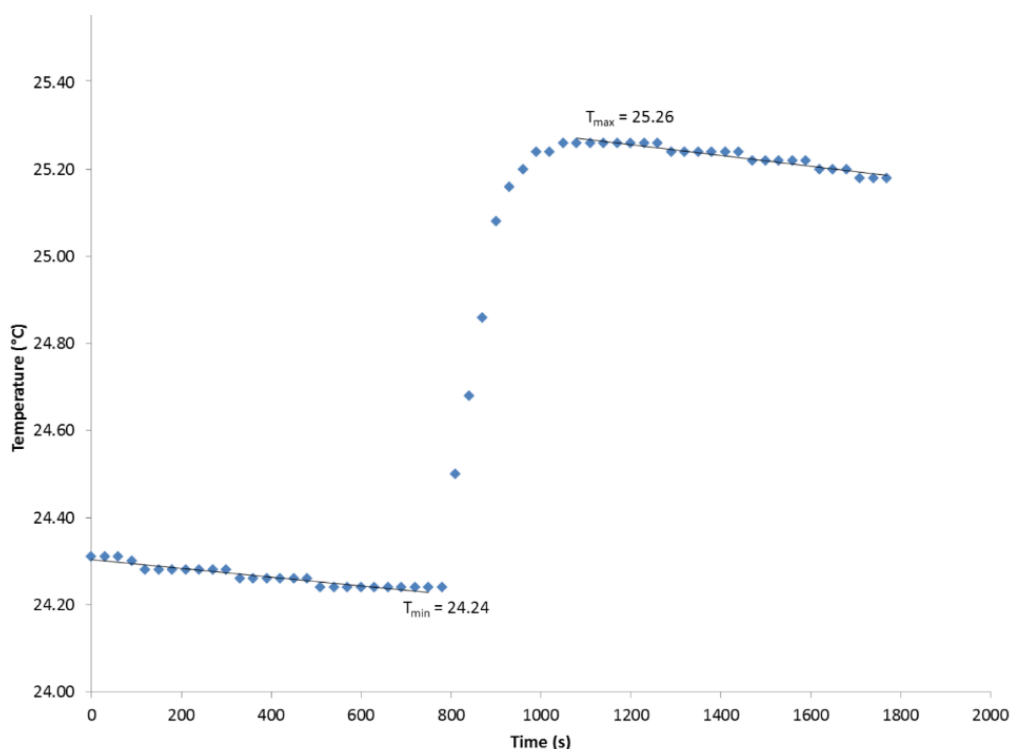

<https://www.csuci.edu/writing-ci/guide/samples/documents/chem-lab-sample.pdf>

- a. (i) Why must the oxygen be pumped into the bomb at high pressure? 1 mark

- (ii) Why does the temperature of the calorimeter decrease before and after the combustion of benzoic acid? 1 mark

The molar heat of combustion for benzoic acid is known to be 3227 kJmol^{-1} .

- b. (i) Write a thermochemical equation for the complete combustion of benzoic acid. 2 marks

- (ii) Calculate the calibration factor of the calorimeter in kJK^{-1} . 3 marks

- (iii) What change (if any) would be observed in the value of the calibration factor if the volume of water in the calorimeter was halved? Give a reason for your answer.

2 marks

After calibrating the calorimeter, a 2.00 g sample of sucrose was combusted in the same calorimeter and the following temperature vs time graph was obtained.

Sucrose vs Time

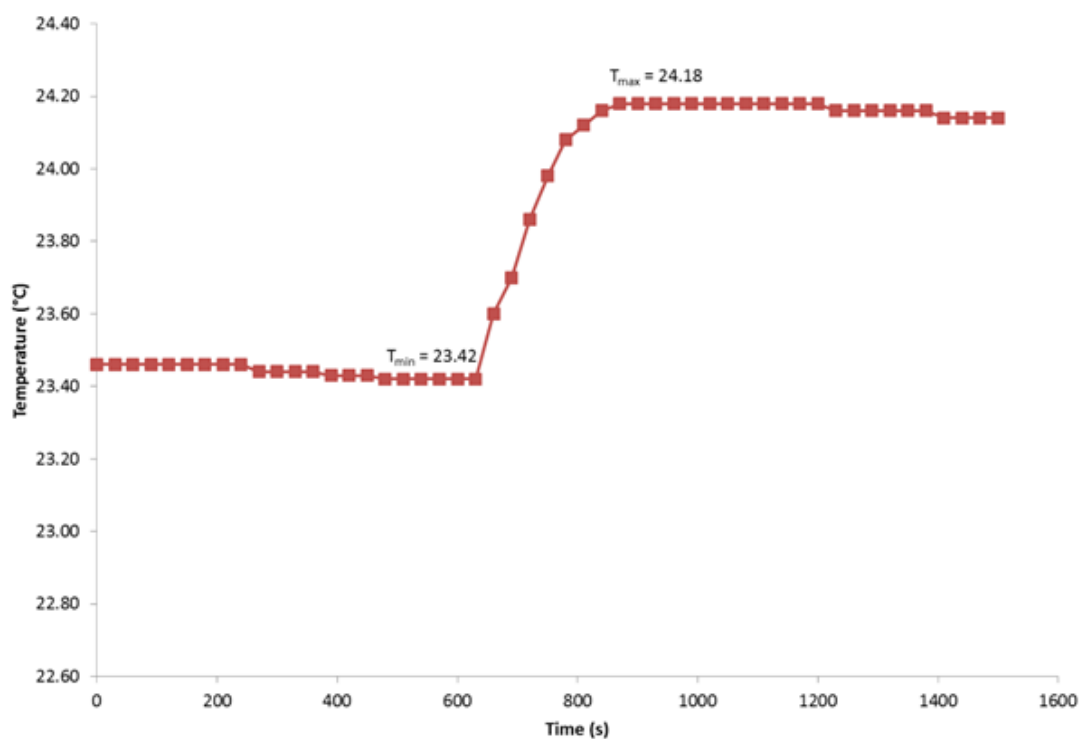

<https://www.csuci.edu/writing-ci/guide/samples/documents/chem-lab-sample.pdf>

c. Calculate the molar enthalpy of the combustion of sucrose, $C_{12}H_{22}O_{11}$. 3 marks

QUESTION 7 (8 marks)

Consider the following reaction sequences.

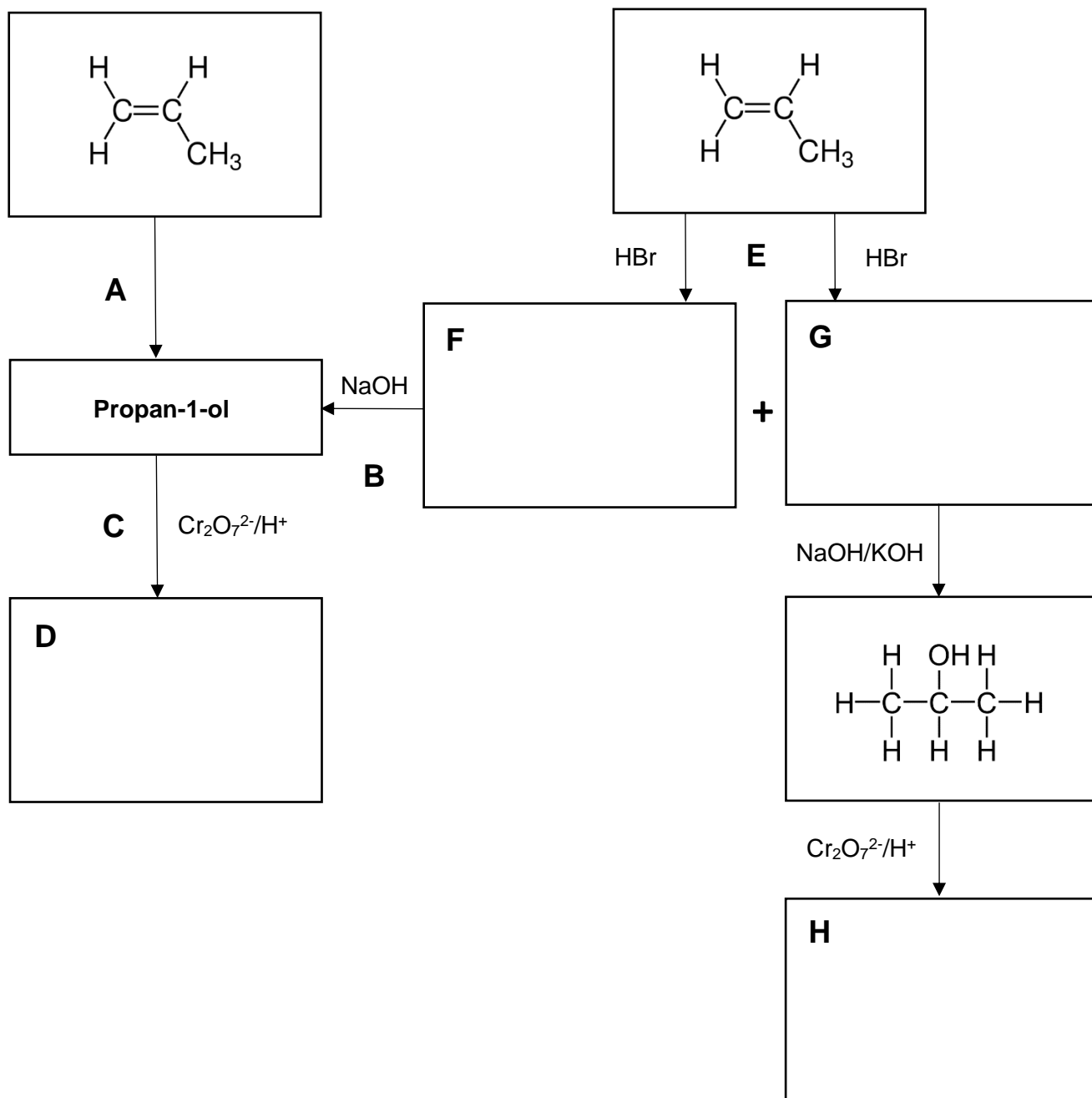

- a. State the reagents and reaction conditions required at Point A. 1 mark

- b. In the boxes provided, draw structural formulae for the species at D, F, G and H. 4 marks

c. Calculate the atom economy in the production of propan-1-ol from molecule F.

2 marks

d. Circle the option that correctly describes the types of reactions occurring at A, B, C and E.

1 mark

	A	B	C	E
Option 1	Addition	Addition	Reduction	Halogenation
Option 2	Addition	Hydrolysis	Oxidation	Substitution
Option 3	Hydration	Substitution	Oxidation	Addition
Option 4	Hydration	Hydration	Oxidation	Substitution

QUESTION 8 (11 marks)

The structure of a portion of an enzyme, with some of its constituent atoms shown, is given below.

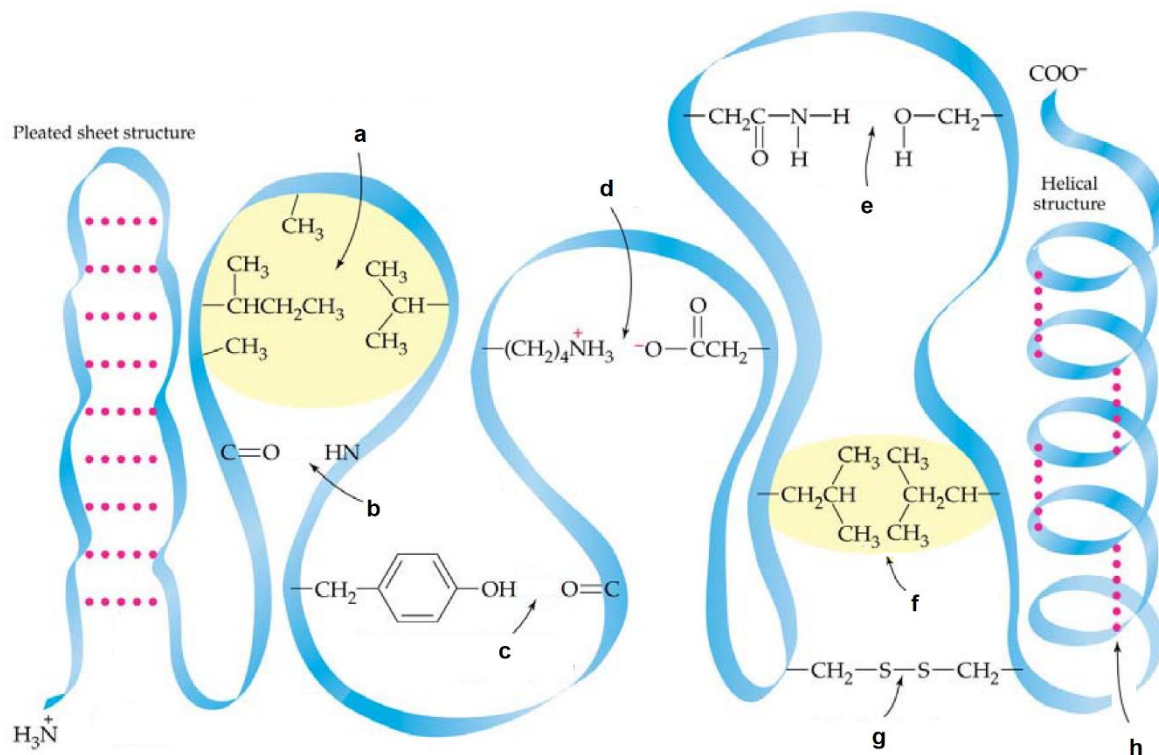

<http://www.chem.latech.edu/~upali/chem121/Protein%20POGIL.pdf>

a. (i) Identify the interactions occurring at a. 1 mark

(ii) Which bonds will be disrupted when alcohol is added to the enzyme solution?
Circle every correct option.

a b c d e f g h 1 mark

(iii) State the bonding that will arise at d. 1 mark

The activity of the enzyme at different temperatures is shown in the diagram below.

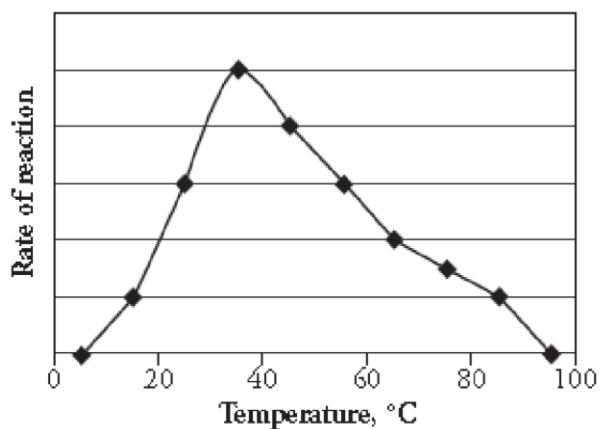

b. (i) Why does the reaction rate increase between 0 and 38°C? 2 marks

(ii) Why does the rate of reaction decrease between 38 and 100°C? 2 marks

Insulin is a large polypeptide molecule with a molar mass of 5808 g mol^{-1} . It consists of an A chain and a B chain that are connected together by two disulfide bridges, as shown below.

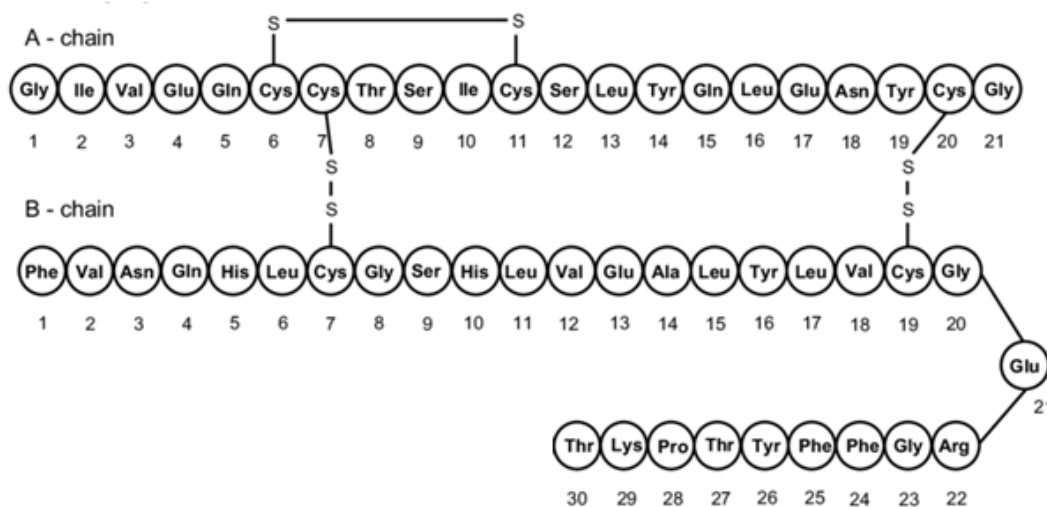

<http://contemporarymedicine.net/the-physiology-and-clinical-pharmacology-of-insulin-in-its-application-in-insulin-potential-therapy/>

- c. Aspartic acid and threonine can combine together to form two different dipeptides. Draw the structural formula of one of these two dipeptides as it would exist in a solution at pH 3.

2 marks

- d. What is the molar mass of the individual amino acids that make up the protein?

2 marks

QUESTION 9 (10 marks)

Vitamin C or ascorbic acid is a water-soluble compound that is essential for life. Although it's involved in many processes in the human body, humans do not have the ability to make their own vitamin C, and must therefore obtain it through their diet or through vitamin supplements.

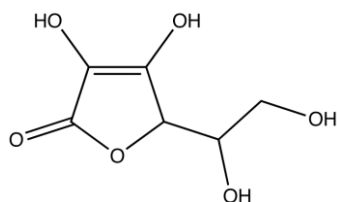

Ascorbic acid

Two Vitamin C ($C_6H_8O_6$) tablets were crushed and then dissolved to make 250.00 cm^3 of solution using deionised water. 25.00 cm^3 of this solution was pipetted into a conical flask along with a few drops of starch. 0.0150 M iodine solution was delivered from a burette until the blue/black colour just remained. The volume of iodine used was noted, and the procedure was repeated until 3 concordant results were obtained. The average titre was 11.60 cm^3 .

- a. As the iodine is added during the titration, the ascorbic acid is oxidised to dehydroascorbic acid ($C_6H_6O_6$), while the iodine is reduced to iodide ions.

(i) Write equations for the oxidation and reduction half reactions. 2 marks

(ii) Hence write the overall reaction that occurs between Vitamin C and iodine. 1 mark

- b. (i) Calculate the amount, in mol, of ascorbic acid in the 25.00 cm^3 aliquot. 1 mark

(ii) The molar mass of ascorbic acid is 176.14 g mol^{-1} . Calculate the mass of ascorbic acid in the 25.00 cm^3 aliquot. 1 mark

- (iii) If a tablet weighs 700 mg , calculate the percentage by mass of Vitamin C in a tablet. 2 marks

- (iv) While preparing the Vitamin solution, you accidentally forget to dilute the solution to the mark. What effect would this have on the calculated percentage by mass? 1 mark

- c. (i) Explain, with reference to bonding, why Vitamin C is soluble in water. 1 mark

- (ii) Ascorbic acid and its esters function as antioxidants with some substrates. Circle the part of the molecule on the omega-3 fatty acid chain in the compound below that is protected by the action of Vitamin C. 1 mark



QUESTION 10 (10 marks)

Figure 1 shows a chromatogram of a standard mixture of 9 fatty acids that were separated using high pressure liquid chromatography (HPLC).

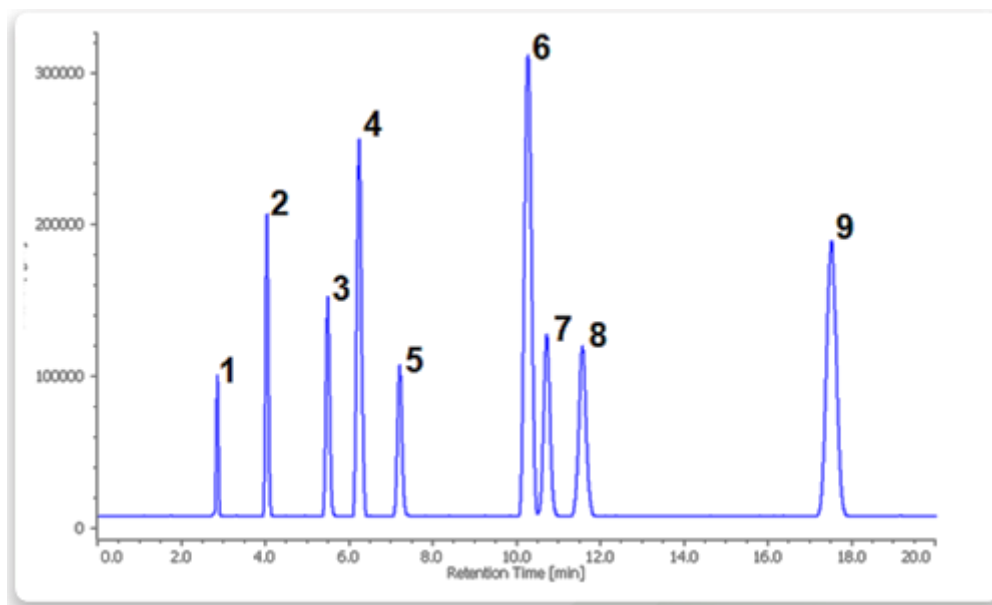

- 1: Capric acid (C10)
- 2: Lauric acid (C12)
- 3: Linolenic acid (C18)
- 4: Myristic acid (C14)
- 5: Linoleic acid (C18)
- 6: Palmitic acid (C16)
- 7: Oleic acid (C18)
- 8: Elaidic acid (C19)
- 9: Stearic acid (C18)

a. (i) Is the stationary phase used for this separation polar or non-polar? Give a reason for your answer. 2 marks

(ii) Which fatty acid would produce biodiesel with the lowest cloud point? Give a reason for your answer. 2 marks

The chromatogram of rice bran oil which was processed under identical conditions and using the same column is shown below.

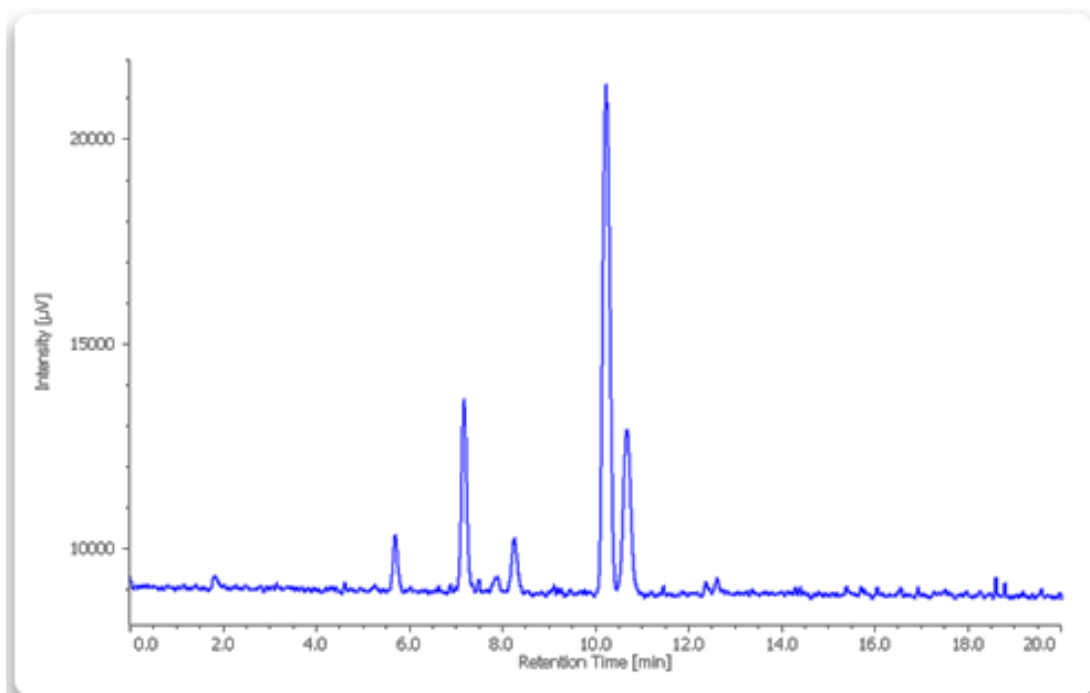

- b. Identify the fatty acid present in the highest concentration in rice bran oil. 1 mark

Elaidic acid is not found in natural vegetable oil. It is produced during the manufacturing process of hydrogenated oils such as margarine.

- c. A sample of rice bran oil was reacted with excess hydrogen gas in the presence of nickel catalyst at 150°C . Would you expect the HPLC retention time of the hydrogenated product(s) to increase, decrease or remain the same? Give a reason for your answer.

2 marks

The chromatogram of margarine is given below.

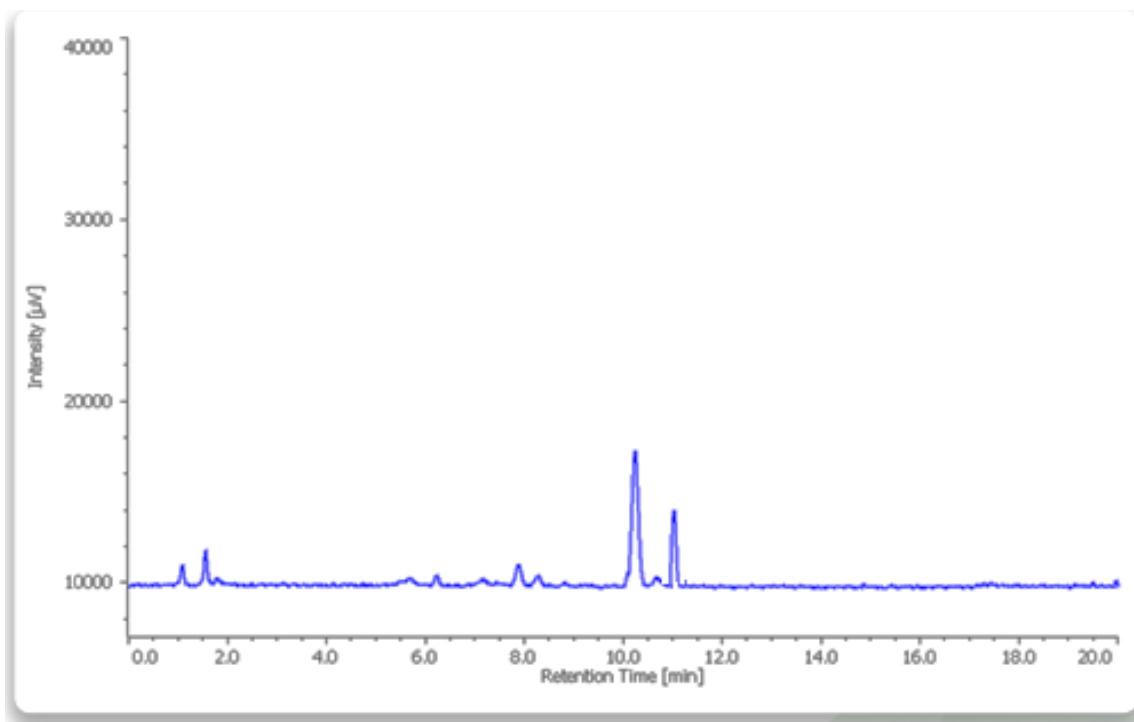

Elaidic acid was added to a sample of the margarine and the following chromatogram was obtained.

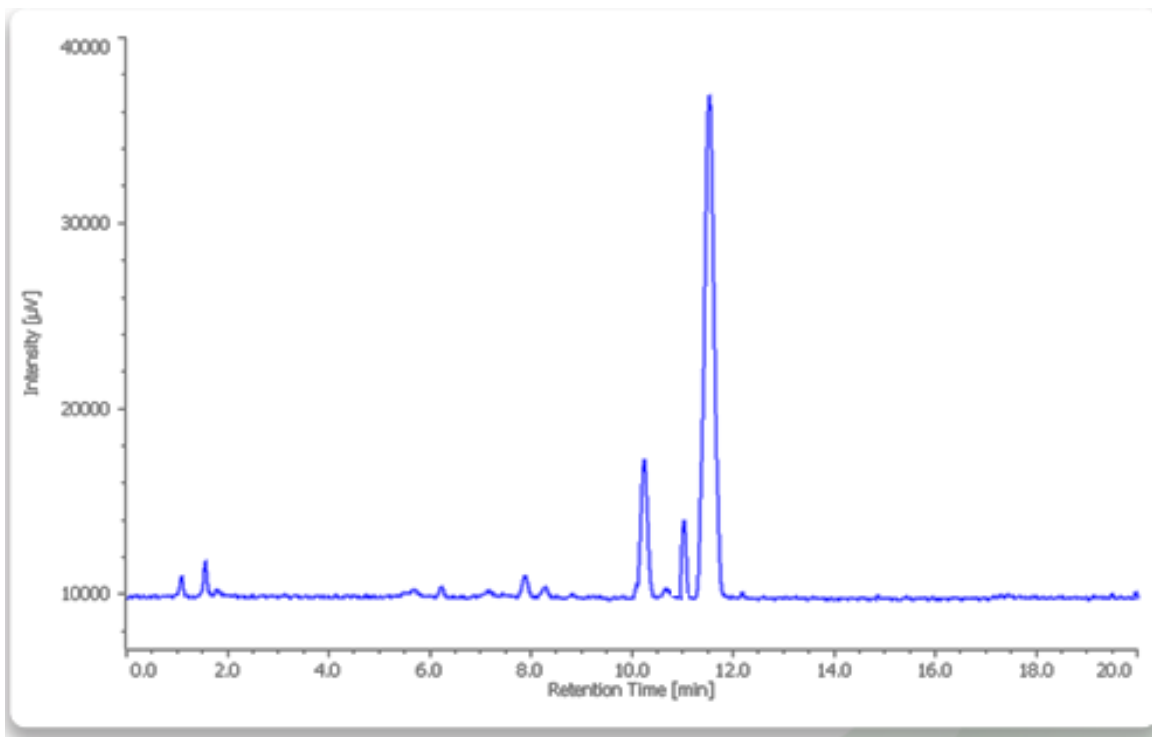

- d. Explain how the chromatogram indicates that the margarine has no elaidic acid present. 1 mark

Depending on the source, rice bran oil contains varying amounts of linolenic acid. To determine the concentration of linolenic acid in the rice bran oil, 1.00 cm^3 of different concentrations of pure linolenic acid were dissolved in acetone to make 20.00 cm^3 of solution, and passed through the HPLC column under the same conditions as that used for rice bran oil. The peak areas were determined, and the following calibration curve was obtained.

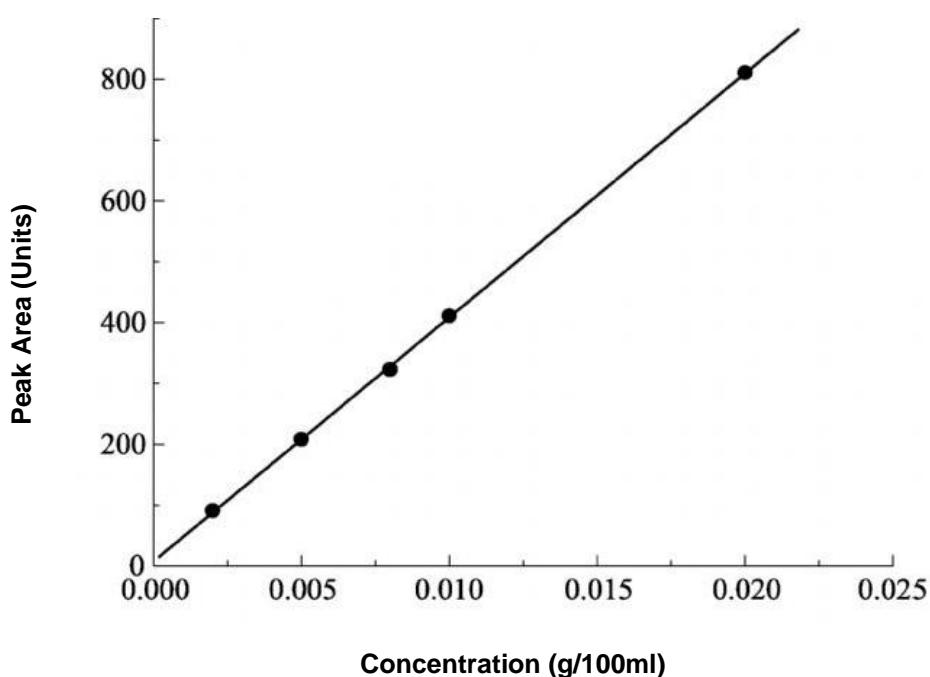

- e. If the peak area of linolenic acid in a sample of rice bran oil prepared in the same manner as the standards is 625 units, what is the concentration of linolenic acid in the oil? State your answer in g L^{-1} . 1 mark

END OF QUESTION AND ANSWER BOOK