



# VCE CHEMISTRY 2017

## YEAR 12 TRIAL EXAM

### CONDITION OF SALE:

© Limited copyright. This paper may be reproduced without charge for use only within the school that has purchased the material. Our electronic copy only may be placed on the school intranet for exclusive use by the teachers and students of the school that has purchased the material. They may **not** otherwise be reproduced (all or part) electronically, scanned into a school computer, forwarded via email, or placed on the Internet, without written consent of the publisher.

### Units 3/4

**Reading time: 15 minutes**

**Writing time: 2 hours 30 minutes**

<i>Section</i>	<i>Number of questions</i>	<i>Number of questions to be answered</i>	<i>Number of marks</i>
A	30	30	30
B	9	9	90
			<b>Total 120</b>

To download the Chemistry Data Book please visit the VCAA website:  
<http://www.vcaa.vic.edu.au/Documents/exams/chemistry/chemdata-w.pdf>

**Learning Materials by Lisachem**  
PO Box 2018, Hampton East, Victoria, 3188  
Ph: (03) 9598 4564 | Fax: (03) 8677 1725  
Email: [orders@learningmaterials.com.au](mailto:orders@learningmaterials.com.au) or [orders@lisachem.com.au](mailto:orders@lisachem.com.au)  
Website: [www.learningmaterials.com.au](http://www.learningmaterials.com.au)



**STUDENT NUMBER**

Figures

Words

Letter

--

Student Name.....

**VCE Chemistry 2017 Year 12 Trial Exam Unit 3/4****Student Answer Sheet**

Instructions for completing test. Use only a 2B pencil. If you make a mistake, erase it and enter the correct answer. Marks will not be deducted for incorrect answers.

Write your answers to the Short Answer Section in the space provided directly below the question. There are **30 Multiple Choice** questions to be answered by circling the correct letter in the table below.

*Question 1*    A    B    C    D*Question 2*    A    B    C    D*Question 3*    A    B    C    D*Question 4*    A    B    C    D*Question 5*    A    B    C    D*Question 6*    A    B    C    D*Question 7*    A    B    C    D*Question 8*    A    B    C    D*Question 9*    A    B    C    D*Question 10*    A    B    C    D*Question 11*    A    B    C    D*Question 12*    A    B    C    D*Question 13*    A    B    C    D*Question 14*    A    B    C    D*Question 15*    A    B    C    D*Question 16*    A    B    C    D*Question 17*    A    B    C    D*Question 18*    A    B    C    D*Question 19*    A    B    C    D*Question 20*    A    B    C    D*Question 21*    A    B    C    D*Question 22*    A    B    C    D*Question 23*    A    B    C    D*Question 24*    A    B    C    D*Question 25*    A    B    C    D*Question 26*    A    B    C    D*Question 27*    A    B    C    D*Question 28*    A    B    C    D*Question 29*    A    B    C    D*Question 30*    A    B    C    D



# VCE Chemistry 2017 Year 12 Trial Exam Unit 3/4

## SECTION A – Multiple Choice Questions

(30 marks)

*Section A consists of 30 multiple-choice questions.  
Choose the response that is **correct** or **best answers** the question.  
A correct answer scores 1, an incorrect answer scores 0.  
No mark is awarded if more than one answer is supplied for a question.  
Indicate your choice on the answer sheet provided.*

### Question 1

At 2300 K the equilibrium constant,  $K_c$ , for the formation of NO(g) according to the equilibrium

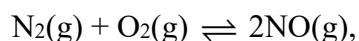

is  $1.7 \times 10^{-3}$

In a particular container at 2300 K the concentration of  $\text{N}_2$  is  $0.50 \text{ mol L}^{-1}$ , the concentration of  $\text{O}_2$  is  $0.25 \text{ mol L}^{-1}$  and the concentration of NO is  $4.2 \times 10^{-3} \text{ mol L}^{-1}$ .

Which of the following statements about the contents of this container is correct?

- A. The rates of the forward and reverse reactions are equal.
- B. The forward reaction is faster than the reverse reaction.
- C. The forward reaction is slower than the reverse reaction.
- D. The total number of molecules in the system is decreasing.

### Question 2

Shown below is an IR spectrum of an organic compound. *SDBSWeb*: <http://sdb.sdb.aist.go.jp> (National Institute of Advanced Industrial Science and Technology, 23/04/2017).

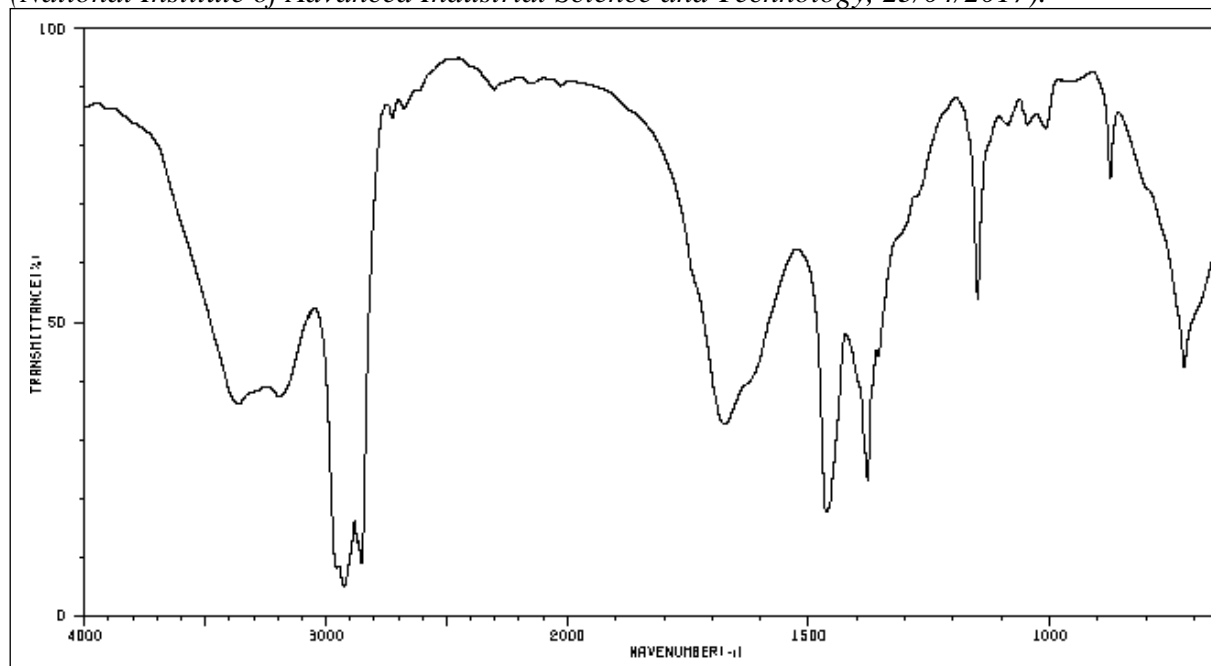

The compound was most likely to be a/an

- A. alcohol.
- B. carboxylic acid.
- C. amide.
- D. aldehyde.

### Question 3

Methane is produced by anaerobic digestion in garbage deposited in landfill and is also a component of coal seam gas. This suggests that methane may be classified as

- A. non-renewable.
- B. renewable.
- C. neither renewable nor non-renewable.
- D. both renewable and non-renewable.

#### Question 4

A student is instructed to determine, experimentally, the mass of ethanol consumed in raising the temperature of 200 mL of water in an open can by 20°C.

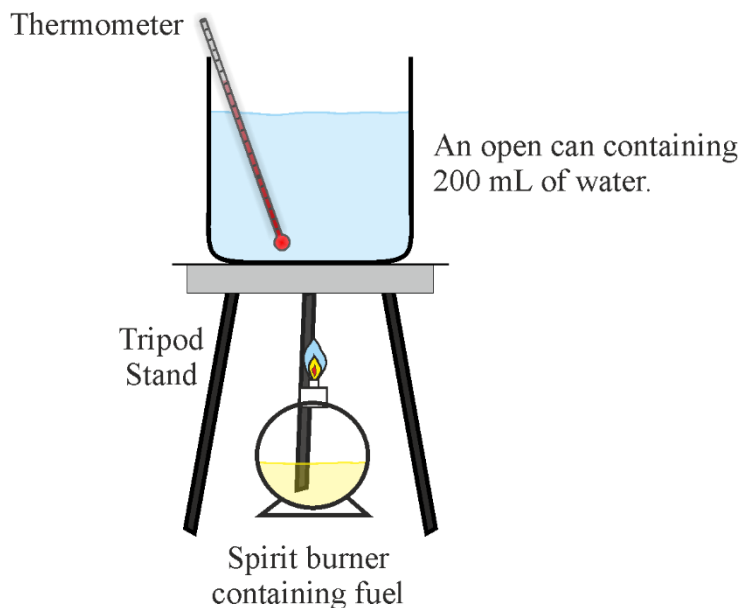

**Figure 1**

The balance used to weigh the spirit burner before and after heating the water was accurate. The spirit burners provided for the experiment all contained methanol, rather than ethanol. Which type of error will the use of the incorrect fuel lead to, and what will be the effect on the mass of fuel consumed in raising the temperature by 20°?

- A. Systematic error, smaller mass of fuel.
- B. Systematic error, larger mass of fuel.
- C. Random error, smaller mass of fuel.
- D. Random error, larger mass of fuel.

#### Question 5

Which of the following substances has molecules which are not chiral?

- A. Cysteine.
- B. Ascorbic acid.
- C. Glycerol.
- D. Alanine.

#### Question 6

Hexadecane,  $C_{16}H_{34}$ , also known as cetane, is a liquid hydrocarbon that may be a component of petrodiesel. The density of cetane is  $0.775 \text{ g mL}^{-1}$ .

What volume, in ML, of carbon dioxide, collected at SLC, would be released during the complete combustion of twenty litres of cetane?

- A. 1.70
- B. 24.6
- C. 27.2
- D. 48.3

### Question 7

Shown in **Figure 2** is the partly annotated energy profile for the complete combustion of one mole of methane.

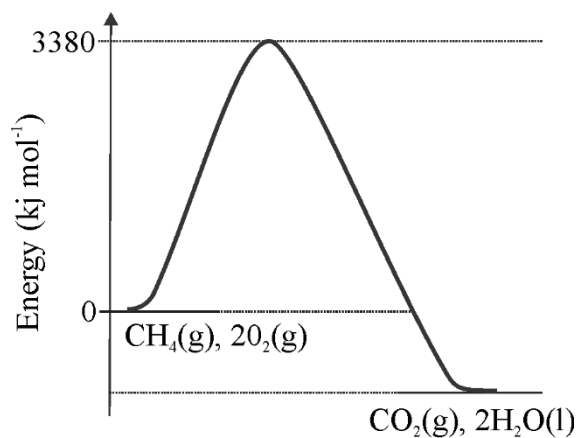

**Figure 2**

The activation energy for the reaction

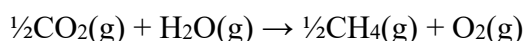

would be

- A. 1635 kJ
- B. 2135 kJ
- C. 2490 kJ
- D. 4270 kJ

### Question 8

Errors associated with the execution of a practical exercise are generally classified as either systematic or random. A commercial vinegar sample is exactly 0.0937 M with respect to ethanoic acid. A laboratory analysis to determine the ethanoic content of the vinegar is performed five times using the same technique, equipment and reagents.

The  $c(\text{CH}_3\text{COOH})$  as determined by the analyses was found to be 0.0901 M, 0.0899 M, 0.0900 M, 0.0902 M, 0.0903 M.

Which of the following best describes the  $c(\text{CH}_3\text{COOH})$  values obtained from the analyses?

- A. Low random error, low systematic error.
- B. Low random error, high systematic error.
- C. High random error, low systematic error.
- D. High random error, high systematic error.

### Question 9

When molecular bromine is added to an aqueous solution of sodium hydroxide, the following equilibrium is established.



Which of the following changes ensues if the equilibrium mixture is cooled? The number of atoms with oxidation number

- A. +1 decreases.
- B. -2 decreases.
- C. -1 increases.
- D. 0 decreases.



### Question 10

Consider the galvanic cell represented below in **Figure 3** at standard conditions.

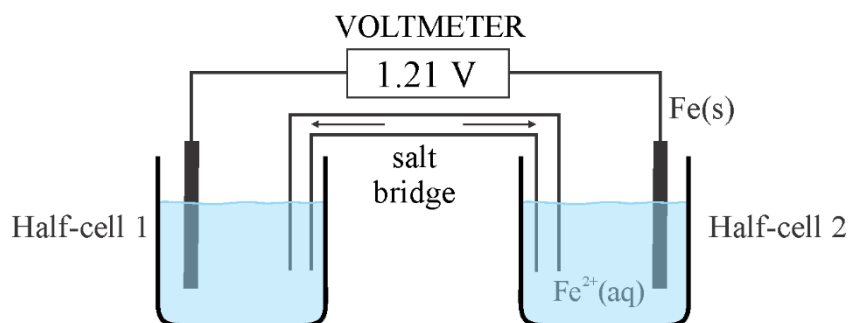

**Figure 3**

Which of the following species would most likely be present in Half-cell 1?

- A. Pt(s) or C(s)
- B.  $\text{Al}^{3+}(\text{aq})$
- C. Fe(s)
- D.  $\text{H}_2(\text{g})$

### Question 11

Temperature and pressure are key factors in the production of common chemicals via equilibrium reactions. The data below show the relationships between percentage yield of product, temperature and pressure for the industrial production of a chemical.

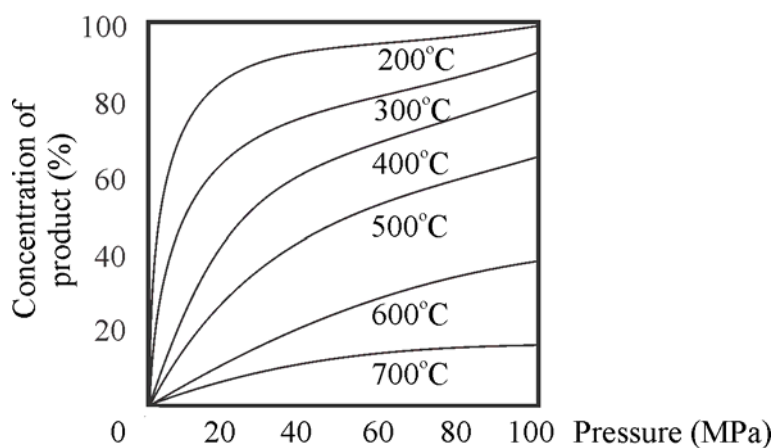
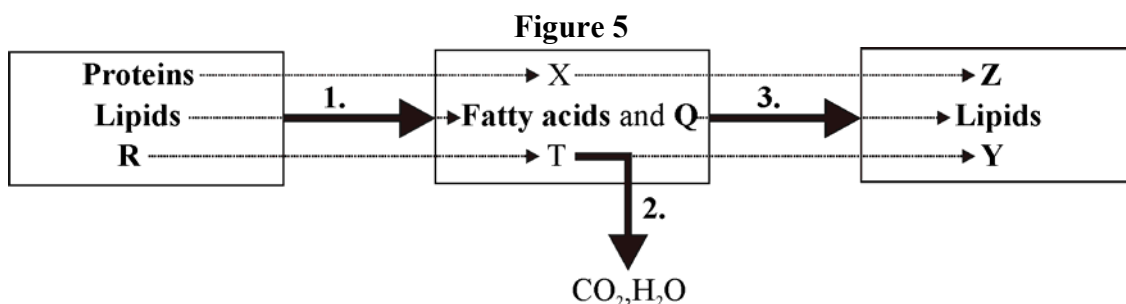

**Figure 4**

According to the data in **Figure 4**, the forward reaction is

- A. exothermic, and the product is on the side with fewer particles.
- B. endothermic, and the product is on the side with more particles.
- C. exothermic, and the product is on the side with more particles.
- D. endothermic, and the product is on the side with fewer particles.

Figure 5 below relates to Questions 12 and 13.



**Figure 5: Digestion of the major dietary food groups**

### Question 12

The reactions represented by **1**, **2**, and **3** are

- A. 1 – condensation, 2 – respiration, 3 – hydrolysis.
- B. 1 – respiration, 2 – hydrolysis, 3 – condensation.
- C. 1 – condensation, 2 – hydrolysis, 3 – respiration.
- D. 1 – hydrolysis, 2 – respiration, 3 – condensation.

### Question 13

The substance containing the greatest percentage, by mass, of oxygen is represented by

- A. Q
- B. X
- C. Y
- D. Z

### Question 14

In January 2017, nine of forty-eight Nickel-hydrogen (Ni-H<sub>2</sub>) batteries used on the International Space Station to store electrical energy generated by the station's solar arrays were replaced by lighter and more efficient lithium-ion batteries.

Ni-H<sub>2</sub> cells using 26 % potassium hydroxide (KOH) as an electrolyte were able to last up to seven years on the space station before being replaced.

One electrode is made up of porous nickel plaque, which contains nickel oxide hydroxide, NiO(OH); the other includes a Teflon-bonded platinum black catalyst.

The half-equation for the reaction occurring at the (+) electrode when this battery is delivering energy is NiOOH(s) + H<sub>2</sub>O(l) + e<sup>-</sup> → Ni(OH)<sub>2</sub>(s) + OH<sup>-</sup>(aq).

The reaction at the (-) electrode is most likely to be

- A. 2H<sub>2</sub>O(l) + 2e<sup>-</sup> → H<sub>2</sub>(g) + 2OH<sup>-</sup>
- B. 2H<sup>+</sup>(aq) + 2e<sup>-</sup> → H<sub>2</sub>(g)
- C. H<sub>2</sub>(g) → 2H<sup>+</sup>(aq) + 2e<sup>-</sup>
- D. H<sub>2</sub>(g) + 2OH<sup>-</sup>(aq) → 2H<sub>2</sub>O(l) + 2e<sup>-</sup>

### Question 15

First generation biofuels can be described as FAMES (fatty acid methyl esters). Second generation biofuels include a renewable diesel, known as green diesel, formed by hydrorefining biological feedstocks such as oils and animal fats. In the process, the feedstock is deoxygenated and hydrogenated to form products with similar composition to petrodiesel. Compared to FAME biodiesel, green diesel would

- A. have a lower energy content per gram of fuel.
- B. be more viscous.
- C. have better cold flow properties.
- D. be more likely to absorb water.

### Question 16

A sample of natural gas is 80 % methane, by volume.

A 2.0 L sample of the natural gas is mixed with excess oxygen and sparked to react to completion.

Assuming all reactant and product volumes are measured at the same temperature and pressure, what is the change in the total volume of greenhouse gases as a result of the combustion reaction?

- A. 1.6 L
- B. 3.2 L
- C. 4.8 L
- D. 6.0 L

### Question 17

Which compound is best represented by the structure below?

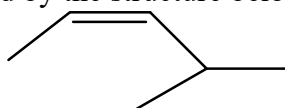

- A. *trans*-2-methylpent-3-ene.
- B. *cis*-4-methylpent-2-ene.
- C. *trans*-4-methylpent-2-ene.
- D. *cis*-2-methylpent-3-ene.

### Question 18

A student's report on the electrolysis of an aqueous solution of copper(II) sulfate under standard conditions includes the following

***'A flow of electricity passed through a solution of copper sulfate in water causes***

- 1. the formation of negatively charged sulfate ions and positively charged copper ions;*
- 2. a metal deposit on the positively charged electrode;*
- 3. water to ionise into positively charged hydrogen ions and negatively charged oxygen ions;*
- 4. oxygen gas to be released into the air.'*

Which of the student's four statements about the effect of a 'flow of electricity passed through an aqueous solution of copper sulfate' is the **most** accurate?

- A. 1
- B. 2
- C. 3
- D. 4

### Question 19

Shown below in **Figure 6** are Maxwell-Boltzmann curves for four different reactions, all occurring at the same temperature.

The activation energies of the four reactions are represented by the symbols  $E_{a1}$ ,  $E_{a2}$ ,  $E_{a3}$  and  $E_{a4}$  respectively.

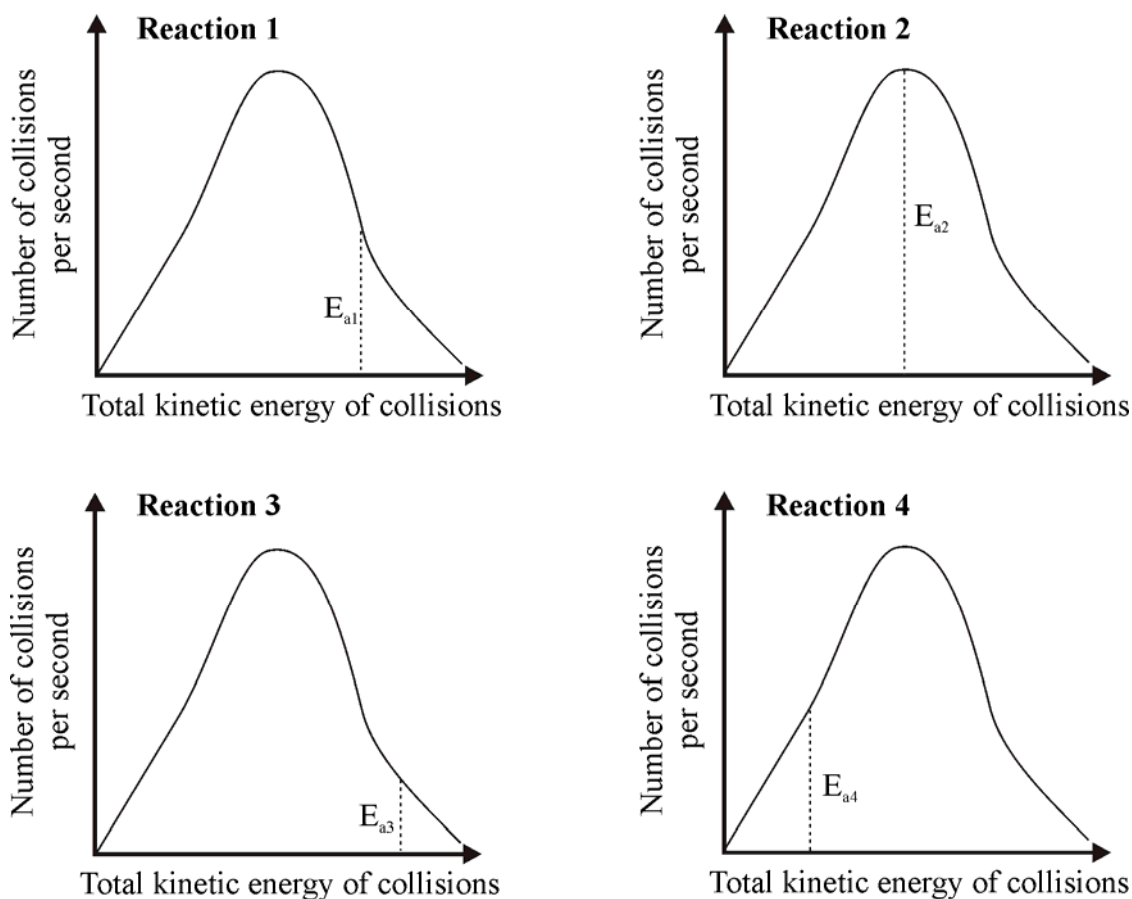

**Figure 6**

The order of reaction rates from slowest to fastest is

- A. Reaction 1 < Reaction 2 < Reaction 3 < Reaction 4.
- B. Reaction 3 < Reaction 1 < Reaction 4 < Reaction 2.
- C. Reaction 4 < Reaction 2 < Reaction 1 < Reaction 3.
- D. Reaction 3 < Reaction 1 < Reaction 2 < Reaction 4.

**Question 20**

Which of the following statements about enzymes is correct?

- A. Some substrates can cause the shape of the active site to change.
- B. The active sites of all enzymes have the same 3-dimensional shape.
- C. Coenzymes have a greater effect on reaction rate than enzymes.
- D. Enzyme activity is increased as pH decreases.

**Question 21**

The longevity of a good wine is related to its acid content. Wines which age well show an increase in pH over time. Such wines will have a higher acid content, when bottled, than wines produced for immediate consumption. Whilst adding ascorbic acid to white wines increases their acid content, that is not the role it plays in ensuring the longevity of the wine. The likely role of ascorbic acid in wine is to act as

- A. a source of Vitamin C to reduce the effect of alcohol on the liver.
- B. an emulsifier and draw all the sediment in the wine to the bottom of the bottle.
- C. a reductant and so reduce the chance of the wine deteriorating due to the impact of free radicals.
- D. bactericide to kill any bacteria that might be present in the bottle closure (cork or screw top).

### Question 22

The three spectra below relate to the same organic compound.

SDBSWeb: <http://sdb.sdb.aist.go.jp> (National Institute of Advanced Industrial Science and Technology, 14/03/2017).

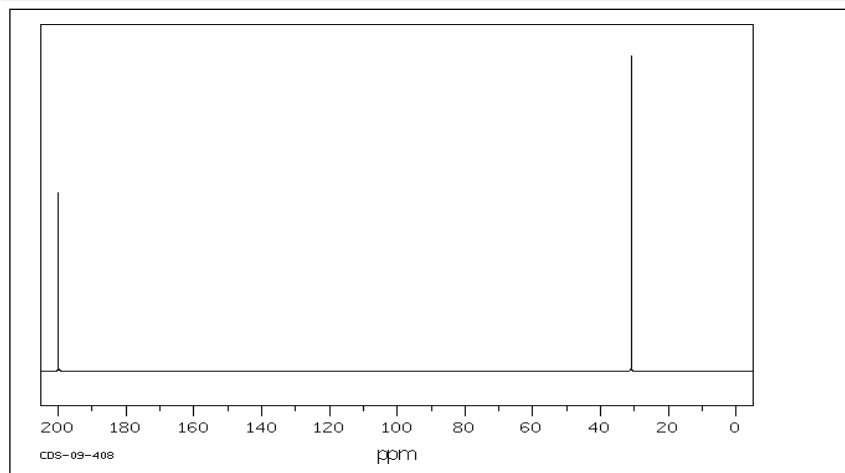
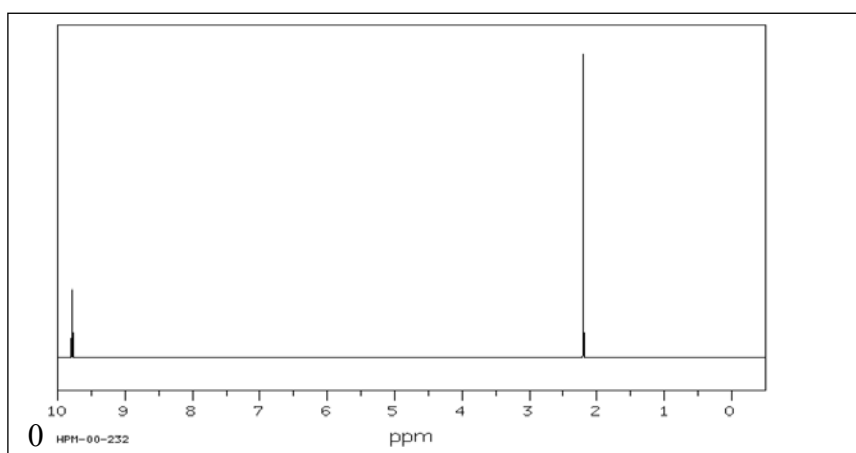
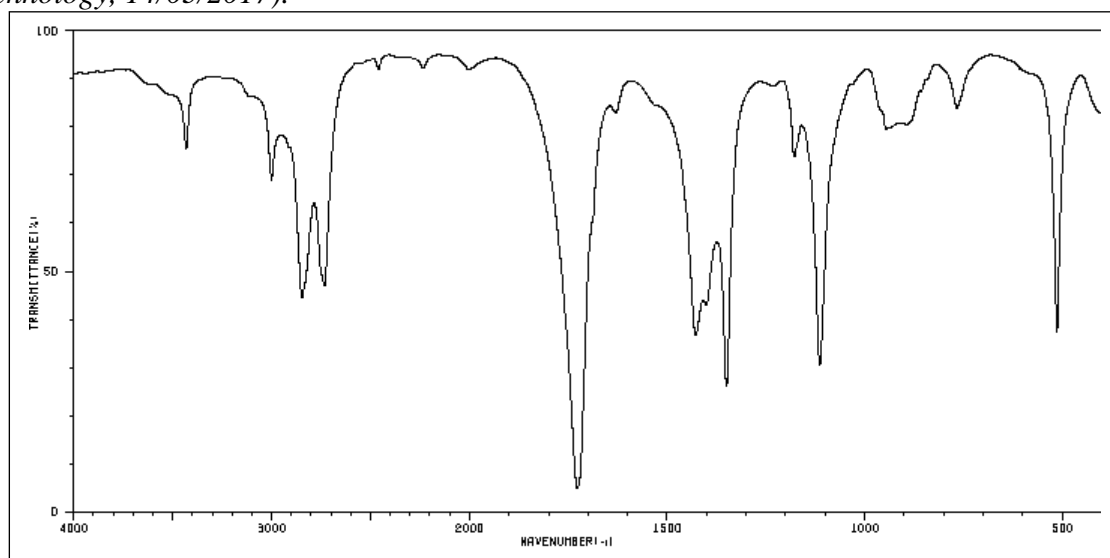

According to this information the semi-structural formula of the compound is most likely to be

- A.  $\text{CH}_3\text{COOH}$
- B.  $\text{CH}_3\text{COCH}_3$
- C.  $\text{CH}_3\text{CHO}$
- D.  $\text{CH}_3\text{CH}_2\text{OH}$

### Question 23

Graphical representation of data and concepts is an important component of chemistry. Consider the graphs below on which the Y-axis is unlabelled.

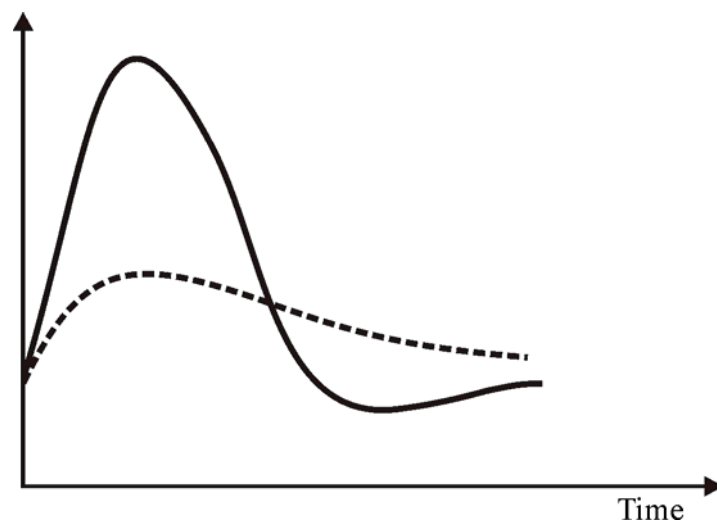

Figure 7

Which of the following options do the graphs in **Figure 7** best represent?

- A. The effect of temperature on particle collisions.
- B. The change in blood glucose levels during digestion.
- C. The effect of a catalyst on activation energy.
- D. Energy profiles for exothermic and endothermic reactions.

### Question 24

Hazelwood Power station was a 1600 MW (megawatt – 1 MW = 1000 kJ s<sup>-1</sup>) Victorian brown-coal fired power station that was decommissioned in the first half of 2017.

If a methane-fired gas power station, operating at 60 per cent efficiency, produced electrical energy at the same rate, the volume of CH<sub>4</sub>, measured in ML at 30°C and 150 kPa, used in one hour would be

- A. 64.8
- B.  $1.08 \times 10^2$
- C.  $1.81 \times 10^2$
- D.  $5.76 \times 10^3$

### Question 25

Many of the venoms injected by spiders such as redbacks are cocktails of proteins that interfere with nerve transmission and cellular function. Snake venoms and box jellyfish stinging elements contain potent mixes of poisonous proteins, enzymes and polypeptides. Whilst antivenoms exist for most snake venoms, no such option is available for jellyfish stings.

Which of the following treatments would be **least** effective in reducing the impact of jellyfish stings?

- A. Bathing the affected area with a concentrated solution of inorganic ions.
- B. Bathing the affected with vinegar solution.
- C. Applying hot water, as hot as the victim can tolerate.
- D. Applying ice packs.

### Question 26

As part of an analysis of a mixture of vitamins D<sub>2</sub> and D<sub>3</sub> by HPLC, the following chromatogram was recorded.

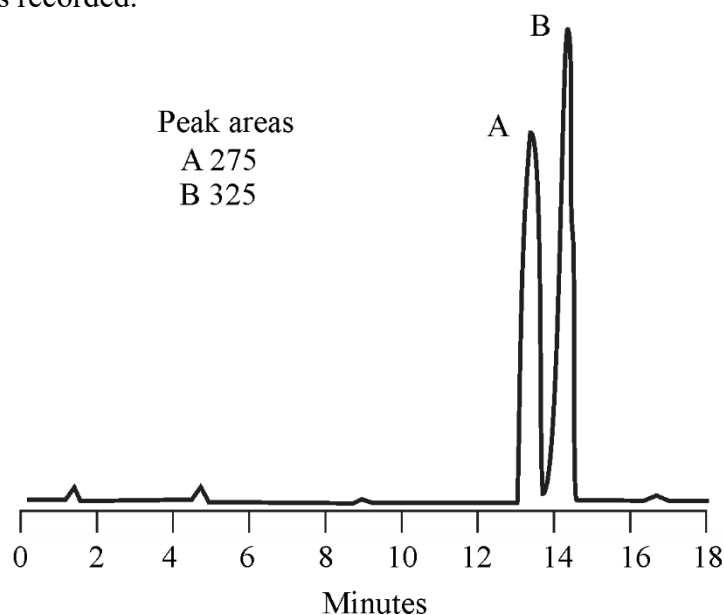

**Figure 8**

Tests showed that vitamin D<sub>3</sub> had the higher retention time.

Two sets of standards of known concentration of each of the vitamin D forms present were prepared and run through the same chromatograph. The calibration curves below were established from the data.

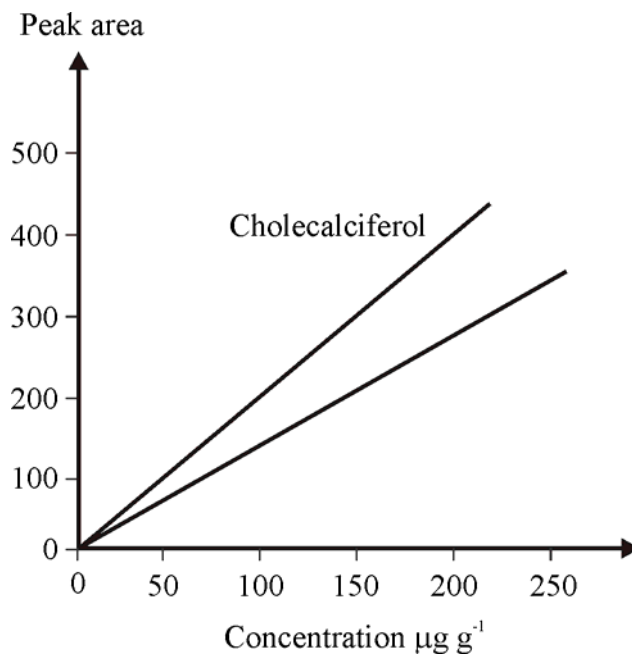

**Figure 9**

Based on the information in **Figure 9**, the mass of vitamin D<sub>2</sub> in 50 g of the mixture would be closest to

- A. 6 mg
- B. 7 mg
- C. 9 mg
- D. 10 mg



### Question 27

Combustion is not an immediate process after fuel injection in a diesel engine leading to ignition delay. Cetane number is used to represent the combustion quality of diesel fuel during compression ignition. Increased cetane number reduces ignition delay. Fuel additives based on levulinic acid can be used to replace current unsustainable cetane improvers. Levulinic acid is a sustainable ‘platform chemical’ because it can be produced from wood chips, straw and plant waste, and used to make a variety of other valuable products. The structure of levulinic acid is represented below.

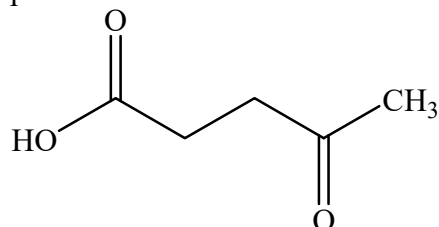

Levulinic acid can be produced by heating fructose in dilute sulfuric acid. The overall reaction may be summarised as

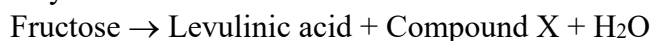

The atom economy for the production of levulinic acid based on this chemical equation is closest to

- A. 48 per cent.
- B. 64 per cent.
- C. 74 per cent.
- D. 83 per cent.

### Question 28

Lactic acid,  $\text{C}_3\text{H}_6\text{O}_3$ , is formed from the incomplete oxidation of glucose during anaerobic activity. Whilst lactic acid has the same proportion of C, H and O as many carbohydrates, it is technically not a carbohydrate. Its heat of combustion to 2 significant figures is  $15 \text{ kJ g}^{-1}$ .

A bomb calorimeter was used to investigate the energy content of lactic acid.

The following procedure was followed:

1. The calorimeter was calibrated by allowing a sample of ethanol to react completely with oxygen in the calorimeter. The energy released caused the temperature of the water surrounding the reaction bomb to change from  $23.1^\circ\text{C}$  to  $35.4^\circ\text{C}$ .
2. A  $5.865 \text{ g}$  sample of pure lactic acid was later reacted completely with oxygen in the same calorimeter. The energy released caused the temperature of the water to change from  $28.7^\circ\text{C}$  to  $39.2^\circ\text{C}$ .

Assuming the calorimeter was 100 per cent efficient, which of the following would be closest to the mass of ethanol consumed during calibration?

- A. 2.5 g
- B. 3.5 g
- C. 4.8 g
- D. 5.6 g

### Question 29

As well as providing energy for ignition, engine starting and lighting, the modern automobile battery also provides energy for power steering and windows, entertainment and GPS units, anti-lock brakes, cruise control, airbag sensors, air conditioning and demisters. It must recharge when the automobile is being driven.

The common 12 V lead acid car battery makes up around 40 per cent of worldwide annual battery sales. These batteries each contain 6 lead-acid cells, in which, during discharge, the following half-reactions occur.

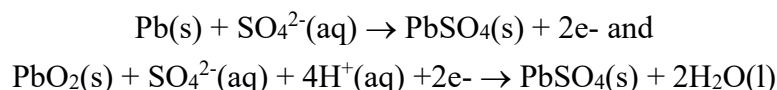

When a car battery is recharging,

- A. Pb is produced at the negative electrode of each cell.
- B. the pH in each cell increases.
- C. PbSO<sub>4</sub> is produced at the positive electrode in each cell.
- D. the changes in the oxidation numbers of lead are from 0 to +2 and +4 to +2.

### Question 30

Glutathione, common in animals and bacteria, is a natural scavenger of free radicals. As such it is part of the body's natural defence system. Viruses, bacteria, heavy metal toxicity, radiation, certain medications, and even the normal process of aging can all cause free-radical damage to healthy cells and deplete glutathione. Glutathione depletion has been linked with lower immune function and infection resistance.

Glutathione levels in humans tend to peak around the age of twenty, however foods such as avocados, broccoli, tomatoes, garlic and many others are natural sources.

The structure of glutathione is represented below.

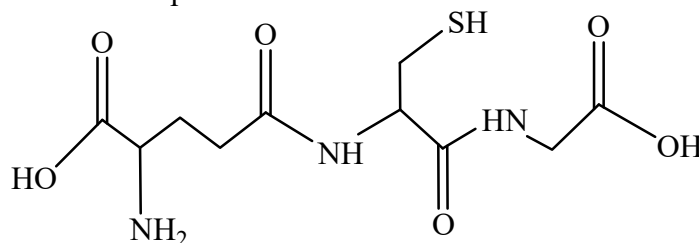

Which of the following statements about glutathione is **least** accurate?

- A. Glutathione is an antioxidant.
- B. Glutathione is a tripeptide.
- C. Glutathione molecules contain four different functional groups.
- D. Glutathione molecules are formed from only two 2-amino acids.

**End of Section A**

# VCE Chemistry 2017 Year 12 Trial Exam Unit 3/4

## SECTION B – Short Answer Questions

(90 marks)

*Section B consists of 9 short answer questions.  
You should answer all of these questions in the spaces provided.  
The allotted **marks** are shown at the end of each part of each question.*

### Question 1 (11 marks)

Methanol is a reactant in the production of biodiesel by transesterification. It can also be used to improve combustion quality of petrodiesel and reduce ignition delay.

Methanol is also an effective fuel in its own right.

a. Write a balanced thermochemical equation for the combustion of methanol. **1 mark**

b. A laboratory experiment was set up to determine the heat of combustion of methanol. Methanol was burned in a ‘spirit burner’ and heat released was used to heat 200 mL of water. The apparatus was set up as shown in **Figure 10**.

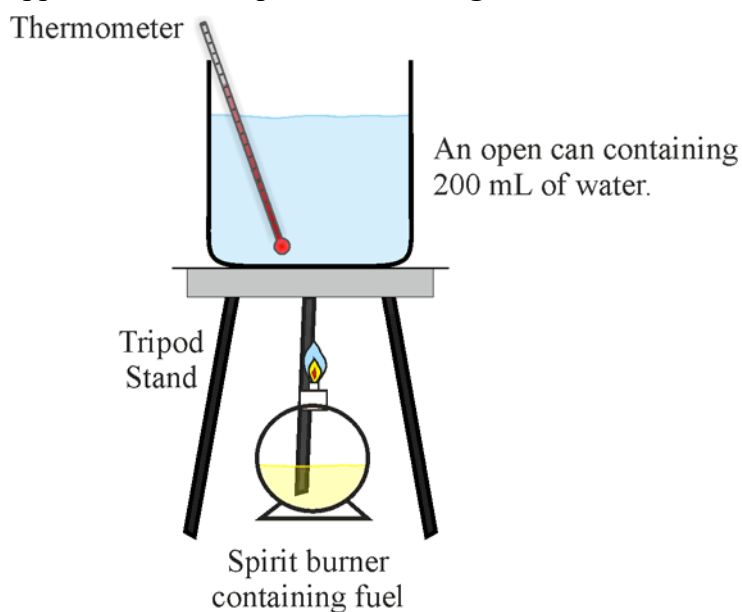

**Figure 10**

The following data were recorded:

Mass of spirit burner before heating: 125.62 g

Mass of spirit burner after heating: 121.56 g

Temperature of water before heating: 23.5°C

Temperature of water after heating: 54.7°C

- i.** Calculate the percentage of the energy released during the burning of the methanol that was transferred to the water in the can. **3 marks**
- ii.** Describe and explain one modification that could improve the overall efficiency of the energy transfer to the water in the can. **1 mark**
- c.** Methanol can also be used as the ‘fuel’ in a fuel cell using hydrochloric acid as an electrolyte. The overall equation for the fuel cell is the same as the combustion equation.
- i.** Write balanced half-equations for the reactions occurring at **2 marks**
- (-) electrode.
- (+) electrode.
- ii.** State an advantage of the use of porous electrodes in fuel cells, and identify one other factor that influences the choice of electrode. **1 mark**

- d.** BioDME (dimethyl ether) -  $\text{CH}_3\text{OCH}_3$  - can be produced by first converting biomass to syngas, a mixture of CO and  $\text{H}_2$ , followed by a two-step process.

The syngas is converted to methanol



and methanol is dehydrated to DME

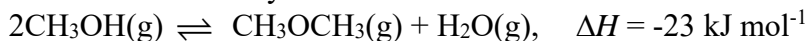

- i.** Explain why the use of a catalyst is particularly beneficial in both steps. **2 marks**

- ii.** BioDME, a second-generation biofuel, has been shown to have better ignitability in compression ignition engines and is considered to be a feasible alternative to petrodiesel and some other biodiesels. A significant problem encountered when engines are fuelled with DME is that the injection equipment breaks down prematurely due to extensive wear. This behaviour can be explained by the low viscosity of DME. Explain why bioDME has much lower viscosity than a biofuel such as methyl stearate ( $\text{C}_{17}\text{H}_{35}\text{COOCH}_3$ ). **1 mark**

**Question 2 (8 marks)**

In an experimental study of the reaction between marble chips (calcium carbonate) and hydrochloric acid, the following data in **Table 1** were recorded.

Reaction time min : sec	Mass loss during reaction (grams)		
	Investigation 1	Investigation 2	Investigation 3
0	0.000	0.000	0.000
0 : 30	0.457	0.797	0.157
1 : 00	0.702	0.925	0.292
1 : 30	0.822	0.951	0.369
2 : 00	0.880	0.963	0.410
2 : 30	0.913	0.970	0.433
3 : 00	0.932	0.975	0.446
4 : 00	0.953	0.984	0.467
5 : 00	0.965	0.991	0.482
6 : 00	0.975	0.998	0.493
7 : 00	0.983	1.003	0.502
8 : 00	0.990	1.009	0.511
9 : 00	0.996	1.014	0.519
10 : 00	1.001	1.018	0.525

**Table 1**

In all three investigations

- 20.0 g of marble chips and 25 mL of hydrochloric acid were used and no catalyst was added.
- the reactants were at the same temperature.
- hydrochloric acid was the limiting reactant.

- a. Write a balanced equation for the reaction between calcium carbonate and hydrochloric acid.

**1 mark**

- b. The recorded data are represented on the graphs in **Figure 11**.

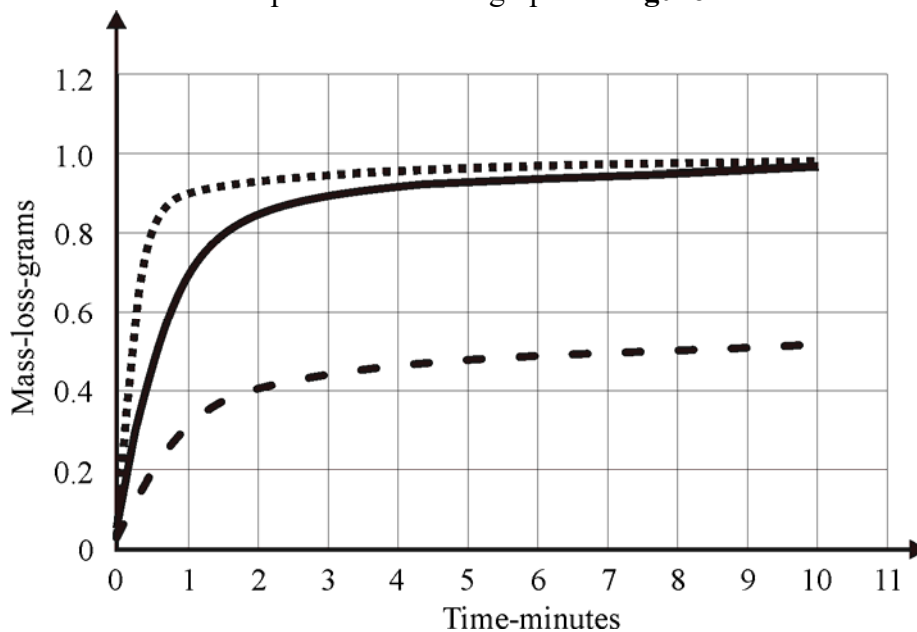

**Figure 11**

- i. Overall, what do the data for all three investigations indicate about the relationship between reaction rate and time? **1 mark**
- ii. Explain this relationship in terms of collision theory. **1 mark**
- c. In investigations 2 and 3, one factor impacting the initial rate of reaction – a different one for each investigation – was changed compared to Investigation 1.
- i. Identify the factor that was changed for Investigation 2 and explain how this was deduced from the information and data supplied. **2 marks**

- ii. Identify the factor that was changed for Investigation 3 and explain why the data for this investigation are significantly different to the data for the other two investigations.

**1 mark**

- d. For the two pairs of investigations, '1 and 2' and '1 and 3', identify the Controlled, Independent and Dependent variables and list them in **Table 2**.

**2 marks**

Investigations	Independent variables	Dependent variables	Controlled variables
1 and 2			
1 and 3			

**Table 2**



**Question 3 (7 marks)**

**Figure 12** below represents an ‘idealised’ outcome at one electrode of the extended electrolysis, using graphite electrodes, of an aqueous solution containing  $\text{Cu}(\text{NO}_3)_2$ ,  $\text{AgNO}_3$  and  $\text{KNO}_3$  which is 0.100 M for all three compounds.

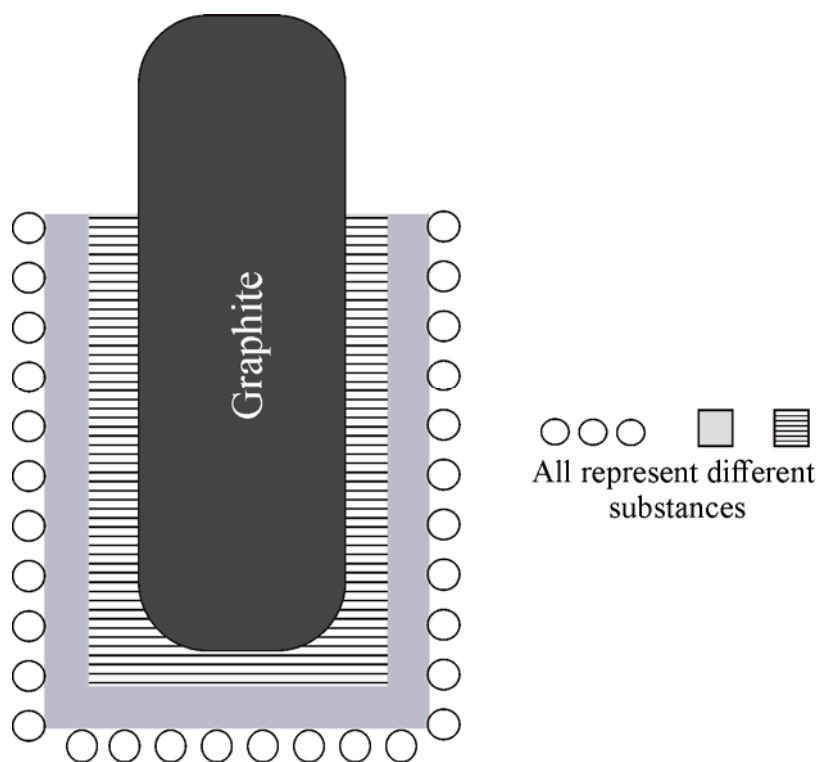

**Figure 12**

- a.** Is this graphite electrode the anode or the cathode? Explain how you identified the function of this electrode.

**1 mark**

- b. i.** Identify the substance produced first at this electrode and explain why it is the first to be deposited.

**1 mark**

- ii.** Identify the second substance produced at this electrode and explain when it is deposited and why it is the second substance deposited. **1 mark**
- iii.** Write a balanced half-equation for the production of the third substance formed at this electrode. **1 mark**
- c.** Explain why the diagram given is very much an ‘ideal’ representation of the reactions occurring at this electrode during the electrolysis. **1 mark**
- d.** Write a balanced half-equation(s) for the reaction(s) occurring at the other electrode during the electrolysis. **1 mark**
- e.** What effect does the electrolysis have on the total cation concentration in the solution? Explain. **1 mark**

**Question 4 (7 marks)**

Haemoglobin is a protein that is used to carry oxygen through the blood stream from the lungs to the tissues. Haemoglobin has a lower affinity for oxygen the lower the concentration of oxygen gets. **Haemoglobin** consists of four subunits, each with a cofactor called a heme group that has an iron atom center. The iron is the main component that actually binds to oxygen, thus each haemoglobin molecule is able to carry four molecules of O<sub>2</sub>.

The haemoglobin-O<sub>2</sub> equilibrium in the blood may be represented by the simple equilibrium

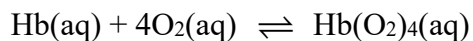

Carbon monoxide, even in very low concentrations, is highly toxic because it blocks the transport of O<sub>2</sub> through the body.

- a. What is the most common source of carbon monoxide exposure? Write a supporting balanced equation.

**2 marks**

- b. In terms of competing equilibria, explain how carbon monoxide interacts with the haemoglobin-oxygen equilibrium given above.

**2 marks**

c. Use equilibrium principles to explain why 100 per cent oxygen therapy is used to treat carbon-monoxide poisoning. **1 mark**

d. Explain why haemoglobin is described as a quaternary protein. **1 mark**

e. Carbon dioxide plays a more productive role than CO in the body via the equilibrium sequence

$$\text{CO}_2(\text{g}) \rightleftharpoons \text{CO}_2(\text{aq}) + \text{H}_2\text{O}(\text{l}) \rightleftharpoons \text{H}_2\text{CO}_3(\text{aq}) + \text{H}_2\text{O}(\text{l}) \rightleftharpoons \text{H}_3\text{O}^+(\text{aq}) + \text{HCO}_3^-(\text{aq})$$

which is important in maintaining blood pH within healthy limits.  
Explain how the system adjusting to blood pH that is too low will impact on the amount of  $\text{CO}_2(\text{g})$  exhaled. **1 mark**

**Question 5 (8 marks)**

Ammonia,  $\text{NH}_3$ , is manufactured from nitrogen and hydrogen by the Haber process according to the following equilibrium

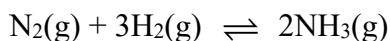

The data in **Table 3** give approximate values for the percentage yield of ammonia at various temperatures and pressures.

Temperature ( $^{\circ}\text{C}$ )	Pressure (kPa)	% of $\text{NH}_3$ at equilibrium
400	$2.00 \times 10^5$	36.3
400	$3.00 \times 10^5$	49.2
400	$4.00 \times 10^5$	56.5
300	$2.00 \times 10^5$	62.8
500	$2.00 \times 10^5$	17.6

**Table 3**

Use the data in **Table 3** to help you answer the following questions:

- a.** Explain why the observed effect of pressure upon the yield of ammonia is consistent with Le Chatelier's principle. **2 marks**
- b.** Write the equilibrium constant expression,  $K_c$ , for the formation of ammonia. **1 mark**
- c.** What is the thermochemical nature of the ammonia producing reaction? Explain. **1 mark**
- d.** Explain how the introduction of a catalyst would impact on the equilibrium yield of  $\text{NH}_3$ . **1 mark**

The rate-time graphs shown in **Figure 13** are related to the impact of an instantaneous volume decrease, at time 't' on the Haber process equilibrium.

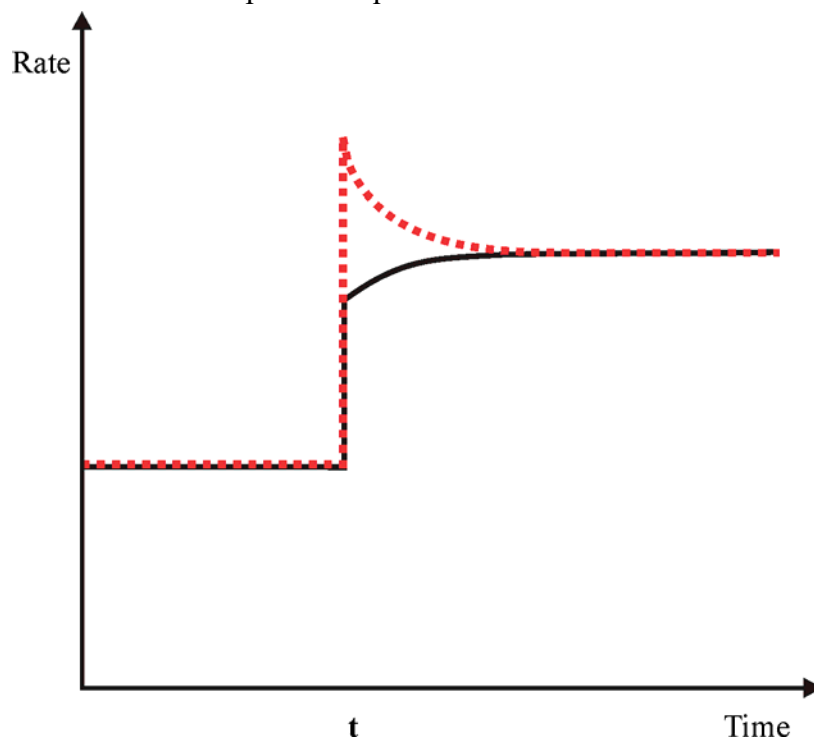

**Figure 13**

- e. Explain the shapes of these graphs in **Figure 13** and indicate which of the two graphs represent the forward and reverse reactions respectively.

**3 marks**

**Question 6 (17 marks)**

Olive oil is a pale yellow or greenish liquid extracted from the fruit of the olive tree *Olea Europaea*. The nutrition information label on a 750 mL bottle of 'Cobram Estate' Australian Extra Virgin Olive oil includes the following data applying to a 15 mL serving

Energy	517 kJ
Fat total	13.7 g
Saturated	2.1 g
Monounsaturated	10.2 g
Polyunsaturated	1.4 g
Total polyphenols	8 mg

Consider the fat represented by the structure below.

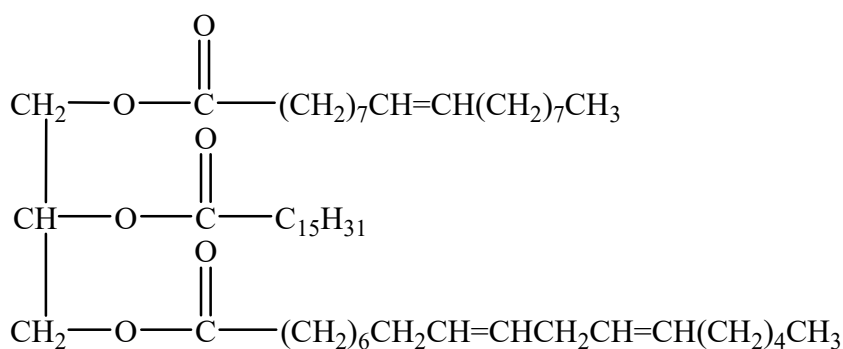

a. i. Explain how such molecules are digested. **2 marks**

ii. Name **two** of the initial products of the digestion of the molecule shown and indicate how these products relate to the information shown on the nutrition information label. **2 marks**

iii. Explain why the term omega-6 applies to one of the digestion products. **1 mark**

iv. Name, and give the semistructural formula of a similar compound to which the term omega-3 applies. 1 mark

b. Write a balanced equation describing the complete combustion of the fat represented in Question 6ai. 2 marks

c. High quality extra virgin olive oils have a slightly bitter spicy taste associated with antioxidant polyphenols.

i. Why are antioxidants added to olive oils? 2 marks

Hydroxytyrosol, a polyphenol present in olive oil as shown below, does not have optical isomers.

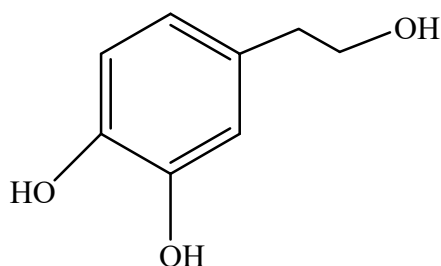

ii. Vitamin C, also an antioxidant, is an enantiomer of ascorbic acid. Use the structures of the two compounds to explain this difference. 2 marks

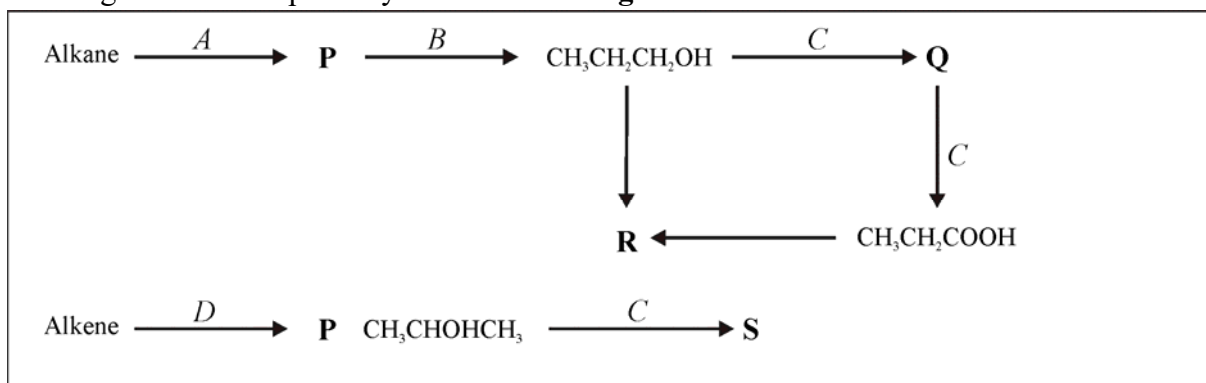

- d.** If 7.5 mL of ‘*Cobram Estate*’ Australian Extra Virgin Olive oil is used to heat 500 mL of water, and the transfer of thermal energy to the water is 40 % efficient, what will be the temperature change in the water? **3 marks**
- e.** Calculate the density, in  $\text{g mL}^{-1}$  of ‘*Cobram Estate*’ Australian Extra Virgin Olive oil utilising relevant information supplied in the *VCE Data Book* in your calculation. **2 marks**

**Question 7 (10 marks)**Two organic reaction pathways are shown in **Figure 14**.**Figure 14**

- a. Write the semi structural formulae of compounds represented by **Q**, **R** and **S**. **3 marks**
- Q
- R
- S
- b. Give the chemical formulae of the reagents represented by **B**, **C** and **D**. **3 marks**
- B
- C
- D
- c. Write balanced half-equations describing the production of **S**. **2 marks**
- d. In an investigation of the reaction to produce compound **R** using equal chemical amounts of each reactant, equilibrium was achieved when 75 per cent of the reactants were consumed. Determine the associated equilibrium constant. **2 marks**

**Question 8 (11 marks)**

The structures below represent citric acid and oxalic acid. Citric acid is triprotic and oxalic acid is diprotic.

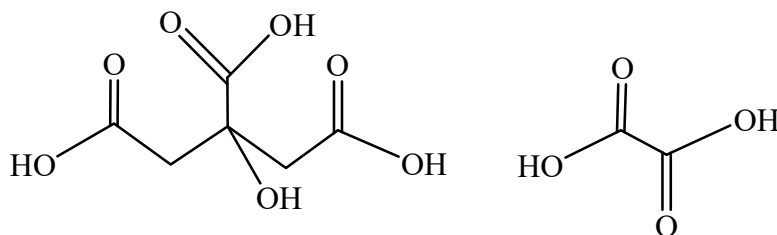

Asked to design an analysis technique for the citric acid content of designated fruit juice, a group of chemistry students present the following summary of a procedure:

1. Make up 500 mL of a 1.00 M solution of NaOH.
2. Weigh out three 2.50 g samples of oxalic acid and add each one to 50 mL of water in a 250 mL flask.
3. Titrate each of the three oxalic acid solutions with the NaOH(aq) solution to the phenolphthalein endpoint.
4. Add a 50.0 mL sample of the fruit juice to each of three 250 mL flasks.
5. Titrate each of the three fruit samples to the phenolphthalein end point with the NaOH solution prepared in 1.
6. Calculate the citric acid content of the fruit juice in g L<sup>-1</sup>.

The procedure as described was followed and **Table 4** displays the data recorded.

<i>m</i> (C <sub>2</sub> H <sub>2</sub> O <sub>4</sub> )	<i>V</i> (NaOH) for oxalic acid samples	<i>V</i> (NaOH) required for juice samples
1.25 g	27.6 mL	33.6 mL
1.23 g	27.1 mL	33.4 mL
1.26 g	27.4 mL	33.9 mL

**Table 4**

- a. Write balanced equations using molecular formulae for the reactions between:
- i. Oxalic acid and the sodium hydroxide solution. **1 mark**
  
  - ii. Citric acid and the sodium hydroxide solution. **1 mark**
- b. Are the recorded data appropriately presented? Explain. **1 mark**

- c. Given that oxalic acid is not present in the fruit juice, why would it have been used in the analytical procedure? **1 mark**
- d. Calculate the accurate molar concentration of the NaOH(aq) used in the titration. **3 marks**
- e. Calculate the concentration of citric acid content of the fruit juice, in g L<sup>-1</sup>. **3 marks**

Further analysis of the fruit juice used shows it to contain significant amounts of malic acid. The structure of malic acid is represented below.

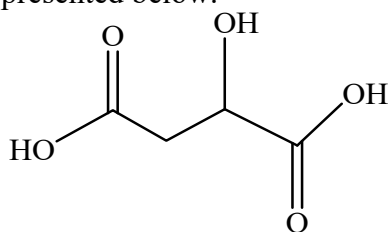

- f. Explain how the presence of significant amounts of malic acid in the fruit juice would affect the calculated concentration of citric acid? **1 mark**

### Question 9 (11 marks)

The three spectra shown below were an integral part of an analysis exercise to verify the structure of an organic compound. *SDBSWeb*: <http://sdb.sdb.aist.go.jp> (National Institute of Advanced Industrial Science and Technology, May 2, 2017).

#### Mass Spectrum

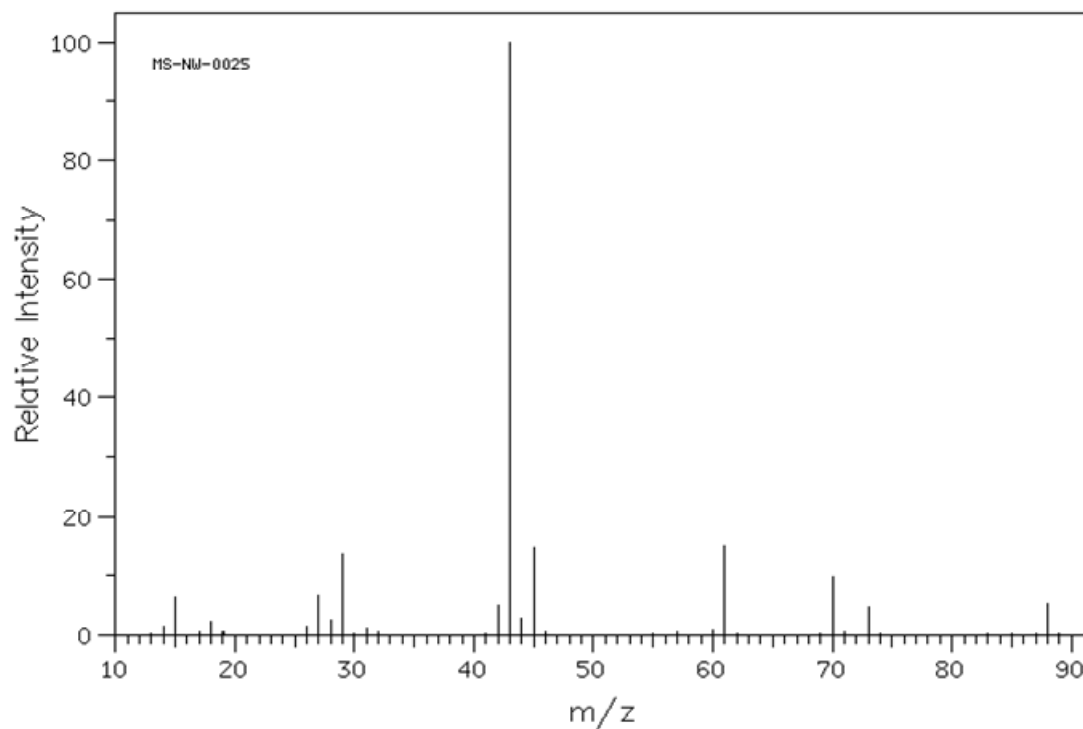

#### <sup>13</sup>C Spectrum

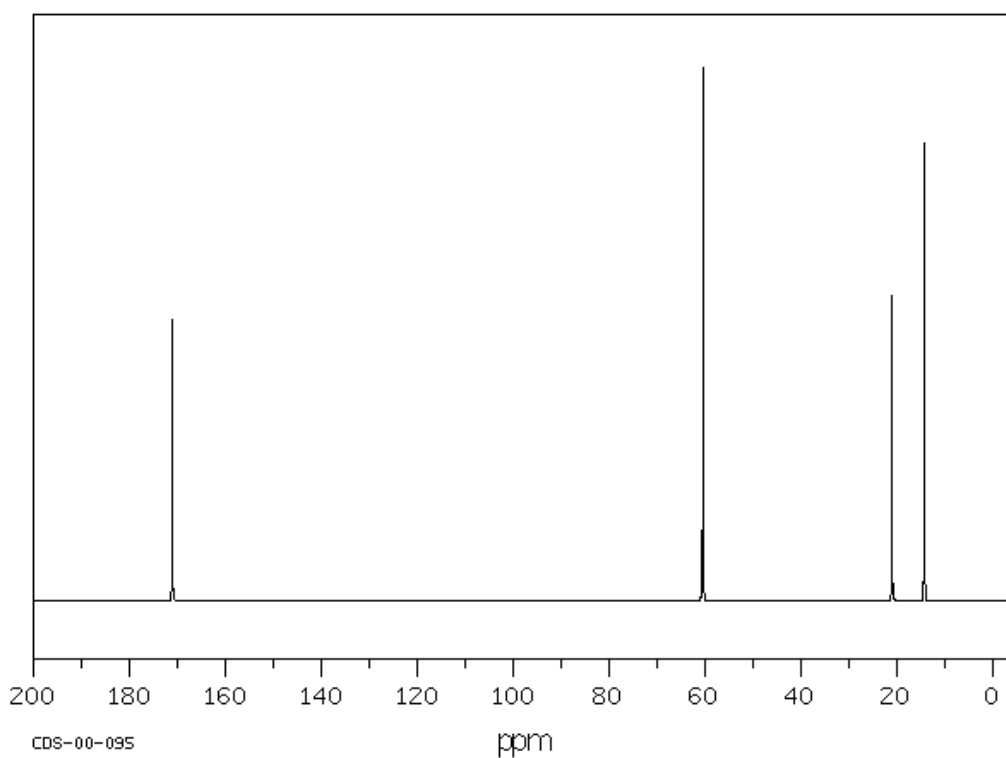

## $^1\text{H}$ NMR Spectrum

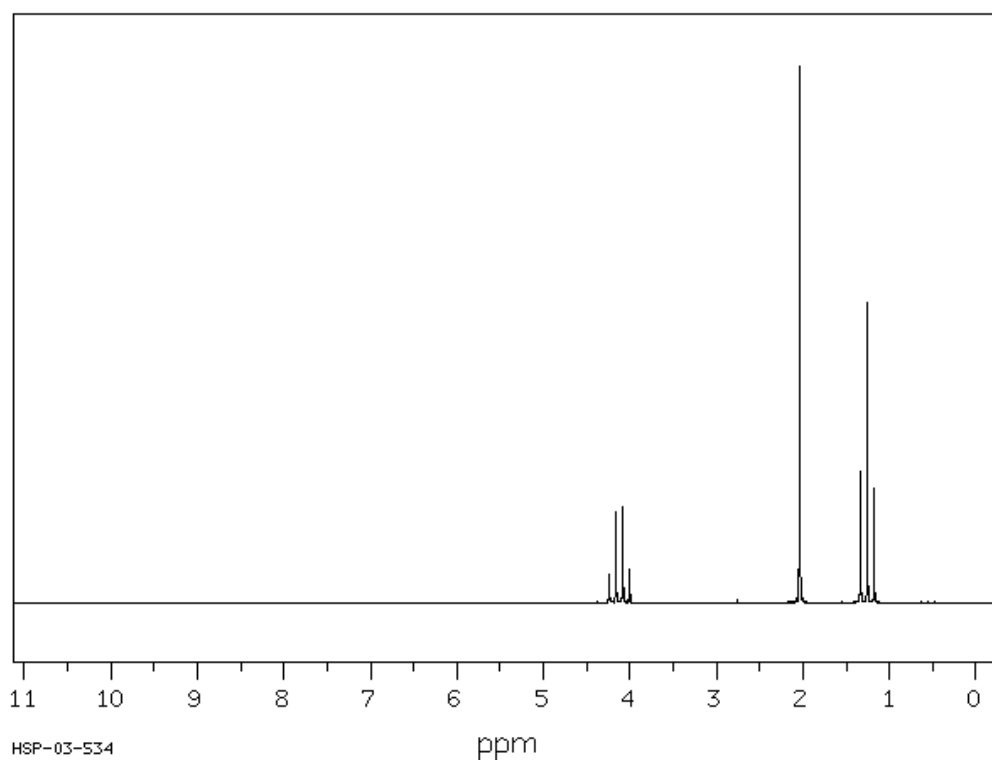

- a.** Give the two most significant pieces of data that may be deduced about the compound from the mass spectrum. **2 marks**
- b.** What does the  $^{13}\text{C}$  spectrum indicate about the compound? **1 mark**
- c.** Identify all the useful information about the structure of the compound that may be deduced from the  $^1\text{H}$  NMR spectrum. **3 marks**

- d.** Molecules of the compound contain three different elements. Using all the available information, determine a semi-structural formula for the compound. **2 marks**
- e.** Give the wave-number bands of two significant peaks that should appear on the IR spectrum of this compound. **1 mark**
- f.** The compound has at least one structural isomer containing a different functional group. Identify one of these isomers and describe how the  $^1\text{H}$  NMR spectrum of the isomer would differ from the  $^1\text{H}$  NMR spectrum of the compound. **2 marks**

**End of Section B**

**End of Trial Exam**

**Question 10 (13 marks) – BONUS QUESTION**

The artificial sweetener Aspartame has two enantiomers, one of which, L-aspartame, tastes sweet whilst the other, D-aspartame, is tasteless.

- a. How many chiral carbons are present on an aspartame molecule? **1 mark**
- b. Describe the structural change that occurs when the pH of an aqueous solution of aspartame changes from 10 to 4. **2 marks**
- c. Comment on the relative interactions of the two aspartame enantiomers with our taste buds. **1 mark**
- d. Both aspartame and sucrose (common sugar) undergo hydrolysis reactions in the body.
- i. Describe the functional group changes that occur during these hydrolyses. **2 marks**
- ii. Name the products of the hydrolysis of aspartame. **2 marks**
- iii. Name the products of hydrolysis of sucrose. **2 marks**
- iv. One of the products of the hydrolysis of sucrose is also a product of the hydrolysis of starch. Explain the link between the glycaemic index (GI) of foods and the structure of starch. **3 marks**

**End of Bonus Question**