

CHEMISTRY

Unit 2 – Written examination



2013 Trial Examination

SOLUTIONS

SECTION A – Multiple choice (1 mark each)

Question 1

Answer: D

Explanation

Option A and C contain hydrocarbons which are nonpolar and thus, are not soluble in water. Option B contains silicon dioxide which has a network lattice and is insoluble.

Question 2

Answer: D

Explanation

Moisture (presence of water) actually speeds up the corrosion process.

Question 3

Answer: B

Explanation

According to the Bronsted-Lowry theory, an acid is a substance that donates a proton.

Question 4

Answer: C

Explanation

The conjugate base for this ion is a substance that has one less proton than HSO_4^-

Question 5

Answer: A

Explanation

Possible products of switching the partners on these two reactants are silver chloride and potassium nitrate. As all nitrate compounds are soluble, the silver chloride is the only plausible answer. All chloride, bromide and iodide compounds of silver are insoluble.

Question 6

Answer: D

Explanation

The lowest pH arises from the most acidic substance listed (the one that will create the most H_3O^+ ions). As ethanoic acid is a weak acid, this rules out options A and B. H_2SO_4 will create more H_3O^+ ions than the HCl at the same concentration, as it is diprotic.

Question 7

Answer: D

Explanation

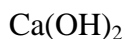

$$[\text{OH}^-] = 0.5 \times 2 = 1 \text{ M}$$

$$[\text{H}_3\text{O}^+] = 10^{-14} \div 1 = 10^{-14} \text{ M}$$

$$\text{pH} = -\log 10^{-14}$$

$$= 14$$

Question 8

Answer: B

Explanation

An oxidant undergoes reduction. In reduction, electrons are gained so the oxidation number becomes more negative, thus decreasing.

Question 9

Answer: C

Explanation

The products of this reaction are lithium chloride, water and carbon dioxide. Carbon dioxide reacts with limewater producing a product that turns it cloudy.

Question 10

Answer: C

Explanation

This question requires consultation with the electrochemical series. Due to the arrangement on the series of copper ion and iron solid (a top left to bottom right arrangement), this is the only plausible answer.

Question 11

Answer: C

Explanation

Options A, B and D all contribute to a rise in atmospheric carbon dioxide; which is a greenhouse gas.

Question 12

Answer: B

Explanation

Using hydrochloric acid in cleaning does not directly contribute to the problem as it is used in solution and thus, less likely to be present in the atmosphere to dissolve in rain.

Question 13

Answer: D

Explanation

Precipitation is the return of liquid water to the ground by rain.

Question 14

Answer: A

Explanation

The high solubility of water is mainly due to its polar nature. Options B, C and D are properties all directly related to the strong hydrogen bonds found between water molecules.

Question 15

Answer: A

Explanation

$$\begin{aligned} \% \text{ AE} &= \frac{2\text{NO}}{3\text{Cu} + 8\text{HNO}_3} \times 100 \\ &= \frac{2 \times (14 + 16)}{\quad} \times 100 \end{aligned}$$

$$(3 \times 63.5) + 8 \times (1 + 14 + 48)$$

$$= \frac{60}{694.5} \times 100$$

$$= 9\%$$

Question 16*Answer: B**Explanation*

$$n(\text{Cu}) = 11 \div 63.5 = 0.17 \text{ mol}$$

2:3 ratio, therefore $n(\text{NO}) = n(\text{Cu}) \times 2/3$

$$n(\text{NO}) = 0.115 \text{ mol}$$

$$V(\text{NO}) = 0.115 \times V_m$$

$$V(\text{NO}) = 0.115 \times 24.5$$

$$= 2.8 \text{ L}$$

Question 17*Answer: C**Explanation*Using $P_1V_1 = P_2V_2$

Converted 0.7 atm to kPa = 70.91 kPa

$$700 \times 25 = 70.91 \times V_2$$

$$= 246.8 \text{ mL}$$

$$700 - 246.8 = 453.2 \text{ mL}$$

Question 18*Answer: B**Explanation*

Calculate the number of mole of each of the options. As they would all be multiplied by the same value to get the volume at STP, the mole value can be used as a comparison.

$$\text{In option B, } n(\text{CO}_2) = 9.03 \times 10^{22} \div 6.02 \times 10^{23}$$

$$= 0.15 \text{ mol}$$

$$\text{Option C generates a smaller value: } n(\text{O}_2) = 2.88 \div 32 = 0.09 \text{ mol}$$

Question 19*Answer: A**Explanation*Using $\frac{V_1}{T_1} = \frac{V_2}{T_2}$

$$T_1 = T_2$$

$$\frac{7.3}{293} = \frac{x}{270}$$

$$293 \quad 270 \quad \Rightarrow x = 6.7 \text{ L}$$

Question 20*Answer: A**Explanation*

$$n(\text{CH}_4) = 2\text{g} \div 16\text{g mol}^{-1} = 0.125 \text{ mol}$$

From the combustion of methane, two products are formed: carbon dioxide and water.

For every 1 mole of methane combusted, 1 mole of carbon dioxide and 2 mole of water is formed. Thus, for 0.125 mol of methane, 0.125 mol of carbon dioxide and 0.25 mol of water is formed = 0.375 mol in total of products.

SECTION B: Short-answer questions

* = 1 mark throughout the paper

Question 1

- a. 10.5g / 100g water (from the data table)
*10.5 x 0.75 = 7.9 g
- b. 4.95g / 100g water (from the data table)
*4.95 x 2.5 = 12.375g/250g of water to be saturated
11.1 g is less than this so it is *unsaturated/ not saturated.
- c. 1/2*at 100°C - 34.4g/100g water = 17.2g in 50 mL
1/2*at 25 °C – 10.5g/100g water = 5.25g in 50 mL
*17.2 – 5.25 = 11.95 g will crystallise out
- d. *The ethanol dissolves in water by making hydrogen bonds with water as both molecules are polar. *Barium nitrate, being ionic, dissolves by making ion-dipole attractions with the water molecules

Question 2

- a. * $\text{H}_2\text{CO}_3(\text{aq}) + \text{H}_2\text{O}(\text{l}) \leftrightarrow \text{HCO}_3^-(\text{aq}) + \text{H}_3\text{O}^+(\text{aq})$
 * $\text{HCO}_3^-(\text{aq}) + \text{H}_2\text{O}(\text{l}) \leftrightarrow \text{CO}_3^{2-}(\text{aq}) + \text{H}_3\text{O}^+(\text{aq})$
- b. * $\text{Zn}(\text{s}) + 2\text{HCl}(\text{aq}) \rightarrow \text{ZnCl}_2(\text{aq}) + \text{H}_2(\text{g})$
- c. The acid is diprotic, so it can donate two protons*. However the second stage of ionization is not complete so it is difficult to know the $[\text{H}^+]$ *
- d. * $[\text{H}^+] = 10^{-12.6} \text{ M} = 2.5 \times 10^{-13} \text{ M}$
 * $[\text{OH}^-] = 10^{-14} / 10^{-12.6} = 0.04 \text{ M}$
- e. * $10^3 = 1000$ times more acidic

Question 3

- a. * $\text{LiOH}(\text{aq}) + \text{HNO}_3(\text{aq}) \rightarrow \text{LiNO}_3(\text{aq}) + \text{H}_2\text{O}(\text{l})$
- b. * $n(\text{LiOH}) = 0.25 \times 0.05$
 $= 0.0125 \text{ mol}$
- * $n(\text{HNO}_3) = 1 \times n(\text{LiOH}) = 0.0125 \text{ mol}$
 $V(\text{HNO}_3) = 0.08 \text{ L}$
 $c(\text{HNO}_3) = 0.0125 \text{ mol} \div 0.08 \text{ L} = * 0.16 \text{ M}$
- c. i. * $n(\text{LiOH}) = 0.0125 \text{ mol}$ * $n(\text{H}_2\text{SO}_4) = 0.3 \text{ mol L}^{-1} \times 0.12 \text{ L}$
 $= 0.036 \text{ mol}$

$n(\text{LiOH}) : n(\text{H}_2\text{SO}_4)$ is 2:1 therefore 0.00625 mol of H_2SO_4 would react completely with 0.0125 mol of LiOH and 0.018 mol of LiOH would be needed to react completely with 0.036 mol of H_2SO_4

* LiOH is the limiting reactant

- ii. * $n(\text{H}_2\text{O}) = n(\text{LiOH}) = 0.0125 \text{ mol}$
 $m(\text{H}_2\text{O}) = 0.0125 \text{ mol} \times 18 \text{ g mol}^{-1} = * 0.225 \text{ g}$

Question 4

a. $*n(\text{glucose}) = 7.5 \times 10^{23} / 6.02 \times 10^{23} = 1.246 \text{ mol}$
 $c = n/V = 1.246/0.1 = *12.5 \text{ M}$

b. $200 \times 1.5 = 0.9 \times V_2$

$*V_2 = 333.33 \text{ mL}$

$*V_{\text{added}} = V_2 - V_1 = 333\text{mL} - 200\text{mL} = 133 \text{ mL}$

Question 5

a. $\frac{P_1 V_1}{T_1} = \frac{P_2 V_2}{T_2}$

b. $\frac{1.8 \times 8}{298} = \frac{1.97x}{308}$

*for pressure unit change

*Kelvin unit

$= *7.5 \text{ L}$

c. Using $V = \frac{nRT}{P}$

$*n(\text{O}_2) = 50\text{g} \div 32\text{gmol}^{-1} = 1.56 \text{ mol}$

$V = \frac{1.56 \times 8.31 \times 303}{354.55}$

*for unit conversions

$V = *11 \text{ L}$

- d. i. There is empty space between gas particles so the particles can be pushed closer together
- ii. The forces between gas particles are negligible, therefore particles will move randomly and independently to fill up a given space.

Question 6

a.

Property	Explanation in terms of structure and bonding	Importance in sustaining life
A very good solvent	*Water is polar and so can dissolve many substances because of electrostatic forces of attraction	*Nutrients can be transported throughout living things
Less dense as a solid than a liquid	*As a solid, water forms a hexagonal lattice which has pockets of empty space	*ice floats; insulating the liquid water underneath at a constant temperature
High Specific Heat Capacity	*strong hydrogen bonds between water molecules require more energy to be absorbed before a change in temperature is observed	*more stable water temperatures for aquatic life, less evaporation from reservoirs

b. (various answers) * barium nitrate and * sodium sulphate

Question 7

a. i.

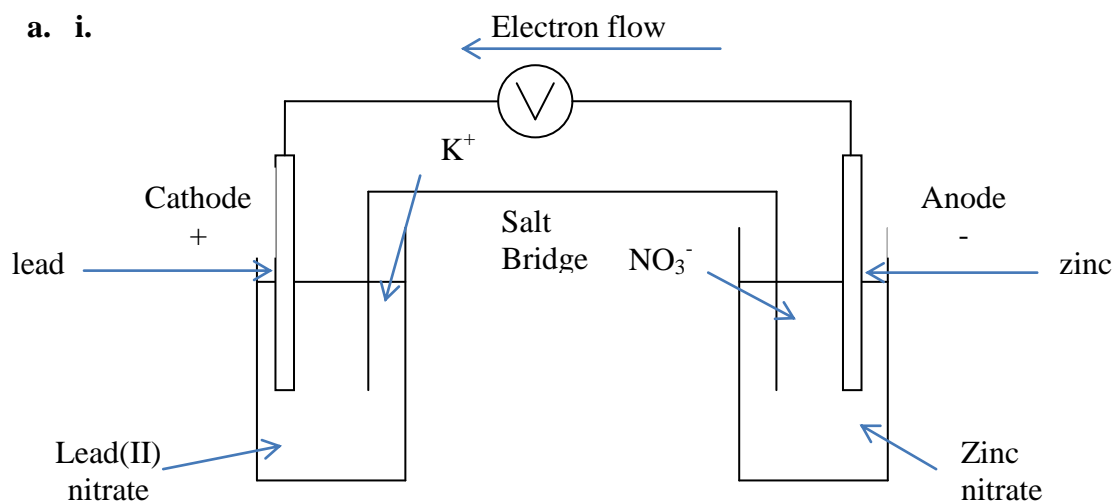

- the materials used for the electrodes *
- the polarity of the electrodes *
- the direction of electron flow *
- the solutions to be used *
- the direction of flow of the ions in the salt bridge. *

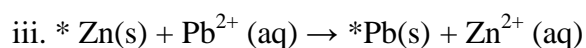
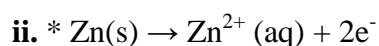

- b. i.** Overall charge $\text{SO}_4^{2-} = -2$
Oxygen provides $4 \times -2 = -8$
Sulphur provides the difference $= +6$ *
- ii.** Overall charge $= 0$
Hydrogen provides $4 \times +1 = +4$
Nitrogen has to provide -4
Since there are 2 nitrogen atoms each provides $-4 \div 2 = -2$ *