

2012 Trial Examination

STUDENT NUMBER

Figures

Words

Letter

--

CHEMISTRY

Unit 1 – Written examination 1

Reading time: 15 minutes

Writing time: 1 hour and 30 minutes

QUESTION & ANSWER BOOK

Structure of book

<i>Section</i>	<i>Number of questions</i>	<i>Number of questions to be answered</i>	<i>Number of marks</i>
A	20	20	20
B	6	6	62
			Total 82

- Students are permitted to bring into the examination room: pens, pencils, highlighters, erasers, sharpeners and rulers and one scientific calculator.
- Students are NOT permitted to bring into the examination room: blank sheets of paper and/or white out liquid/tape.

Materials supplied

- Question and answer book of 15 pages.

Instructions

- Print your name in the space provided on the top of this page.
- All written responses must be in English.

Students are NOT permitted to bring mobile phones and/or any other unauthorised electronic devices into the examination room.

SECTION A – Multiple-choice questions**Instructions for Section A**

Answer **all** questions.

Choose the response that is **correct** for the question.

A correct answer scores 1, an incorrect answer scores 0.

Marks are **not** deducted for incorrect answers.

If more than 1 answer is completed for any question, no mark will be given.

Question 1

There are many discoveries that have contributed to our current understanding of atomic theory. Four of these discoveries are;

radioactivity isotopes nanotechnology electrons

Which of the following lists these discoveries in chronological order? (Earliest to most recent)

- A. radioactivity isotopes nanotechnology electrons
 B. isotopes nanotechnology electrons radioactivity
 C. electrons radioactivity isotopes nanotechnology
 D. isotopes electrons radioactivity nanotechnology

Question 2

An ion has the electron configuration of $1s^2 2s^2 2p^6 3s^2 3p^6$. The ion is

- A. Ne^-
 B. Cl^+
 C. Ar^-
 D. Ca^{2+}

Question 3

The graph below refers to the elements in Period 3 of the Periodic Table (argon excepted).

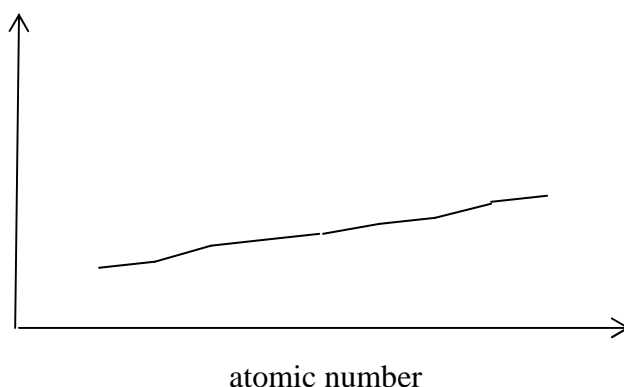

The vertical axis of the graph is most likely to refer to

- A. electronegativity
 B. melting point
 C. metallic nature
 D. electrical conductivity

SECTION A - continued

Question 4

A sample of substance Z was analysed and found to have a high melting point and no electrical conductivity as a solid. The substance was soluble in water and the solution formed does conduct electricity. The type of bonding in substance Z is most likely to be

- A. metallic
- B. covalent molecular
- C. covalent network
- D. ionic

Questions 5 and 6 refer to the following information

The symbol Z stands for one of the elements of the Periodic Table. The chemical formula for lithium chlorate is LiClO_3 . Element Z forms the compound, $\text{Z}_2(\text{SO}_4)_3$.

Question 5

The chemical formula for the compound formed between Z and chlorate ions will be

- A. ZClO_3
- B. $\text{Z}(\text{ClO}_3)_2$
- C. $\text{Z}(\text{ClO}_3)_3$
- D. $\text{Z}_2(\text{ClO}_3)_3$

Question 6

The identity of element Z could be

- A. sodium
- B. fluorine
- C. magnesium
- D. aluminium

Question 7

Which of the following contains the most atoms?

- A. 0.1 mol of CuSO_4
- B. 0.2 mol of CuS
- C. 0.3 mol of sodium metal
- D. 0.4 mol of copper metal

Question 8

Methane, CH_4 has a low melting point because

- A. all bonds in methane are weak
- B. the bonds between neighbouring molecules are weak
- C. the bonds within each molecule are weak
- D. it contains covalent bonds and they are weak bonds

SECTION A – continued

TURN OVER

Questions 9 and 10 refer to the following information

A hydrocarbon can be formed when 7.2 g of carbon reacts with 1.6 g of hydrogen

Question 9

The empirical formula for the hydrocarbon is

- A. CH
- B. CH₂
- C. C₂H₅
- D. C₃H₈

Question 10

The molecule in question could be

- A. ethene
- B. propane
- C. butane
- D. pentene

Question 11

The structure and shape of a molecule is shown

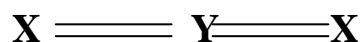

The molecule is most likely to be

- A. H₂O
- B. CO₂
- C. NH₃
- D. SiO₂

Question 12

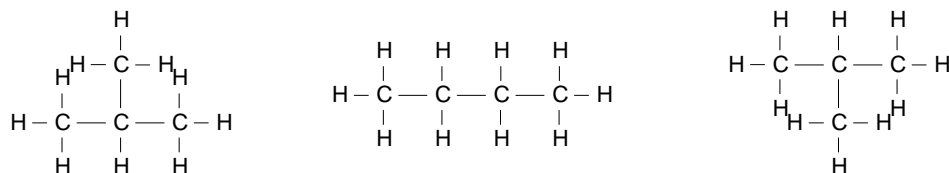

The diagram above shows

- A. two different isotopes of butane
- B. three different isotopes of butane
- C. isomers of propane and butane
- D. a homologous series

SECTION A - continued

Question 13

Equal masses of the three compounds shown are added to three separate containers.

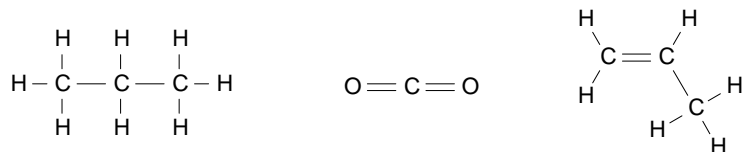

- A. There will be an equal number of mole of all three compounds
- B. There will be an equal number of mole of carbon dioxide and propane but more propene
- C. There will be an equal number of mole of propane and propene but more carbon dioxide
- D. There will be a different number of mole of all three compounds

Question 14

Which of the following lists contains only alkenes?

- A. C_3H_8 , C_5H_{10} , C_8H_{16}
- B. C_2H_4 , C_8H_{16} , $\text{C}_{12}\text{H}_{26}$
- C. C_3H_6 , C_5H_{10} , $\text{C}_{12}\text{H}_{24}$
- D. CH_4 , C_5H_{10} , C_8H_{16}

Question 15

The percentage mass of carbon in an alkene is compared to that of the corresponding alkane. The percentage mass of carbon in the alkene will be

- A. less than that of the alkane
- B. equal to that of the alkane
- C. greater than that of the alkane
- D. vary with the particular alkene in question

Question 16

A paper clip can float on the surface of the water in a beaker. This is because

- A. of the strong surface tension between the water molecules
- B. of the strong surface tension between the metal and the water
- C. the density of the metal is lower than that of the water
- D. water and the metal both have strong dipoles

SECTION A – continued
TURN OVER

Question 17

The model of a substance shown in the diagram could be a model of

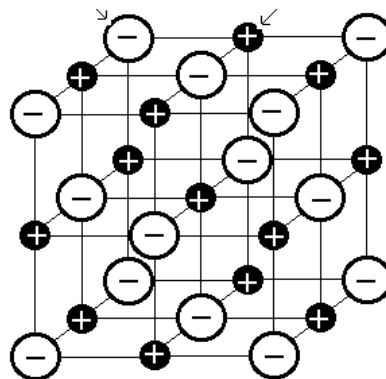

- A. silica dioxide, SiO_2
- B. sodium chloride, NaCl
- C. dry ice, CO_2
- D. a typical metal like sodium

Question 18

A flask contains 1.8×10^{24} molecules of oxygen gas, O_2 . This is close to

- A. 0.3 mole of oxygen molecules
- B. 3 mole of oxygen molecules
- C. 3 mole of oxygen atoms
- D. 3×10^{23} mole of oxygen atoms

Question 19

Hydrogen peroxide has a formula of H_2O_2 . The number of lone pairs of electrons in this molecule will be

- A. 0
- B. 2
- C. 3
- D. 4

Question 20

The following ions O^{2-} , F^- , Na^+ and Mg^{2+}

- A. all have the same number of electrons
- B. all have the same atomic number
- C. lead to significant peaks on a mass spectrum
- D. belong to the same Period of the Periodic Table

END OF SECTION A

SECTION B – Short answer questions**Instructions for Section B**

Answer **all** questions in the spaces provided.

To obtain full marks for your responses you should

- Give simplified answers with an appropriate number of significant figures to all numerical questions; unsimplified answers will not be given full marks.
- Show all working in your answers to numerical questions. No credit will be given for an incorrect answer unless it is accompanied by details of the working.
- Make sure chemical equations are balanced and that the formulas for individual substances include an indication of state; for example, $\text{H}_2(g)$; $\text{NaCl}(s)$

Question 1

The modern view of an atom has evolved over many centuries. Bit by bit, scientists have uncovered details of the particles present and their properties and role in the atom. The following questions relate to different aspects of the development of atomic theory.

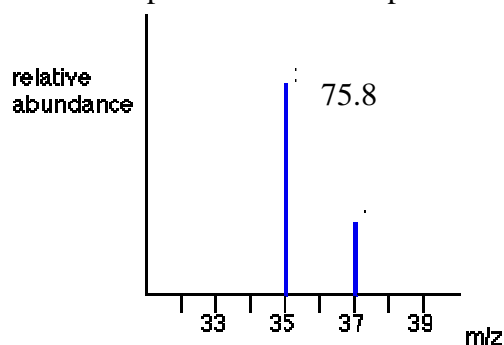

- a.
- The mass spectrum for chlorine shows two peaks. What is the explanation for an element having two separate peaks on a mass spectrum?

- What is the likely charge on the ions that are responsible for the peaks?

- Represent both peaks using the standard notation ${}^A_Z\text{X}$

SECTION B – Question 1 – continued
TURN OVER

- iv. Use the information on the spectrum to calculate the relative atomic mass of chlorine.

1 + 1 + 2 + 2 = 6 marks

b.

Electrons have been found to be moving around the nucleus of an atom. They have a negative charge and they move in pathways called orbits.

- i. How many electrons does the element titanium have?

-
- ii. How many shells of a titanium atom (in its ground state) contain electrons?

-
- iii. How many subshells of a titanium atom contain electrons?

-
- iv. How many orbitals of a titanium atom contain electrons?

1 + 1 + 1 + 1 = 4 marks

- c. The invention of the battery in the 18th century was soon harnessed by English scientist Sir Humphry Davy. He ran an electric current through a molten solution of potassium hydroxide. A silver material was found on the negative electrode. What was the material and explain the significance to the Periodic Table development of this discovery?

2 marks

SECTION B – Question 1 - continued

- d. When English scientist Henry Cavendish removed the oxygen from air and then the nitrogen from air, he found there was still some gas left. The gas was colourless and very unreactive so he was not able to identify the gas. What was the significance to the Periodic Table development of this discovery?

2 marks

Total 14 marks

Question 2

- a. Write the chemical formulas for the following compounds;

i. barium chloride

ii. copper (II) nitrate

iii. aluminium sulfate

1 + 1 + 1 = 3 marks

- b. Name the following compounds

i. $\text{Mg}(\text{OH})_2$ _____

ii. CuS _____

iii. $\text{Al}(\text{NO}_3)_3$ _____

1 + 1 + 1 = 3 marks

- c. Draw structural diagrams for the following compounds

i. 1-butanol

ii. 2-pentene

SECTION B - Question 2 - continued
TURN OVER

iii. 2,3-dimethylhexane

1 + 1 + 1 = 3 marks

Total 9 marks

Question 3

Two watchglasses and their contents are shown in the photo below.



Watchglass A: 0.50 mole of sulphur		Watchglass B: 0.50 mole of CuSO ₄	
number of mole of substance	equals	number of mole of substance	T / F
number of mole of atoms	equals	number of mole of atoms	T / F
number of atoms	equals	number of atoms	T / F
number of mole of sulfur atoms	equals	number of mole of sulfur atoms	T / F
number of mole of sulfur atoms	equals	number of mole of oxygen atoms	T / F
number of mole of sulfur atoms	equals	number of mole of sulfate ions	T / F

a. Circle T (true) or F (false) for each of the statements in the table that compare the contents of watchglass A with those of watchglass B

6 marks

b.

i. Calculate the percentage mass of sulfur in the copper sulfate sample.

SECTION B - Question 3 - continued

- ii. Will the percentage mass of sulfur be the same in a 1.0 mole sample of copper sulfate? **Explain** your answer.

2 + 1 = 3 marks

- c. A 1.50 kg bag of garden fertilizer contains 1.2 % copper sulfate by mass.

- i. Calculate the mass of copper sulfate in the bag.

- ii. Calculate the mass of sulfur in the bag, assuming CuSO_4 is the only source of sulfur.

2 + 2 = 4 marks

Total 13 marks

Question 4

An electron dot diagram of an atom of nitrogen and an atom of hydrogen are shown below.



nitrogen
electronegativity 3.0



hydrogen
electronegativity 2.1

A compound can be formed from the reaction between nitrogen gas and hydrogen gas. The compound is called ammonia.

- a. Draw an electron dot diagram of an ammonia molecule

1 mark

SECTION B - Question 4 - continued
TURN OVER

b. What shape will this molecule be?

_____ 1 mark

c. Draw in any likely dipoles on this molecule

_____ 1 mark

d. Will this molecule be polar? Explain your answer.

_____ 2 marks
Total 5 marks

Question 5

a. A list of compounds that you have studied this semester is provided below

Cu CH₄ CuSO₄ HCl diamond NaCl chalk

Select a compound from this list that matches the properties given in each question. Justify your selection in each case.

i. A blue powder is found to have a melting point in excess of 1000 °C. It dissolves in water to form a solution that conducts electricity.

compound _____

justification _____

ii. A clear liquid is a non-conductor of electricity. It dissolves in water to form a solution that conducts electricity

compound _____

justification _____

iii. This material forms a very crystalline solid. It does not conduct electricity and it is very hard. It is heated to 2000 °C but it does not melt.

compound _____

justification _____

2 + 2 + 2 = 6 marks

SECTION B - Question 5 - continued

b. Give the accepted chemical name for the following compounds

i.

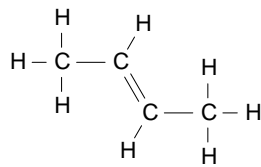

ii.

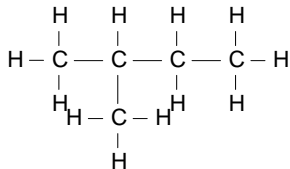

1 + 1 = 2 marks

c. A nanotube is 688 nm in length. How long is this in metres? _____

1 mark

d. A drop of water is placed gently onto a glass plate and another drop is placed on a piece of polyethene plastic. The drops are shown in the diagram



i. The glass is described as a _____ surface while the polyethene is _____

ii. Explain carefully why the drop assumes a different shape on the glass than it does on the polyethene.

2 + 2 = 4 marks

Total 13 marks

SECTION B - continued
TURN OVER

Question 6

Polymers are long molecules containing repeating units. The polymers form when monomers react together to form a long molecule.

a. One of the most common monomers used in society is ethene.

i. Draw a structural diagram of an ethene molecule

ii. If 5 ethene molecules and 1 hydrogen molecule react together, a molecule of decane can be formed that has a backbone containing 10 carbon atoms in a row.

Is the molecule formed a polymer? Explain your answer.

iii. There are two common forms of polyethene, high density polyethene, HDPE and low density polyethene, LDPE. Explain how the structure of these two forms of polyethene differs.

1 + 1 + 2 = 4 marks

b. Draw the monomer that is used to form the polymer shown below

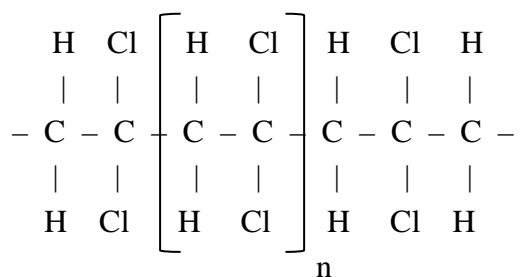

1 mark

SECTION B - Question 6 - continued

c. The handles of a saucepan are usually made from thermoset polymers.

i. What does thermoset mean?

ii. Many polymer items are recyclable. The polymer is heated to a liquid and allowed to set in a different mould leading to a new product. What will happen if you heat a thermoset polymer in an attempt to melt it and to remould it as a different product?

1 + 2 = 3 marks

Total 8 marks

END OF QUESTION AND ANSWER BOOK