

Trial Examination 2010

VCE Chemistry Unit 4

Written Examination

Question and Answer Booklet

Reading time: 15 minutes
Writing time: 1 hour 30 minutes

Student's Name: _____

Teacher's Name: _____

Structure of Booklet

Section	Number of questions	Number of questions to be answered	Marks
A Multiple-choice	20	20	20
B Short-answer	6	6	55
			Total 75

Students are permitted to bring into the examination room: pens, pencils, highlighters, erasers, sharpeners and one scientific calculator.

Students are NOT permitted to bring into the examination room: blank sheets of paper and/or white out liquid/tape.

Materials supplied

Question and answer booklet of 17 pages.

Data booklet of 11 pages.

Answer sheet for multiple-choice questions.

Instructions

Please ensure that you write **your name** and your **teacher's name** in the space provided on this booklet and in the space provided on the answer sheet for multiple-choice questions.

All written responses must be in English.

At the end of the examination

Place the answer sheet for multiple-choice questions inside the front cover of this booklet and hand them in.

Students are NOT permitted to bring mobile phones and/or any other unauthorised electronic devices into the examination room.

Students are advised that this is a trial examination only and cannot in any way guarantee the content or the format of the 2010 VCE Chemistry Unit 4 Written Examination.

SECTION A: MULTIPLE-CHOICE QUESTIONS**Instructions for Section A**

Answer **all** questions in pencil on the answer sheet provided for multiple-choice questions. Choose the response that is **correct** or that **best answers** the question. A correct answer scores 1, an incorrect answer scores 0. Marks will **not** be deducted for incorrect answers. No mark will be given if more than one answer is completed for any question.

Question 1

In a calorimetry experiment, 50.0 mL of 0.350 M $\text{Fe}^{3+}(\text{aq})$ was mixed with 50.0 mL of 0.150 M $\text{Sn}^{2+}(\text{aq})$. The following chemical reaction occurred:

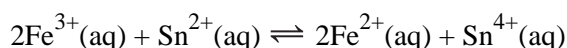

The temperature rose by 0.730°C.

Given that the calorimeter constant is 476 J° C⁻¹, the magnitude of the heat of reaction (in kJ mol⁻¹) is

- A. 19.9
- B. 39.8
- C. 46.3
- D. 92.6

Question 2

Cresol red is a weak acid (HCR) that acts as an acid-base indicator. Its ionisation constant, K_a , has a value of 5.0×10^{-9} . At low pH, the indicator is present mainly as the acid form (HCR) which is yellow in colour. At high pH, it exists mainly in its base form (CR^-) which is red in colour. When the two forms are in equal concentrations, or differ in concentration by a factor of between 0.1 and 10, the solution containing the indicator appears orange in colour.

The expected colour of the indicator in water at 25°C would be

- A. red.
- B. orange.
- C. yellow.
- D. known only by observation and cannot be determined from the data provided.

Question 3

In which of the following is the major energy source converted directly to electrical energy?

- A. nuclear power plant
- B. photovoltaic cell
- C. petrol driven generator
- D. hydroelectric power station

Question 4

The acid ionisation constant, K_a , of the HSO_4^- ion is 9.9×10^{-3} .

If 0.010 mol of NaHSO_4 is dissolved in 100.0 mL of water, the pH of the resulting solution is

- A. 1.5
- B. 2.4
- C. 3.0
- D. 3.7

Question 5

A water bath to be used in the study of reactions at body temperature (37°C) is prepared by mixing hot tap water (75°C) with 80.0 g of cold water (19°C).

The mass of hot water which must be added to the cold water to achieve the required water bath temperature is closest to

- A. 20 g
- B. 30 g
- C. 40 g
- D. 50 g

Question 6

Some of the brown coloured gas NO_2 is placed in a sealed container and reaches equilibrium with the colourless dimer N_2O_4 according to the equation:

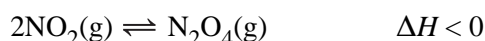

Consider the results, if the following changes are made to the reaction conditions.

- I. Nitrogen gas is added at constant volume
- II. The volume of the container is decreased at constant temperature
- III. The gas container is cooled at constant volume

Which of the above changes to the reaction conditions would produce an equilibrium mixture that is lighter in colour?

- A. I and II only
- B. II and III only
- C. I and III only
- D. III only

Question 7

Hydrochloric acid of pH 1 is added to 20 mL of 0.1 M sodium hydroxide solution, resulting in a solution of pH 4.

The volume of the hydrochloric acid used is closest to

- A. 20 mL
- B. 30 mL
- C. 40 mL
- D. 50 mL

Question 8

Consider this energy profile for a particular reaction.

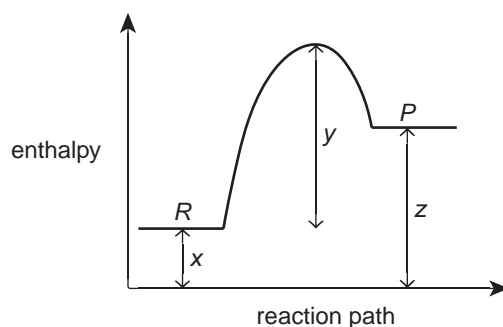

Which of the following is an incorrect conclusion from the data presented?

- A. It takes more energy to break the bonds in the reactants than the energy released when the products form.
- B. The activation energy of the reverse reaction is $x + y$.
- C. The magnitude of the heat of reaction is equal to $z - x$.
- D. When the products form, after bonds in the reactants are broken, energy equivalent to $x + y - z$ is released.

Question 9

Water undergoes self-ionisation according to the equation:

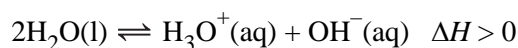

When a beaker of distilled water is heated from 25°C to 65°C , the water

- A. becomes alkaline as the pH increases.
- B. remains neutral as the pH increases.
- C. becomes acidic as the pH decreases.
- D. remains neutral as the pH decreases.

Question 10

The diagram below shows the distribution of energies of particles at a particular temperature.

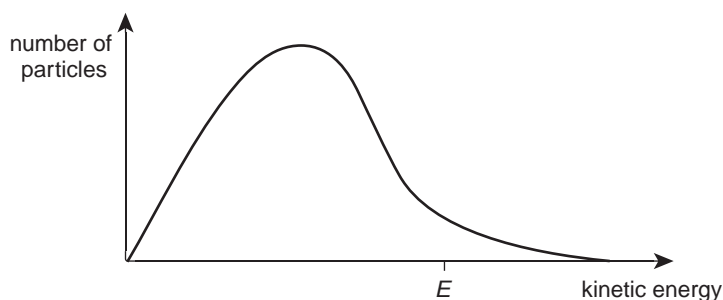

Which of the following shows the changes that will occur if the temperature is decreased?

	Total kinetic energy of the particles	Area under the curve	Proportion of particles with more energy than E
A.	unchanged	decreased	decreased
B.	decreased	unchanged	increased
C.	unchanged	increased	unchanged
D.	decreased	unchanged	decreased

Question 11

The gases X, Y and Z were placed in a sealed container and allowed to come to equilibrium as shown by the following equation.

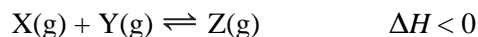

An experiment was conducted with the gaseous equilibrium at 80°C. Concentrations of the gases over time are depicted in the graph below.

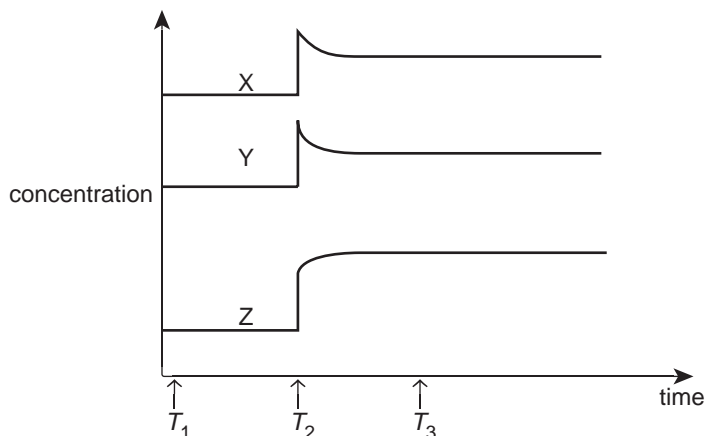

Four statements concerning the results are:

- I. Successful collisions between gas particles are occurring at T_3 .
- II. Immediately after T_2 , the rate of the forward reaction exceeds the rate of the reverse reaction.
- III. The change at T_2 could be caused by heating the container or by adding an equimolar mixture of X, Y and Z.
- IV. The value of the equilibrium constant at T_1 is different from that at T_3 .

Which of the statements above are consistent with the experimental results depicted in the graph?

- A. I and II only
- B. II and III only
- C. II, III and IV only
- D. III and IV only

Question 12

The first commercially available dry cell used these two half reactions:

- I. $\text{Zn}^{2+}(\text{aq}) + 2\text{e}^- \rightleftharpoons \text{Zn}(\text{s})$
- II. $2\text{MnO}_2(\text{s}) + 2\text{NH}_4^+(\text{aq}) + 2\text{e}^- \rightleftharpoons \text{Mn}_2\text{O}_3(\text{s}) + 2\text{NH}_3(\text{aq}) + \text{H}_2\text{O}(\text{l}) \quad E^0 = +0.74\text{V}$

Which of the following occurs when the cell generates electricity?

- A. At the negative electrode, manganese changes in oxidation state from +4 to +6.
- B. Zinc ions are produced at the cathode.
- C. Water is consumed at the positive electrode.
- D. The mass of zinc decreases at the anode.

Question 13

The catalysed reaction of benzene with chlorine is exothermic, and occurs by a two-step reaction process. The first step is endothermic and has a high activation energy. It produces an intermediate known as a carbocation. The reaction of this carbocation in the second exothermic step has a much lower activation energy. The reaction may be represented by the reaction sequence:

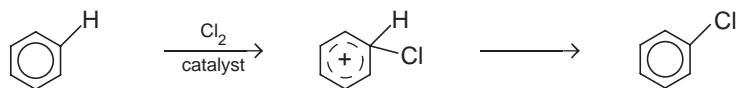

Which of the energy profiles shown below best represents the energy changes occurring during the benzene/chlorine reaction?

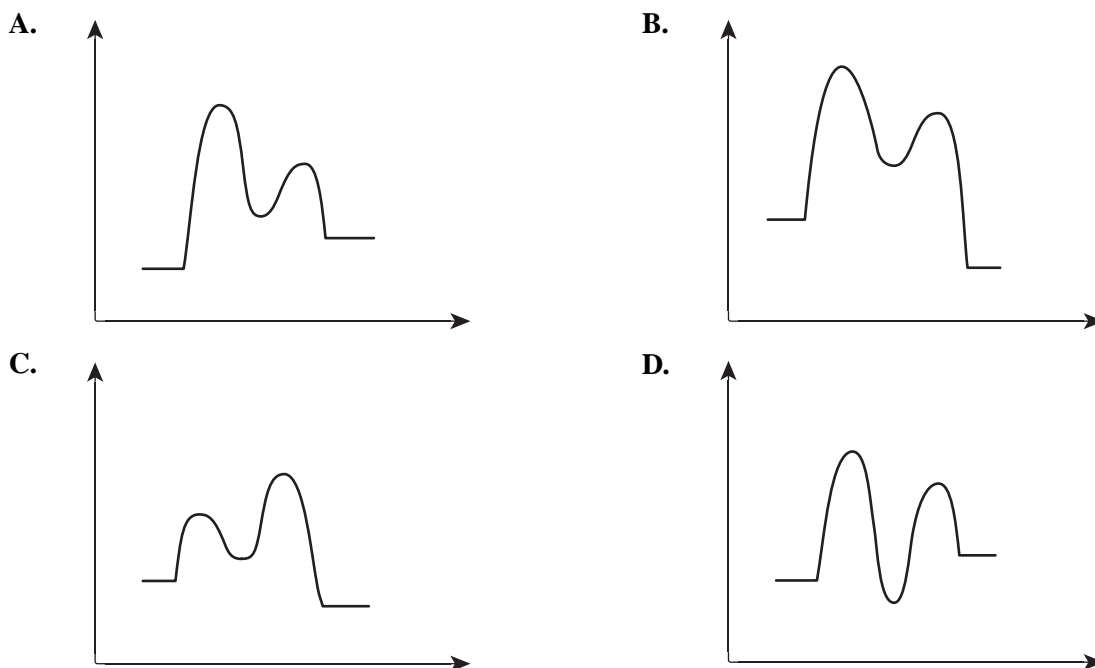
**Question 14**

The following reaction is used in a number of experiments investigating galvanic cells:

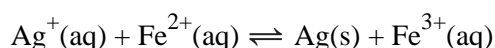

A disc of silver is used as one electrode and a carbon rod is used as the other electrode. When various concentrations of ions were used in the galvanic cell, the following results were recorded.

Experiment	[Fe ³⁺]	[Fe ²⁺]	[Ag ⁺]	Anode	Cell EMF
1	1 M	1 M	1 M	carbon rod	0.03 V
2	0.001 M	0.10 M	0.10 M	carbon rod	0.09 V
3	0.10 M	0.001 M	0.001 M	silver disc	0.27 V
4	0.00033 M	0.01 M	0.01 M	neither carbon nor silver	0.0V

In experiment 4, the anode could not be identified because

- A. all the reactants had been consumed, leading to the cell not producing any voltage.
- B. both the oxidation and reduction reactions had ceased, resulting in zero voltage in the cell.
- C. the cell reaction had reached equilibrium, yielding no net reaction in the cell.
- D. the products in the cell had built up to an extent which hindered the operation of the cell.

Question 15

Consider the equilibrium shown in the equation;



A reaction mixture at equilibrium is heated. Which of the following shows the possible changes occurring as a result of the heating?

	Amount of H_2	Amount of NH_3
A.	increase by 0.243 mol	decrease by 0.162 mol
B.	increase by 0.189 mol	decrease by 0.284 mol
C.	decrease by 0.143 mol	increase by 0.095 mol
D.	decrease by 0.155 mol	increase by 0.155 mol

Question 16

The following reactions occur spontaneously:

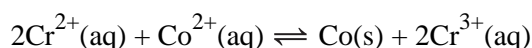
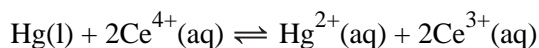
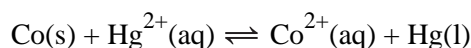

Using the information provided, which of the following pairs of reactants would be expected to react spontaneously?

- A. $\text{Co}(\text{s})$ and $\text{Ce}^{3+}(\text{aq})$
- B. $\text{Cr}^{3+}(\text{aq})$ and $\text{Hg}(\text{l})$
- C. $\text{Co}^{2+}(\text{aq})$ and $\text{Ce}^{4+}(\text{aq})$
- D. $\text{Hg}^{2+}(\text{aq})$ and $\text{Cr}^{2+}(\text{aq})$

Question 17

Consider the complete combustion of the two biochemical fuels, methane and ethanol.

Which of the following correctly identifies the comparative features of the fuels?

	Fuel with the larger energy density (kJ g^{-1})	Fuel producing least energy for each mole of CO_2 produced
A.	methane	methane
B.	methane	ethanol
C.	ethanol	methane
D.	ethanol	ethanol

Questions 18 and 19 refer to the following information.

A galvanic cell was constructed as shown below. Half-cell I contained 100.0 mL of a 1.00 M solution of copper(II) ion, with a copper electrode. Half-cell II contained 100.0 mL of a 1.00 M solution of X^{2+} ion, along with its redox conjugate, X^n . When the cell had operated for some time it was found that the change in mass at the copper electrode was 1.11 g, while the concentration of the X^{2+} ion in half-cell II decreased to 0.65 M. There was no change in the mass of the electrode in half-cell II. The volume of solution in both half-cells remained constant.

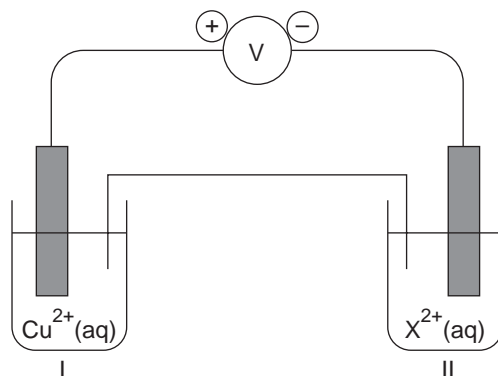

Question 18

Which of the following shows the ratio of numbers of Cu atoms to X^{2+} ions reacting during the operation of the cell?

- A. 1:1
- B. 1:2
- C. 2:1
- D. 1:4

Question 19

Based on the experimental data provided, the value of n in the redox conjugate X^n is

- A. 0
- B. +1
- C. +3
- D. +4

Question 20

Hydrogen bromide gas was introduced into an empty, sealed reaction vessel and heated to a fixed temperature to establish the following equilibrium:

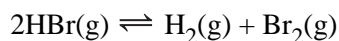

At equilibrium, the 4.0 L vessel contained 2.0 mol Br_2 , 1.25 mol H_2 and 0.50 mol HBr .

The equilibrium constant at the fixed temperature for the reverse reaction is

- A. 0.10
- B. 0.20
- C. 5.0
- D. 10

SECTION B: SHORT-ANSWER QUESTIONS**Instructions for Section B**

Answer **all** questions in the spaces provided.

To obtain full marks for your responses you should

- give simplified answers with an appropriate number of significant figures to all numerical questions; unsimplified answers will not be given full marks.
- show all working in your answers to numerical questions. No credit will be given for an incorrect answer unless it is accompanied by details of the working.
- make sure chemical equations are balanced and that the formulas for individual substances include an indication of state, for example $\text{H}_2(\text{g})$; $\text{NaCl}(\text{s})$.

Question 1

Victoria has vast reserves of brown coal, used to generate electricity in coal-fired power stations. While coal is a cheap, high-energy fuel, it is non-renewable, and its combustion contributes to atmospheric carbon dioxide levels.

A proposed alternative to the burning of coal is to use it to produce a gaseous fuel by the process of coal gasification. In this process coal is treated with oxygen and steam at high temperatures to break many of the carbon-carbon bonds. These bonds are replaced by carbon-oxygen and carbon-hydrogen bonds as the coal fragments react. The product is a mixture of carbon monoxide and hydrogen called syngas, and methane. Each of these products can react with oxygen to release energy.

- a. Suggest one advantage of using coal for this production of gaseous fuel instead of burning it directly.

1 mark

- b. Syngas is used in the production of methanol, which may also be used as a fuel.

Write a thermochemical equation for the combustion of methanol.

2 marks

- c. Methanol produced in this way is a non-renewable energy source.

Write an equation for the production of a liquid fuel using a renewable energy source.

1 mark

- d. Combustion of methanol also adds to atmospheric carbon dioxide levels. The use of uranium-235 in a fission reaction produces energy without contributing to atmospheric carbon dioxide levels.

- i. What is the source of energy released when ^{235}U undergoes a fission reaction?

ii. State one further advantage (other than the non-emission of carbon dioxide) of the use of fission reactions as an energy source.

1 + 1 = 2 marks

Total 6 marks

Question 2

The Direct Methanol Fuel Cell (DMFC) uses proton exchange membrane technology. The solid polymer membrane acts as the electrolyte and separates the anode and cathode compartments. It is an excellent conductor of hydrogen ions but is also an electrical insulator. Methanol (CH_3OH) is used as the energy-dense, liquid fuel.

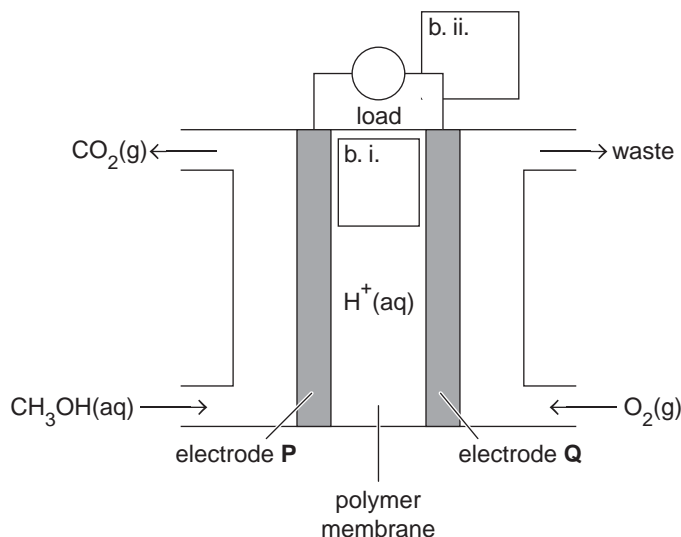

a. The overall fuel cell reaction is the same as the combustion reaction of methanol.

i. Write the half-equation for the oxidation process occurring in the fuel cell.

1 + 2 = 3 marks

b. i. In the space on the diagram, use an arrow to mark the direction of movement of the H^+ ion through the polymer membrane

ii. In the space on the diagram, use an arrow to mark the direction of electron flow in the external circuit.

iii. Which electrode (**P** or **Q**) is the cathode?

1 + 1 + 1 = 3 marks

c. The DMFC is more efficient when run at high temperatures and pressures, and yet the conditions most commonly used are 50°C to 120°C and atmospheric pressure.

Suggest a reason to explain the use of these lower temperatures and pressures.

1 mark

- d.** The cell uses an aqueous methanol solution.

Explain why pure methanol cannot be used in the operation of the cell.

1 mark

- e.** A platinum catalyst is used for the anode and cathode reactions. Some carbon monoxide (CO) is formed at the electrode **P** reaction. This compound strongly adsorbs onto the surface of the catalyst. Explain why this would have an effect on the performance of the DMFC.

1 mark

- f.** State one way in which a fuel cell, such as the DMFC, is different from a primary cell.

1 mark

Total 10 marks

Question 3

An experiment was conducted using the reaction of magnesium ribbon with excess 1.0 M hydrochloric acid at a fixed temperature. The volume of hydrogen gas produced was measured each minute for eight minutes and the results recorded.

Time (minutes)	0	1	2	4	3	5	6	7	8
Volume of H ₂ (g) (mL)	0	11.3	20.8	24.9	28.2	31.2	32.0	32.0	32.0

- a. Write a balanced equation for the chemical reaction which occurred.

1 mark

- b. Explain why the rate of reaction was highest in the 0 to 1 minute time interval.

2 marks

- c. Calculate the average rate of reaction for the complete reaction.

1 mark

- d. Calculate the mass of magnesium used in the experiment if the hydrogen gas was collected at SLC.

2 marks

- e. The results of the original experiment were sketched onto a grid:

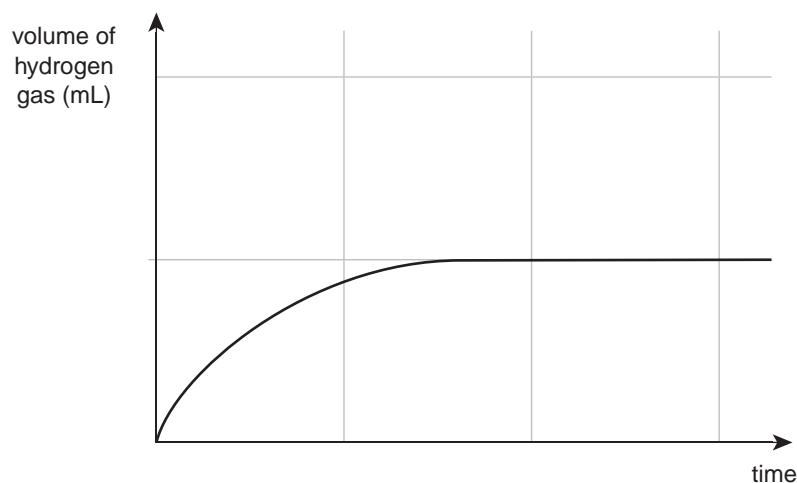

On the grid above, sketch the graph expected if the original experiment was repeated but magnesium powder was used instead of magnesium ribbon.

1 mark
Total 7 marks

Question 4

This question concerns the ionisation in water of the weak acid ethanoic acid (CH_3COOH).

- a. Write an equation to show the ionisation of ethanoic acid in water.

_____ 1 mark

- b. Write an expression for the ionisation constant, K_a , for ethanoic acid.

_____ 1 mark

- c. The percentage ionisation for ethanoic acid solutions of different concentrations is shown in the table below.

Acid concentration (M)	Percent ionisation
0.0050	5.8
0.050	1.9
0.50	?

- i. Calculate the percent ionisation for the 0.50 M acid solution.

- ii. Use Le Chatelier's principle to explain why the percent ionisation increases as the concentration of the acid decreases.

- iii. Would you expect the pH of the solutions to increase or decrease as the concentration of the acid decreases? Explain your choice.

3 + 2 + 2 = 7 marks
Total 9 marks

Question 5

An industrial process that manufactures chemicals involves the following equilibrium reaction:

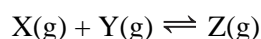

The following data about the reaction was obtained by experiment.

Temperature (K)	Equilibrium constant (M^{-1})	Time to produce one mole of Z(g)
298	7.5×10^7	4 hours
400	1.2×10^4	10 minutes
500	75	20 seconds
600	2.5	0.5 seconds
700	0.3	0.05 seconds

- a. Show how it can be deduced that the reaction is exothermic.

2 marks

- b. A 250 mL sample of a reaction mixture at 500 K was taken to determine whether equilibrium had been reached. The reaction mixture contained 0.020 mol of X, 0.015 mol of Y and 0.10 mol of Z.

- i. Show that the reaction is not at equilibrium.

- ii. In which direction (forward or backward) will the reaction move to achieve equilibrium?

2 + 1 = 3 marks

- c. To increase the yield in industrial processes that manufacture chemicals, one method involves removing the product from the reaction vessel without stopping the reaction.

Suggest why it would be difficult to use this technique to increase the yield of chemical Z.

1 mark

- d. A suitable catalyst has been found for the reaction.
- i. Indicate the effect of the catalyst on the following reaction variables. (Indicate your answers by placing one tick in each row of the table below.)

	Decreased	Unchanged	Increased
Equilibrium yield of the chemical Z			
Rate of the forward reaction			
Activation energy of the reverse reaction			
Value of the equilibrium constant			

- ii. The catalyst is not used in the industrial production process.
Suggest a possible reason why the catalyst is not used in the industrial manufacture of chemical Z.

2 + 1 = 3 marks

- e. What conditions of temperature are likely to be used in industry for the economic manufacture of chemical Z? Explain your choice.

2 marks

- f. During this semester you have studied the production of one of the following chemicals.
Circle the chemical you have studied in detail this semester.

ammonia**ethene****sulfuric acid****nitric acid**

- i. Describe one safety precaution which must be observed during the production of your chosen chemical.

- ii. Describe one environmental consideration which must be observed during the production of your chosen chemical.

1 + 1 = 2 marks
Total 13 marks

Question 6

One important use of electrolysis is the electrorefining of copper. After copper ore is heated in a blast furnace to remove non-metal elements, blocks of 'blister copper' of 98% purity are produced. These blocks become electrodes in electrolytic cells designed to yield almost pure copper.

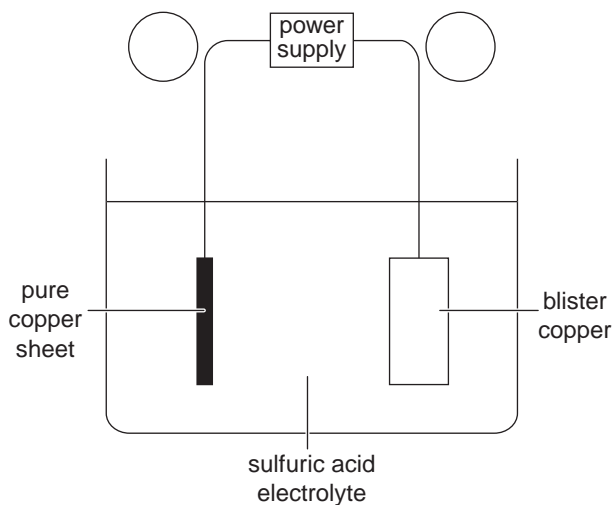

- a. In the circles on the diagram, mark the polarity (+ or -) of each electrode.

1 mark

- b. 'Blister copper' contains the metal impurities silver, gold, zinc and nickel. The voltage is adjusted so that the copper in the 'blister copper' is oxidised to its ions.

- i. Which of the metal impurities will not be oxidised to their ions in the cell?

- ii. Explain why some of the metal impurities will be oxidised in the cell.

1 + 1 = 2 marks

- c. Explain why it would not be possible to use this electrorefining technique to produce pure aluminium from blocks of aluminium containing impurities.

2 marks

- d.** Electrolysis of a solution of copper ions using copper electrodes also allows the value of the Avogadro constant to be determined accurately. The data from such an experiment is shown below.

Current used in electrolytic cell	0.100 amperes
Time current was applied	50 minutes 35 seconds
Mass of copper deposited	0.100 grams

- i.** Calculate the charge transferred in the electrolytic cell.

- ii.** Calculate the amount (in mol) of electrons required to deposit the copper.

- iii.** Calculate the charge carried by one mole of electrons.

- iv.** Using the charge on one electron, determine the number of electrons in 1 mole, that is, determine the Avogadro constant.

1 + 2 + 1 + 1 = 5 marks
Total 10 marks

END OF QUESTION AND ANSWER BOOKLET