CHEMISTRY VCE UNITS 3&4 DIAGNOSTIC TOPIC TESTS 2008

TEST 8: ELECTROCHEMISTRY

TOTAL 35 MARKS (45 MINUTES)

Student's Name: _____ Teacher's Name: _____

Directions to students

Write your name and your teacher's name in the spaces provided above.
Answer all questions in the spaces provided.

SECTION A: MULTIPLE-CHOICE QUESTIONS

Instructions for Section A

For each question in Section A, choose the response that is correct and circle your choice.

Choose the response that is **correct** or **best answers** the question.

A correct answer scores 1, an incorrect answer scores 0.

Marks will **not** be deducted for incorrect answers.

No marks will be given if more than one answer is completed for any question.

Question 1

Which of the following would be predicted to spontaneously reduce aqueous Pb^{2+} ions, but not spontaneously reduce aqueous Co^{2+} ions?

- A. Sn^{2+} ions
- B. Sn atoms
- C. H^+ ions
- D. Fe atoms

Question 2

Which of the following is a feature of the standard hydrogen half-cell used in the construction of the electrochemical series?

- A. a 1.0 M nitric acid electrolyte
- B. a temperature of 273 K
- C. a graphite electrode
- D. hydrogen gas at 1 atm pressure

Question 3

The reactions occurring in an experimental methanol fuel cell are shown below.

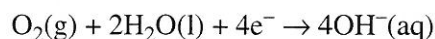

During the operation of the cell, the pH of the solution near the positive electrode would initially

- A. increase.
- B. decrease.
- C. remain unchanged.
- D. decrease then increase steadily as diffusion occurs.

Question 4

Which of the following comparisons between galvanic and electrolytic cells is **incorrect**?

Galvanic

- A. chemical energy is converted to electrical energy
- B. spontaneous redox reactions occur
- C. oxidation occurs at the positive electrode
- D. oxidation occurs at the anode

Electrolytic

- electrical energy is converted to chemical energy
- non-spontaneous redox reactions occur
- oxidation occurs at the negative electrode
- oxidation occurs at the anode

Question 5

Which of the following occurs during the electrolysis of molten sodium chloride using graphite electrodes?

- A. Cations move towards the positive electrode.
- B. Electrons move through the electrolyte towards the positive electrode.
- C. A gas is produced at the negative electrode.
- D. Both cations and anions move through the electrolyte.

Question 6

The nickel–cadmium (NiCad) cell is a secondary cell with a wide variety of uses including video cameras, cordless drills and phones. This cell uses an alkaline electrolyte.

The overall reaction occurring when the cell is in use is shown below.

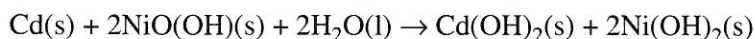

The products formed at the positive electrode when the cell is **recharged** are

- A. Cd and H₂O.
- B. NiO(OH) and H₂O.
- C. Cd and OH⁻.
- D. NiO(OH) and H⁺.

Questions 7 and 8 refer to the following information.

Samples of four metals (W, X, Y and Z) were each placed in separate solutions containing the cations W^{2+} , X^{2+} and Y^{2+} . If a reaction occurred, a tick was placed in the appropriate cell of the results table shown below.

		Metal			
		W	X	Y	Z
Solution	W^{2+}			✓	✓
	X^{2+}	✓		✓	✓
	Y^{2+}				✓

Question 7

Which of the following shows the metals in order of **decreasing** reductant strength?

- A. Z, Y, W, X
- B. Y, W, X, Z
- C. X, W, Y, Z
- D. Z, X, W, Y

Question 8

Which metals would cause a deposit of Z to form if they were placed in a solution containing the cation Z^{2+} ?

- A. metals W and Y only
- B. metals W and X only
- C. metals W, X and Y
- D. none of the metals

Question 9

Which of the following occurs during the electrolysis of a dilute copper(II) sulfate solution using graphite electrodes?

- A. The cathode decreases in mass.
- B. A colourless gas is produced at the cathode.
- C. A colourless gas is produced at the positive electrode.
- D. The electrolyte solution becomes darker in colour.

Question 10

A 0.5 M nickel sulfate solution was electrolysed for five minutes.

If the experiment was repeated, which of the following changes would cause the **largest** increase in the amount of nickel deposited?

- A. increasing the time for the electrolysis by one minute
- B. increasing the concentration of the solution to 0.6 M
- C. increasing the surface area of the electrodes used by twenty percent
- D. increasing the temperature of the solution from 20°C to 25°C

SECTION B: SHORT-ANSWER QUESTIONS

Instructions for Section B

Answer **all** questions in the spaces provided.

To obtain full marks you should

- give simplified answers with an appropriate number of significant figures to all numerical questions; unsimplified answers will not be given full marks.
- show all working in your answers to numerical questions. No credit will be given for an incorrect answer unless it is accompanied by details of the working.
- make sure chemical equations are balanced and that the formulas for individual substances include an indication of state; for example $\text{H}_2(\text{g})$; $\text{NaCl}(\text{s})$.

Question 1

Two metals (X and Y) and aqueous solutions of their nitrate salts were used to construct a galvanic cell as shown below. Metal X is a stronger reductant than metal Y.

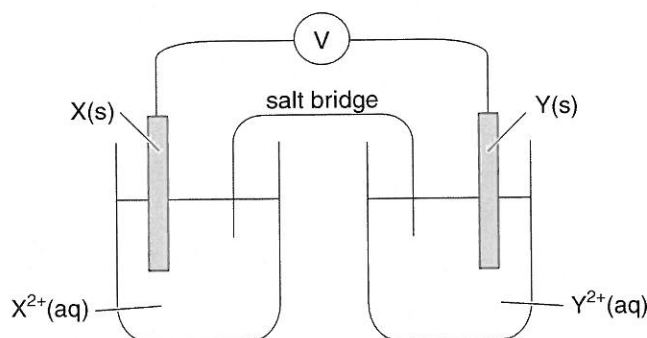

- a. Write a balanced ionic equation for the reaction occurring in the cell.

_____ 1 mark

- b. Which electrode (X or Y) is the anode?

_____ 1 mark

- c. Which electrode (X or Y) carries a positive charge?

_____ 1 mark

- d. In which direction (towards X or towards Y) do cations move through the salt bridge?

_____ 1 mark

- e. Give the formula for a substance that would be suitable for use in the salt bridge of this cell.

_____ 1 mark

Total 5 marks

Question 2

The lead–acid accumulator (car battery) is a well-known example of a secondary cell. The battery consists of six separate cells connected in series. The electrolyte used is an approximately 4 M H₂SO₄ solution.

The reaction occurring during discharge of the battery may be represented by the following half-equations.

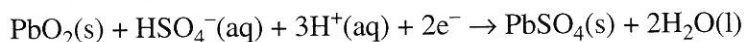
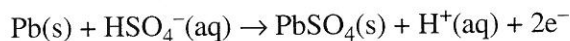

- a. Write the overall equation for the reaction occurring during discharge.

1 mark

- b. What feature of the lead–acid accumulator enables it to function as a secondary cell?

1 mark

- c. To which terminal of a power supply (positive or negative) would the PbO₂ coated electrode be connected for recharging of the lead–acid accumulator? Explain your choice.

2 marks

- d. During recharging of the car battery, additional reactions may occur when the hydrogen ions and water in the electrolyte are reduced or oxidised.

Write a half-equation for the process involving either water or hydrogen ions that may occur at the anode during recharging of the car battery.

1 mark
Total 5 marks

Question 3

A solution of a chromium salt is electrolysed in a cell by the passage of a current of 3.50 A for 7.00 minutes exactly. The mass of chromium metal deposited on one electrode was 0.264 g.

a. i. Calculate the amount (in mol) of chromium deposited.

ii. Calculate the amount (in mol) of electrons used to deposit the chromium.

iii. Hence calculate the charge on the chromium ion in the salt.

1 + 1 + 1 = 3 marks

b. Explain why it is not possible to deposit magnesium by the electrolysis of a magnesium salt solution.

2 marks

Total 5 marks

Question 4

a. When a 5 M solution of potassium chloride is electrolysed using inert electrodes, gas is evolved at each electrode.

Write the half-equation for the gas producing

i. oxidation reaction.

ii. reduction reaction.

1 + 1 = 2 marks

b. Copper pieces are added to a dilute solution of hydrochloric acid.

i. What would you expect to observe?

ii. Write a balanced equation for any reaction occurring, or explain why no reaction would be observed.

1 + 1 = 2 marks

- c. Consider the standard reduction potentials for the three half-cells listed below.

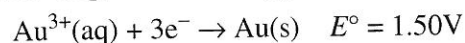

- i. Which species shown in the half-equations is the strongest reductant?

ii. Write an equation for the reaction occurring in the combination of half-cells that would produce the largest voltage when arranged as a galvanic cell.

1 + 1 = 2 marks

- d. Sulfuric acid is a strong oxidant with a standard reduction potential as shown below.

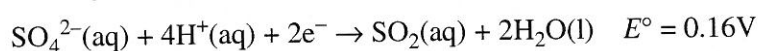

A 1.0 M solution of sulfuric acid is electrolysed using inert electrodes.

Explain why the product at the cathode is hydrogen and not sulfur dioxide.

2 marks

- e. The electrodes in a hydrogen–oxygen fuel cell serve several functions.

State **two** of these functions.

2 marks

Total 10 marks

CHEMISTRY VCE UNITS 3&4 DIAGNOSTIC TOPIC TESTS 2008

TEST 7: ENERGY SOURCES AND THE ENERGY OF CHEMICAL REACTIONS

SUGGESTED SOLUTIONS AND MARKING SCHEME

SECTION A: MULTIPLE-CHOICE QUESTIONS

Question 1 D

There is a number of gas-fired electricity generators in Victoria and New South Wales (so **A** is incorrect). Solar energy is used extensively in domestic applications (so **B** is incorrect), and hydroelectricity generates considerable power in Tasmania and the mainland (so **C** is incorrect). While there is a nuclear reactor at Lucas Heights in Sydney, it is not used in the generation of electricity.

Question 2 A

The fermentation (or anaerobic respiration) of high-sugar crops such as sugar cane is the major process by which ethanol is produced. The fractional distillation of crude oil yields petrol, diesel and aviation fuel but not ethanol (so **B** is incorrect). The reaction of oils and fats with methanol generates biodiesel, not ethanol (so **C** is incorrect). The decomposition of organic waste is employed to manufacture biofuels, not ethanol (so **D** is incorrect).

Question 3 C

If the process of electricity generation was 100% efficient, the mass of coal required would be

$$\frac{9.0 \times 10^6}{12} = 7.5 \times 10^5 \text{ g.}$$

But the efficiency is only 35% (so **B** is incorrect),

$$\text{so } m(\text{coal}) = \frac{100}{35} \times 7.5 \times 10^5 = 2.1 \times 10^6 \text{ g or } 2100 \text{ kg (so C is correct).}$$

As the process is inefficient, more coal is required to obtain the required electrical power, not less. 35% of $7.5 \times 10^5 \text{ g} = 263 \text{ kg}$ (so **A** is incorrect).

If the energy required is multiplied by the energy per gram of coal rather than divided, at 35% yield an answer of $3.8 \times 10^4 \text{ kg}$ is obtained (so **D** is incorrect).

Question 4 B

The required equation has one mol of carbon as a reactant and 4 mol of H₂, so multiply the third equation by 2 and add it to the second equation. Methanol is a product of reaction in the desired process, so the first equation must be reversed.

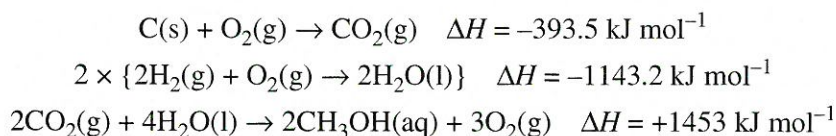

Add these three new equations to obtain the desired result.

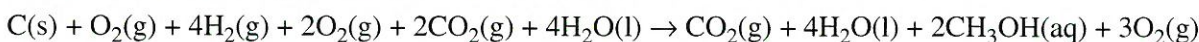

This cancels to $\text{C(s)} + 4\text{H}_2\text{(g)} + \text{CO}_2\text{(g)} \rightarrow 2\text{CH}_3\text{OH(aq)}$

$$\Delta H = -393.5 - 1143.2 + 1453 = -83.7 \text{ kJ mol}^{-1}$$

Question 5 C

From the equation, 2 mol of C₄H₁₀ yields 5750 kJ so x mol of C₄H₁₀ yields 74.9 kJ.

$$\frac{x}{2} = \frac{74.9}{5750}$$

$$x = 2 \times \frac{74.9}{5750} = 0.0261 \text{ mol}$$

$$\text{mass of butane} = n \times M = 0.0261 \times 58.0 = 1.51 \text{ g}$$

If the amount of butane is not converted to mass, 0.0261 g is obtained (so **A** is incorrect). If only 1 mol of butane is used (not 2 as the equation requires), 0.756 g of butane results (so **B** is incorrect). If the ratio from the equation is used to multiply by 2 rather than divide by 2, the result is 3.02 g (so **D** is incorrect).

Question 6 B

$$n(\text{ZnO}) = \frac{m}{M} = \frac{1.00 \times 10^6}{81.4} = 1.23 \times 10^4 \text{ mol}$$

From the equation, 2 mol of ZnO requires 8791 kJ, so 1.23×10^4 mol of ZnO requires x kJ.

$$\frac{x}{8791} = \frac{1.23 \times 10^4}{2}$$

$$x = \frac{1.23 \times 10^4 \times 8791}{2} = 54.0 \text{ MJ}$$

If only 1 mol of ZnO is used (not 2 as the equation requires), then 108 MJ of energy would be required (so **D** is incorrect). If ZnS is used in the mass calculation rather than ZnO, 45.1 MJ is required (so **A** is incorrect). If the equation ratio is also ignored, the answer is 90.2 MJ (so **C** is incorrect).

Question 7 **A**

In this case, the energy input heated both the aluminium container and the ethanol.

$$E_T = (c \times m \times \Delta T)_{\text{ethanol}} + (c \times m \times \Delta T)_{\text{aluminium}}$$

$$14\,200 = (2.46 \times 250.0 \times (33.9 - 15.6)) + (c_{\text{Al}} + 180.0 \times (33.9 - 15.6))$$

$$14\,200 = 11\,255 + c_{\text{Al}} \times 3294$$

$$c_{\text{Al}} = 0.894 \text{ J } ^\circ\text{C}^{-1} \text{ g}^{-1}$$

This is a challenging question with considerable scope for confusion. If the mass of both ethanol and aluminium are added and the calculation performed, the answer would be $1.03 \text{ J } ^\circ\text{C}^{-1} \text{ g}^{-1}$ (so **B** is incorrect). If the temperature change is taken as the final temperature of 33.9°C rather than ΔT then the answer would be $1.09 \text{ J } ^\circ\text{C}^{-1} \text{ g}^{-1}$, (so **C** is incorrect). Note that the specific heat capacity of water is $4.18 \text{ J } ^\circ\text{C}^{-1} \text{ g}^{-1}$ (so **D** is incorrect).

Question 8 **C**

$$n(\text{C}_2\text{N}_2) = \frac{m}{M} = \frac{15.0}{52.0} = 0.288 \text{ mol}$$

From the equation, if 0.288 mol of C_2N_2 yields 312 kJ, then 1.00 mol of C_2N_2 yields ΔH .

$$\frac{\Delta H}{312} = \frac{1.00}{0.288}, \text{ so } \Delta H = \frac{1.00 \times 312}{0.288} = 1082$$

So $\Delta H = -1080 \text{ kJ mol}^{-1}$ (correct to 3 significant figures)

If the mass of cyanogen (C_2N_2) is not first converted to mol, the answer would be 20.8 kJ g^{-1} (so **A** is incorrect). If the mol amount of C_2N_2 is multiplied by the energy released, the answer would be 90 kJ mol^{-1} (so **B** is incorrect). If the mass of C_2N_2 is simply multiplied by the energy released, the answer would be 4680 kJ mol^{-1} (so **D** is incorrect).

Question 9 **D**

$$\text{CF} = \frac{E}{\Delta T} = \frac{VI t}{\Delta T} \text{ J } ^\circ\text{C}^{-1}$$

$$\text{So CF} = \frac{4.72 \times 3.18 \times 150}{26.9 - 17.0} = 227 \text{ J } ^\circ\text{C}^{-1}$$

If ΔT and t are swapped over in the formula, **A** is obtained. If the time is not converted to seconds but is left as 2.5 minutes, **B** is obtained. If the correct formula is used but $\Delta T = 26.9^\circ\text{C}$, **C** is obtained.

Question 10 **D**

$$\text{calibration factor} = 1.07 \text{ kJ } ^\circ\text{C}^{-1}$$

$$n(\text{C}_6\text{H}_4\text{O}_2) = \frac{m}{M} = \frac{0.841}{108} = 7.79 \times 10^{-3} \text{ mol}$$

$$E = \text{CF} \times \Delta T = 1.08 \times (44.5 - 24.4)$$

$$= 1.08 \times 20.1$$

$$= 21.7 \text{ kJ}$$

$$\Delta H = \frac{E}{n} = \frac{21.7}{7.79 \times 10^{-3}} = -2790 \text{ kJ mol}^{-1}$$

If the mass of quinone ($\text{C}_6\text{H}_4\text{O}_2$) is not first converted to mol the answer would be 25.8 kJ g^{-1} (so **C** is incorrect). If the energy released is calculated and the answer is not divided by the amount of quinone, the answer would be 21.7 kJ mol^{-1} (so **B** is incorrect). If the calibration factor is divided by ΔT rather than multiplying by ΔT , the answer would be 6.90 kJ mol^{-1} (so **A** is incorrect).

SECTION B: SHORT-ANSWER QUESTIONS

Question 1

- a. i. chemical $\frac{1}{2}$ mark
- ii. thermal $\frac{1}{2}$ mark
- iii. mechanical or kinetic $\frac{1}{2}$ mark
- iv. electrical $\frac{1}{2}$ mark
- b. i. Compared with black coal, brown coal contains more water and less carbon. 1 mark
- ii. Any one of:
- the conversion of the chemical potential energy of coal into the thermal energy of steam
 - the conversion of the thermal energy in steam into the mechanical (kinetic) energy of the spinning turbine
- 1 mark
- c. i. Each uranium nucleus undergoes a controlled fission reaction which releases a vast amount of the energy stored in the nucleus ($E = mc^2$). 1 mark
This energy is then used to boil water. The steam created is used to spin a turbine, thus creating electricity (similar to electricity generation in coal-fired power plants). 1 mark
- d. Any two of
- The wastes from nuclear reactions are radioactive and difficult to store and manage.
 - People are fearful of explosions/terrorist attacks on nuclear power plants.
 - Nuclear fuels can be misappropriated and used for nuclear weapons programs.
 - Nuclear power plants are expensive to build and require government regulatory approval.
 - Plants need to be near cities for ease of energy delivery and availability of workforce, but residents are often unhappy about plants being built in their neighbourhoods.

2 marks

1 mark for each appropriate reason

Total 8 marks

Question 2

- a. $d(\text{ammonia}) = \frac{m}{V} = 0.80 \text{ g mL}^{-1}$
- so $m(\text{ammonia}) = d \times V = 0.80 \times 500 = 400 \text{ g}$ 1 mark
- latent heat = $\frac{E}{m} = \frac{548\,000}{400} = 1370 \text{ J g}^{-1}$ 1 mark
- b. From the equation, 1 mol of CH_4 yields 890 kJ, so x mol of CH_4 yields 548 kJ.
- $$\frac{x}{1} = \frac{548}{890}$$
- so $x = \frac{1 \times 548}{890} = 0.616 \text{ mol}$ 1 mark
- The volume of methane required = $n \times V_M = 0.616 \times 24.5 = 15.1 \text{ L}$ 1 mark

Total 4 marks

CHEMISTRY VCE UNITS 3&4 DIAGNOSTIC TOPIC TESTS 2008

TEST 8: ELECTROCHEMISTRY

SUGGESTED SOLUTIONS AND MARKING SCHEME

SECTION A: MULTIPLE-CHOICE QUESTIONS

Question 1 B

To spontaneously reduce Pb^{2+} ions, the reductant must be lower in the electrochemical series than Pb, i.e. it must be a stronger reductant than Pb. If the reductant is not able to reduce Co^{2+} ions it must be above Co in the electrochemical series, i.e. it must be a weaker reductant than Co. Sn atoms are the only species listed that fit the requirements.

Question 2 D

The standard half-cell uses 1.0 M hydrochloric acid, not 1.0 M nitric acid as the electrolyte (so A is incorrect). The temperature is 25°C (298 K), not 273 K (so B is incorrect). The electrode is platinum with platinum black, not graphite (so C is incorrect). Hydrogen gas at 1 atm pressure is used.

Question 3 A

The positive electrode in a fuel cell is the cathode. Reduction occurs at the cathode. Thus OH^- ions will be produced at the positive electrode, causing the pH to increase.

Question 4 C

In galvanic cells, the spontaneous oxidation produces a negatively charged anode. In an electrolytic cell, the anode is positive as the power supply withdraws electrons, forcing an oxidation to occur. C is therefore incorrect, and so is the required response. The comparisons in A, B and D are correct.

Question 5 D

At the positive anode, oxidation occurs. $2\text{Cl}^-(\text{l}) \rightarrow \text{Cl}_2(\text{g}) + 2\text{e}^-$

At the negative cathode, reduction occurs. $\text{Na}^+(\text{l}) + \text{e}^- \rightarrow \text{Na}(\text{l})$

Cations (Na^+) move towards the negative electrode (so A is incorrect). Electrons move through the external wires, not through the electrolyte (so B is incorrect). A gas is produced at the positive anode, not the negative electrode (so C is incorrect). Both cations and anions move through the electrolyte.

Question 6 B

Oxidation occurs at the positive electrode of the electrolytic cell operating during the recharging of the NiCad cell. The best reductant, Ni(OH)₂ (with Ni in a +2 oxidation state) is oxidised to NiO(OH) (with Ni in a +3 oxidation state). The products are NiO(OH) and H₂O.

Question 7 A

W reacts with X²⁺. W is therefore a stronger reductant than X. Y reacts with W²⁺ and X²⁺. Y is therefore a stronger reductant than W and X. Z reacts with W²⁺, X²⁺, and Y²⁺. Z is therefore a stronger reductant than W, X and Y. The order of reductant strength is therefore Z > Y > W > X.

Question 8 D

Z is the strongest reductant. Z²⁺ is the weakest oxidant, so it will be unable to react with any of the metals.

Question 9 C

At the positive anode, oxidation occurs. $2\text{H}_2\text{O}(\text{l}) \rightarrow \text{O}_2(\text{g}) + 4\text{H}^+(\text{aq}) + 4\text{e}^-$

At the negative cathode, reduction occurs. $\text{Cu}^{2+}(\text{aq}) + 2\text{e}^- \rightarrow \text{Cu}(\text{s})$

The cathode increases in mass (so **A** is incorrect). A colourless gas is produced at the positive electrode, not at the cathode (so **C** is correct and **B** is incorrect). The electrolyte solution becomes lighter in colour due to the decreasing Cu²⁺ concentration (so **D** is incorrect).

Question 10 A

$$n(\text{e}^-) = \frac{I \times t}{F} \text{ mol}$$

$$n(\text{Ni}) = \frac{1}{2} \times n(\text{e}^-) \text{ mol}$$

$$m(\text{Ni}) = n \times M = \frac{1}{2} \times \frac{I \times t}{F} \times 58.7 \text{ g}$$

Increasing the time for electrolysis by 20% will increase the mass of nickel deposited. Changes in the surface area, concentration and temperature would have little effect on the mass of nickel deposited over the five minute time interval.

SECTION B: SHORT-ANSWER QUESTIONS

Question 1

- a. $X(s) + Y^{2+}(aq) \rightarrow X^{2+}(aq) + X(s)$ 1 mark
- b. X 1 mark
Oxidation occurs at the anode.
- c. Y 1 mark
Electrons flow towards the positive cathode where they are accepted by the oxidant in the solution.
- d. towards Y 1 mark
Cations flow into the half-cell where reduction is occurring. The flow of cations balances the negative charge accumulating in the half-cell as a result of the reduction process.
- e. For example: $KNO_3(aq)$ 1 mark

Total 5 marks

Question 2

- a. $Pb(s) + 2H_2SO_4(aq) + PbO_2(s) \rightarrow 2PbSO_4(s) + 2H_2O(l)$ 1 mark
- b. The products of the electrode reactions adhere to the electrodes. This enables the reactions to be reversed by the application of a current in the recharging process. 1 mark
- c. positive 1 mark
The reverse of the second equation to regenerate the $PbO_2(s)$ is an oxidation. The electrode must therefore be positive to force the oxidation (loss of electrons). 1 mark
- d. $2H_2O(l) \rightarrow O_2(g) + 4H^+(aq) + 4e^-$ 1 mark
Oxidation occurs at the anode.

Total 5 marks

Question 3

- a. i. $n(Cr) = \frac{m}{M} = \frac{0.264}{52.0} = 5.08 \times 10^{-3} \text{ mol}$ 1 mark
- ii. $n(e^-) = \frac{I \times t}{F} = \frac{3.50 \times 7.00 \times 60}{96\,500} = 1.52 \times 10^{-2} \text{ mol}$ 1 mark
- iii. $n(e^-) : n(Cr) = 0.0152 : 0.00508 = 3 : 1$ 1 mark
The charge is therefore +3, i.e. Cr^{3+} .
- b. Water is a stronger oxidant than the magnesium ion. 1 mark
Water would therefore be reduced to form hydrogen and hydroxide, and the magnesium ion would not react to produce magnesium. 1 mark

Total 5 marks

Question 4

- a. i.** $2\text{Cl}^-(\text{aq}) \rightarrow \text{Cl}_2(\text{g}) + 2\text{e}^-$ 1 mark
In a concentrated chloride solution, the chloride will be oxidised in preference to the water molecule.
- ii.** $2\text{H}_2\text{O}(\text{l}) + 2\text{e}^- \rightarrow \text{H}_2(\text{g}) + 2\text{OH}^-(\text{aq})$ 1 mark
- b. i.** no reaction 1 mark
- ii.** Cu is a weak reductant. The hydrogen ion is not a sufficiently strong oxidant to react with copper. 1 mark
- c. i.** Mn 1 mark
The reductant with the lowest E° value.
- ii.** $3\text{Mn}(\text{s}) + 2\text{Au}^{3+}(\text{aq}) \rightarrow 2\text{Au}(\text{s}) + 3\text{Mn}^{2+}(\text{aq})$ 1 mark
The reductant with the lowest E° value reacting with the oxidant with the highest E° value.
- d.** While sulfuric acid is a strong oxidant, it will not be reduced at the cathode during electrolysis because the sulfate ion carries a negative charge, as does the cathode. 1 mark
The sulfate ion will therefore not be attracted to the cathode to produce sulfur dioxide.
The strongest oxidant that can be reduced is the hydrogen ion. This will be reduced to form hydrogen gas. 1 mark
- e.** Any two of:
- They function as catalysts for the redox reactions.
 - They are the site of reduction and oxidation reactions.
 - They allow gaseous reactants to diffuse through them.

2 marks

1 mark for each function

Total 10 marks

Question 3

- a. i.** The thermometer is used to measure the increase in temperature of the water surrounding the combustion chamber of the calorimeter. 1 mark
- ii.** The ignition coil (two wires with a heating coil between them) is designed to ignite the oxygen gas and so burn the substance held in the crucible. 1 mark
- iii.** The stirring device ensures that the heat given off by the combustion reaction is evenly distributed through the water. 1 mark

b. i. $n(\text{benzoic acid}) = \frac{m}{M} = \frac{1.731}{122.0} = 0.0142 \text{ mol}$ 1 mark

From the equation, 2 mol of benzoic acid yields 6454 kJ, so 0.0142 mol yields x kJ.

$$x = \frac{6454 \times 0.0142}{2} = 45.8 \text{ kJ}$$

$$\text{CF} = \frac{E}{\Delta T} = \frac{45.8}{24.8} = 1.85 \text{ kJ } ^\circ\text{C}^{-1}$$
 1 mark

- ii.** As ammonia has a significantly lower specific heat capacity than water, its temperature increases to a greater extent with the input of a given amount of energy.

As $\text{CF} = \frac{E}{\Delta T}$ and ΔT is larger, the calibration factor will be smaller. 1 mark

c. i. $\text{CF} = \frac{E}{\Delta T}$, so $E = 1.85 \times (65.6 - 35.3) = 55.8 \text{ kJ}$ 1 mark

If 3.00 mL of biofuel produces 55.8 kJ, then 1000 mL of biofuel produces x kJ.

$$\frac{x}{55.8} = \frac{1000}{3.00}$$

$$x = \frac{1000 \times 55.8}{3.00} = 1.86 \times 10^4 \text{ kJ per litre or } 18.6 \text{ MJ L}^{-1}$$
 1 mark

ii. $n(\text{C}_2\text{H}_5\text{OH}) = \frac{m}{M} = \frac{2.50}{46.0} = 0.0543 \text{ mol}$

From the equation, if 1 mol of $\text{C}_2\text{H}_5\text{OH}$ yields 1360 kJ, then 0.0543 mol of $\text{C}_2\text{H}_5\text{OH}$ yields x kJ.

$$\frac{x}{1360} = \frac{0.0543}{1}$$

$$x = \frac{0.0543 \times 1360}{1} = 73.9 \text{ kJ}$$
 1 mark

$$\text{CF} = \frac{E}{\Delta T}$$

$$\Delta T = \frac{E}{\text{CF}} = \frac{73.9}{1.85} = 40.0 \text{ } ^\circ\text{C}$$
 1 mark

Total 10 marks

Question 4

a. i. $E = c \times m \times \Delta T = 4.18 \times 200.0 \times 3.10 = 2590 \text{ J}$ 1 mark

ii. $n(\text{HCl}) = n(\text{NaOH}) = c \times V = 0.50 \times 0.100 = 0.0500 \text{ mol}$

$$\Delta H = \frac{E}{n} = \frac{2590}{0.0500} = 51.8$$

The heat of neutralisation, ΔH , = $-51.8 \text{ kJ mol}^{-1}$ 1 mark

b. Any two of:

- improving the insulation around the reaction chamber (beaker)
- placing a lid on the reaction chamber
- using a digital thermometer

1 mark

$\frac{1}{2}$ a mark for each correct response