



VCE CHEMISTRY 2008

YEAR 12 TRIAL EXAM UNIT 3

CONDITION OF SALE:

© Limited copyright. This paper may be photocopied without charge for use only within the school that has purchased the material. Our electronic copy only may be placed on the school intranet for the exclusive use by the teachers and students of the school that has purchased the material. They may **not** otherwise be reproduced (all or part) electronically, scanned into a school computer, forwarded via email, or placed on the Internet, without written consent of the publisher.

Time allowed: 90 Minutes
Total marks: 83

SECTION A

Contains 20 Multiple Choice Questions
22 minutes, 20 marks

SECTION B

Contains 6 Extended Response Questions
68 minutes, 63 marks

To download the Chemistry Data Book please visit the VCAA website:

http://www.vcaa.vic.edu.au/vce/studies/chemistry/chem1_sample_2008.pdf Page 20

Learning Materials by Lisachem

PO Box 2018, Hampton East, Victoria, 3188

Ph: (03) 9598 4564 Fax: (03) 8677 1725

Email: orders@learningmaterials.com.au or orders@lisachem.com.au

Website: www.learningmaterials.com.au

Student Name.....

VCE Chemistry 2008 Year 12 Trial Exam Unit 3

Student Answer Sheet

Instructions for completing test. Use only an HB pencil. If you make a mistake erase and enter the correct answer. Marks will not be deducted for incorrect answers.

Write your answers to the Short Answer Section in the space provided directly below the question. There are 20 Multiple Choice questions to be answered by circling the correct letter in the table below.

<i>Question 1</i>	A	B	C	D	<i>Question 2</i>	A	B	C	D
<i>Question 3</i>	A	B	C	D	<i>Question 4</i>	A	B	C	D
<i>Question 5</i>	A	B	C	D	<i>Question 6</i>	A	B	C	D
<i>Question 7</i>	A	B	C	D	<i>Question 8</i>	A	B	C	D
<i>Question 9</i>	A	B	C	D	<i>Question 10</i>	A	B	C	D
<i>Question 11</i>	A	B	C	D	<i>Question 12</i>	A	B	C	D
<i>Question 13</i>	A	B	C	D	<i>Question 14</i>	A	B	C	D
<i>Question 15</i>	A	B	C	D	<i>Question 16</i>	A	B	C	D
<i>Question 17</i>	A	B	C	D	<i>Question 18</i>	A	B	C	D
<i>Question 19</i>	A	B	C	D	<i>Question 20</i>	A	B	C	D

VCE Chemistry 2008 Year 12 Trial Exam Unit 3

Multiple Choice Section

Section A

*Section A consists of 20 multiple-choice questions.
Section A is worth approximately 24 per cent of the marks available.
Choose the response that is **correct** or **best answers** the question.
Indicate your choice on the answer sheet provide.*

Question 1

During an acid-base titration, a burette reading had to be made according to the liquid level shown in the diagram on the right.

The recorded burette reading should have been:

- A. 18.4;
- B. 17.6;
- C. 17.65;
- D. 18.35.



Question 2

Ethylamine may be prepared by reaction between chloroethane and ammonia. The maximum mass, in grams, of ethylamine that could be prepared from 3.225 g of chloroethane is:

- A. 2.04;
- B. 2.25;
- C. 3.23;
- D. 4.08.

Question 3

Sodium hydride dissolves water to produce the hydride ion, $\text{H}^{-}(\text{aq})$, according to

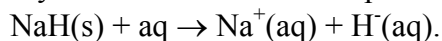

The hydride ion then immediately reacts with water according to

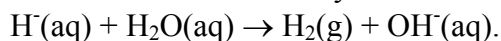

The reaction between $\text{H}^{-}(\text{aq})$ and water is most accurately described as:

- A. an hydrolysis reaction;
- B. an acid-base reaction;
- C. a redox reaction;
- D. both an acid-base reaction and a redox reaction.

Questions 4, 5, 6 and 7 refer to the following information

The diagram below shows a possible reaction pathway for producing an ester which has a distinctly pineapple odour.

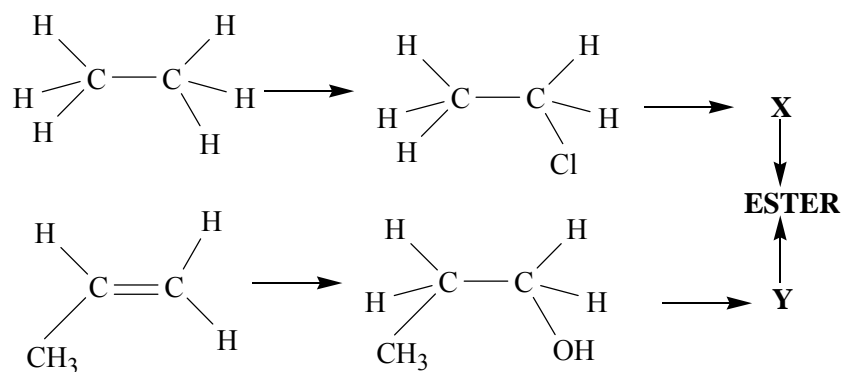

Question 4

Which of the following statements with respect to this pathway is **not** correct?

- X and Y react together in a condensation reaction in the presence of an acid catalyst.
- Chloroethane is converted to X in a substitution reaction
- 1-propanol is converted to Y in a redox reaction using Cu as the oxidant.
- The conversion of propene to 1-propanol is an addition reaction

Question 5

Comparison of the ¹³C NMR spectra and low resolution ¹H NMR of compound Y would show?

- More peaks on the ¹³C NMR spectrum.
- Fewer peaks on the ¹³C NMR spectrum.
- The same number of peaks on both spectra.
- TMS at a lower chemical shift on the ¹H spectrum.

Question 6

How many of the organic compounds in this reaction pathway would be expected to show a strong absorption band between 3200 and 3550 cm⁻¹ in their IR spectra?

- 1.
- 2.
- 3.
- 4.

Question 7

At what *m / e* ratio would the molecular ion be expected to appear in the mass spectrum of the ester produced via this reaction pathway?

- 88.
- 102.
- 106.
- 120.

Question 8

Concentrated nitric acid, HNO_3 , is a strong oxidising agent. Which of the following substances is least likely to be produced when nitric acid is the oxidant in a chemical reaction.

- A. NO_3^- .
- B. N_2 .
- C. NO_2 .
- D. NO .

Question 9

Aluminium will react with dilute sulfuric acid according to the equation

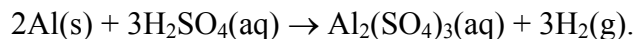

When 6.75 g of Al is added to excess dilute sulfuric acid and allowed to react to completion, 6.3 L of H_2 , at STP is collected.

What percentage of the H_2 produced in the reaction was **not** collected?

- A. 25.
- B. 37.
- C. 63.
- D. 75.

Question 10

When aqueous solutions of silver nitrate, AgNO_3 , and potassium chromate, K_2CrO_4 , are mixed, silver chromate, Ag_2CrO_4 , precipitates according to the ionic equation

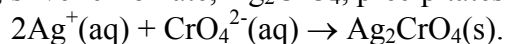

10 mL of 0.1 M $\text{AgNO}_3(\text{aq})$ is added to 20 mL of 0.05 M $\text{K}_2\text{CrO}_4(\text{aq})$ and reaction allowed to proceed to completion. Remaining unprecipitated at the end of the reaction would be:

- A. 0.05 mol Ag^+ ;
- B. 0.05 mol CrO_4^{2-} ;
- C. 0.0005 mol Ag^+ ;
- D. 0.0005 mol CrO_4^{2-} ;

Question 11

A 20.0 mL sample of a saturated aqueous solution of calcium hydroxide, $\text{Ca(OH)}_2(\text{aq})$, was titrated with 0.0300 M hydrochloric acid. 17.5 mL of the acid was required to reach the endpoint of the titration. The mass of calcium hydroxide, in grams, in one litre of the saturated solution was closest to:

- A. 1;
- B. 2;
- C. 0.02;
- D. 0.04.

Question 12

Shown below is a schematic diagram of an instrument used in modern chemical analysis

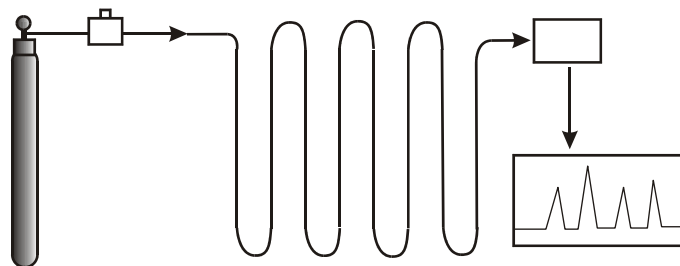

This instrument is commonly used in partnership with:

- A. a mass spectrometer;
- B. a nuclear magnetic resonance spectrometer ;
- C. an atomic absorption spectrometer;
- D. a high performance liquid chromatograph.

Question 13

Amino acids and nucleic acids are both important to the functioning of living organisms. Which one of the elements listed below may be present in some amino acids but **not** in nucleic acids?

- A. Hydrogen.
- B. Oxygen
- C. Phosphorus.
- D. Sulfur.

Question 14

Part of the primary structure of a section of a protein chain is represented below.

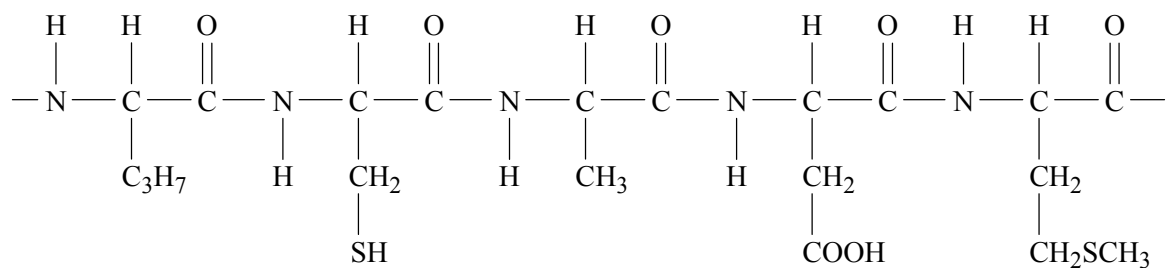

Which of the amino acids listed was not used to produce this section of the protein?

- A. Cysteine.
- B. Glycine.
- C. Methionine.
- D. Valine.

Question 15

Symbols for the chemical groups and bond types associated with DNA are shown below:

P phosphate group

A adenine

G guanine

— covalent bonds

D deoxyribose

C cytosine

T thymine

---- hydrogen bonding

Which of the diagrams below best represents the arrangement of the components of DNA?

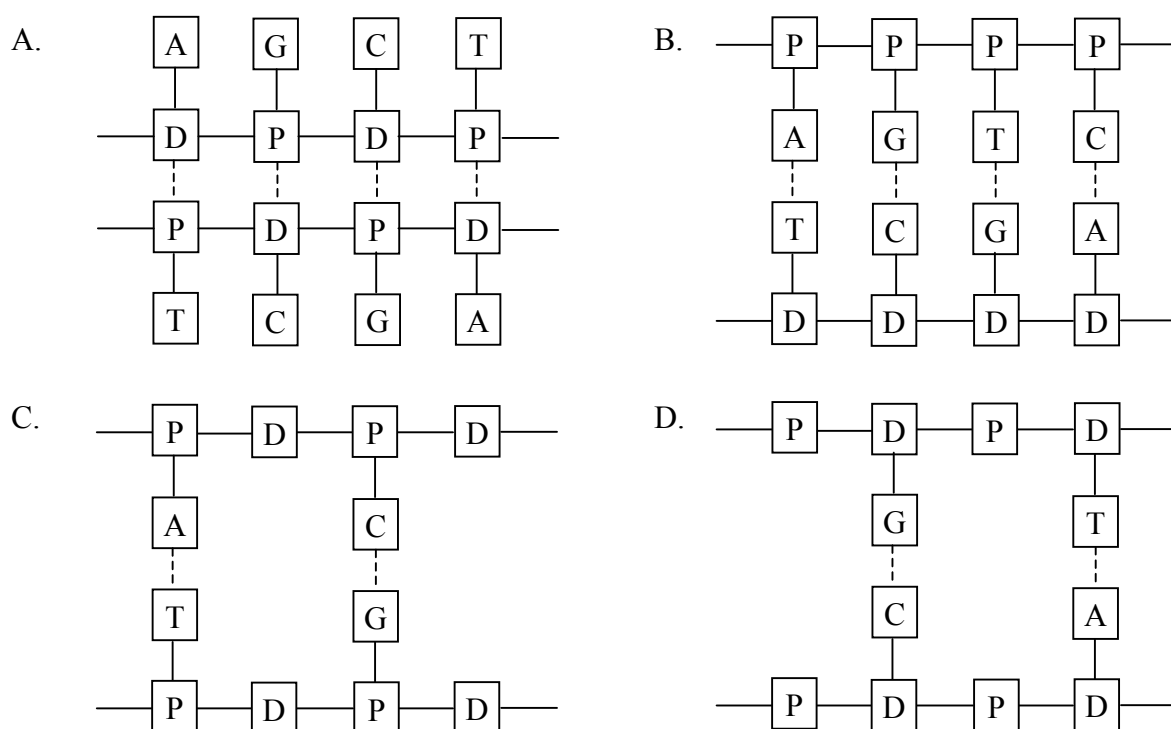

Question 16

Catalase is an enzyme produced in the liver. Catalase is **best** described as:

- A. a catalyst;
- B. a substance that changes the rate of a chemical reaction;
- C. a compound that is unaffected by changes in pH;
- D. a protein that increases the rate of a chemical reaction.

Question 17

The diagram below emphasises particular aspects of the structure of proteins.

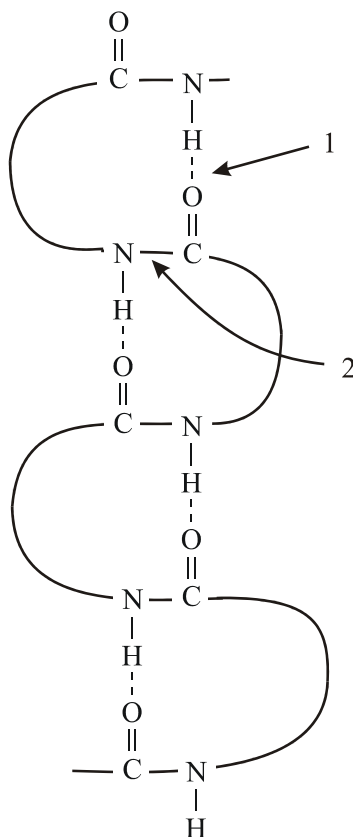

On this diagram the types of bond referred by labels **1.** and **2.** are:

- A. 1. covalent, 2. ionic;
- B. 1. hydrogen, 2. covalent;
- C. 1. covalent, 2. disulfide;
- D. 1. ionic, 2. covalent.

Question 18

Compared to a molecule of glucose, a molecule of deoxyribose has:

- A. one less carbon atom;
- B. one less oxygen atom;
- C. one less hydrogen atom;
- D. one less nitrogen atom.

Question 19

The following statement describes an aspect of the operation of a type of modern analytical instrument.

e.g. the electron in the third shell of a sodium atom will absorb energy of 589.0 nm wavelength. Only ground state atoms can absorb energy at this wavelength, and a hollow cathode lamp supplies the energy...

Which of the following analyses could be performed using this instrument?

- A. Determining the amount of gold in seawater.
- B. Determining the functional groups present in a new medicine.
- C. Determining the number of 'different' carbon atoms in a molecule.
- D. Determining the alcohol content of wine.

Question 20

The ratio of the peak areas in the ^1H NMR spectrum of 2-methylpropane is:

- A. 1 : 9.
- B. 1 : 3 : 3 : 3.
- C. 1 : 3 : 6.
- D. 2 : 5.

VCE Chemistry 2008 Year 12 Trial Exam Unit 3

Section B

*Section B consists of 6 short answer questions.
You should answer all of these questions in the spaces provided.
This section is worth approximately 76 per cent of the total marks available.
The marks allotted are shown at the end of each part of each question.
Questions should be answered in the spaces provided.*

Question 1

The concentration of copper ions in a solution was determined by converting the pale blue $\text{Cu}^{2+}(\text{aq})$ ions to dark blue $\text{Cu}(\text{NH}_3)_4^{2+}(\text{aq})$ ions and measuring the absorbance of the $\text{Cu}(\text{NH}_3)_4^{2+}(\text{aq})$ solution in a UV-Visible spectrometer at 600 nm.

Experimental data needed to construct a calibration curve was also collected and plotted as shown below.

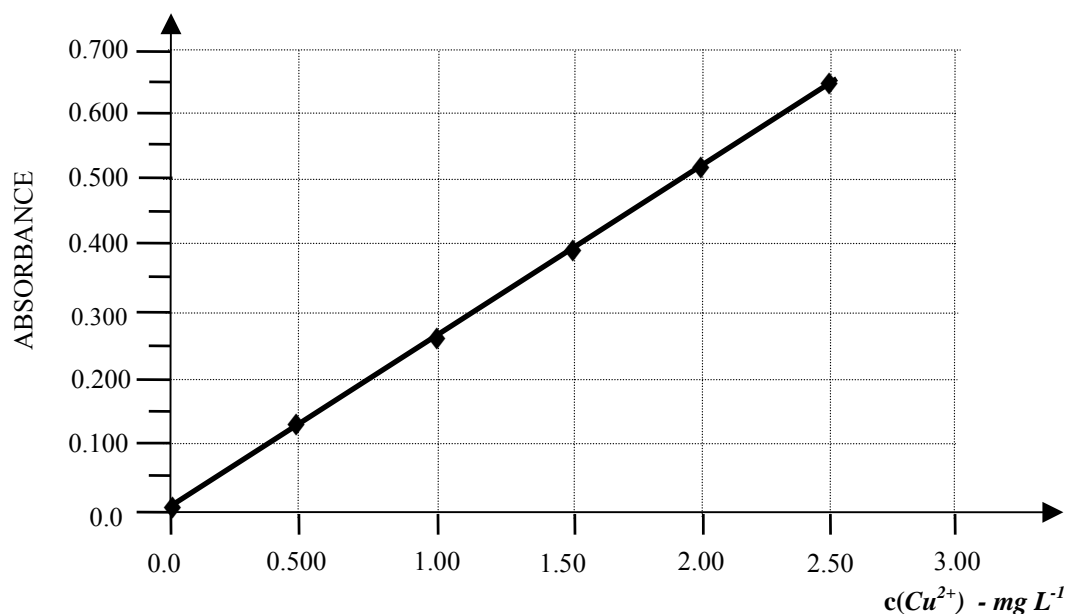

- a. What experimental data was needed to construct the calibration curve?

(1 mark)

- b. After the spectrometer had been calibrated, a 10.0 mL sample of the solution to be analysed was diluted to 100 mL with deionised water. Then 5.00 mL of this diluted solution was further diluted to 100 mL with deionised water prior to analysis. The absorbance of the final diluted solution was 0.520. Determine the concentration, in mol L⁻¹, of the original solution with respect to Cu²⁺(aq).

(3 marks)

- c. A wavelength around 600 nm is in the yellow region of spectrum of visible light. Why is this wavelength used in the analysis?

(2 marks)

- d. The concentration of Cu²⁺(aq) can also be determined by another spectroscopic technique. Give the name of this technique and describe the light source that would be used.

(2 marks)

Total marks = 8 marks

Question 2

A sample of bath salts contains a mixture of sodium carbonate, Na_2CO_3 and sodium hydrogen carbonate, NaHCO_3 .

In a volumetric analysis to determine the amounts of both Na_2CO_3 and NaHCO_3 present in a sample of bath salts, a 50.00 mL aliquot of an aqueous solution of the bath salts was titrated with 0.1020 M hydrochloric acid solution using phenolphthalein to indicate the end point. Methyl orange indicator was then added to the resulting solution and this was then titrated with the same acid to a second end point.

The reactions occurring during the titration are:



10.25 mL of the $\text{HCl}(\text{aq})$ was used to reach the phenolphthalein end point and a further 25.35 mL was used to reach the methyl orange end point.

- a. Describe the colour change that should occur at the end point of the first reaction?

(1 mark)

- b. Calculate the $n(\text{Na}_2\text{CO}_3)$ present in the original 50.00 mL aliquot of bath salts solution.

(2 marks)

- c. Determine the $n(\text{HCl})$ used between the phenolphthalein and methyl orange end points.

(1 mark)

- d. Describe the colour change that should occur at the end point of the second reaction.

(1 mark)

- e. Calculate the $n(\text{NaHCO}_3)$ reacting between the phenolphthalein and methyl orange end points.

(1 mark)

- f. Determine the molar concentration of the original 50.00 mL aliquot of bath salts solution with respect to NaHCO_3 .

(2 marks)

- g. In one analysis of the bath salts, the burette is rinsed with bath salts solution immediately before the hydrochloric acid is added to the burette. What effect would this error have on the calculated amounts of NaHCO_3 in the bath salts solution? Explain your answer

(2 marks)

Total 10 marks

Question 3

In an article entitled '*Chemistry and agriculture join to make a new generation of renewable fuels*' which appeared in *Chemical & Engineering News* – November 20, 2006 – Marc Reisch wrote '*Experts say biofuels won't replace all petroleum-derived gasoline or diesel. Instead, biofuels such as biodiesel, ethanol, and biobutanol will extend fossil fuel supplies.*'

a. Ethanol can be produced by fermentation of glucose or by an addition reaction from ethene.

i. Write a balanced equation for the production of ethanol by fermentation of glucose.

(2 marks)

ii. Explain why ethanol produced from glucose is classified as a biofuel.

(1 mark)

iii. Ethanol can also be produced from ethene. Write a balanced equation for this reaction.

(1 mark)

b. Biobutanol is also produced by the fermentation of sugars in the presence of the specific bacterium, *Clostridium acetobutylicum*. The products of this fermentation include hydrogen, butanoic acid and carbon dioxide as well as 1-butanol.

i. Draw structural formulae, showing all bonds, for 1-butanol and butanoic acid.

(2 marks)

- ii. The simulated high resolution proton NMR spectrum below is characteristic of one of the organic products of the fermentation of sugars in the presence of *Clostridium acetobutylicum*.

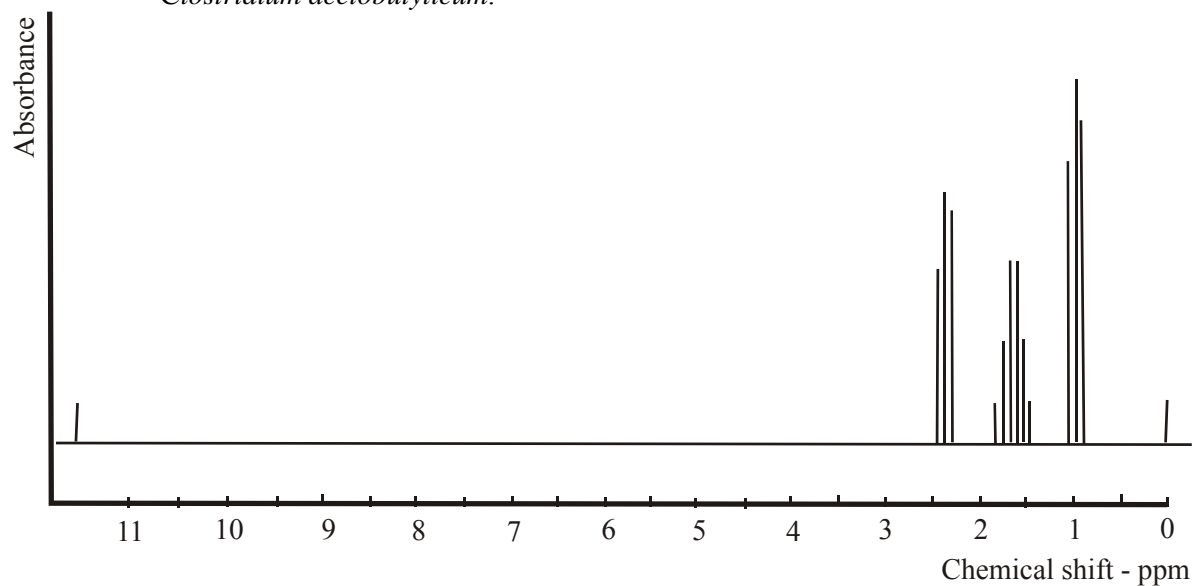

Identify this compound and explain how the information on the spectrum can be used to establish why it is the spectrum of one of the compounds but not the other.

(3 marks)

- iii. A distinct advantage of biobutanol over ethanol as a fuel biocomponent is that it can be blended into petrol at larger concentrations. It is also less likely than ethanol to separate out of a biofuel-petrol blend in the presence of any water. Why does 1-butanol dissolve more easily in petrol but less easily in water than ethanol?

(2 marks)

- c. Bio-diesel refers to fuels containing fatty acid methyl or ethyl esters made from any tri-glyceride oil molecule. The main reaction for converting oil to biodiesel is called transesterification. The Jatropha tree, a wild tree that grows readily in tropical areas carries a fruit with kernels that can be crushed to give an oil suitable for making biodiesel. The semi-structural formula for the triglyceride in this oil is shown below.

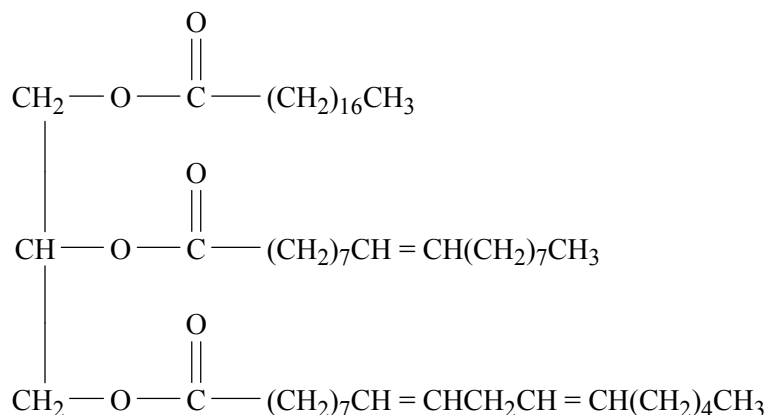

- i. The first stage in the transesterification process is the hydrolysis of the oil. Each molecule produces three fatty acids molecules and one other compound. Give the name of the other compound and draw its structural formula, showing all bonds.

(2 marks)

- ii. The second stage of the transesterification is the production of esters from the fatty acids released during hydrolysis. Write a balanced equation, using semi-structural formulae, for the production of the methyl ester of the monounsaturated fatty acid.

(2 marks)

- d. In support of biofuels it is sometimes claimed that the energy obtained from biomass does not add to global warming. How is this possible when all fuel combustion, including fuels produced from biomass, releases carbon dioxide into the atmosphere?

(1 mark)

Total 16 marks

Question 4

All three spectra shown below are of the same organic compound

a. IR spectrum

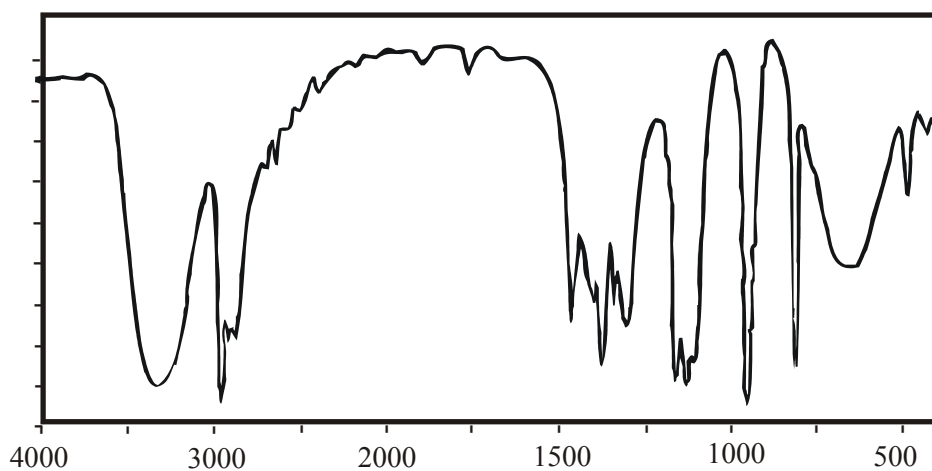

i. What functional group is indicated by the absorption band between 3200 and 3500 cm^{-1} ?

(1 mark)

ii. What is region of the spectrum to the right of 1500 cm^{-1} called?

(1 mark)

b. Mass spectrum

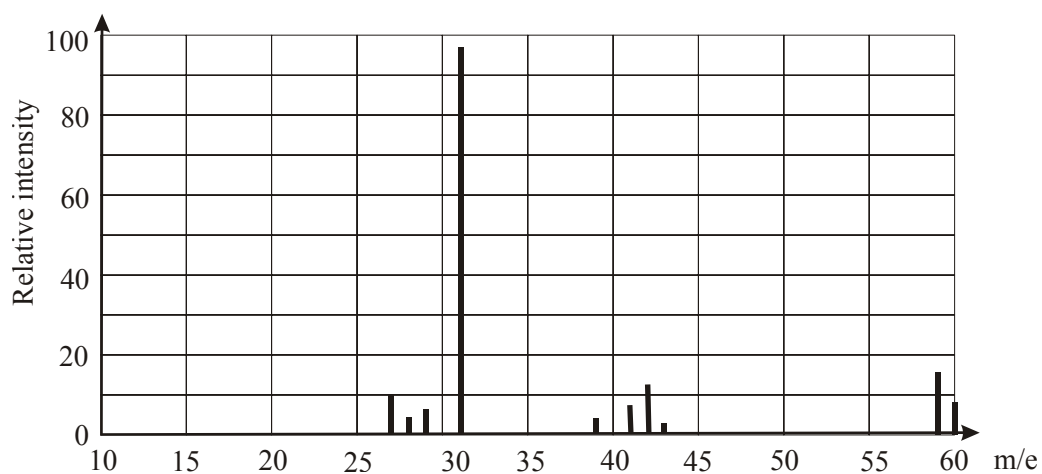

i. What is the relative molecular mass of the compound?

(1 mark)

- ii. On the basis of the functional group identified from the IR spectrum and the relative molecular mass of the compound, how many carbon atoms should be present in each molecule? Explain your reasoning.

(2 marks)

- c. ^1H NMR spectrum

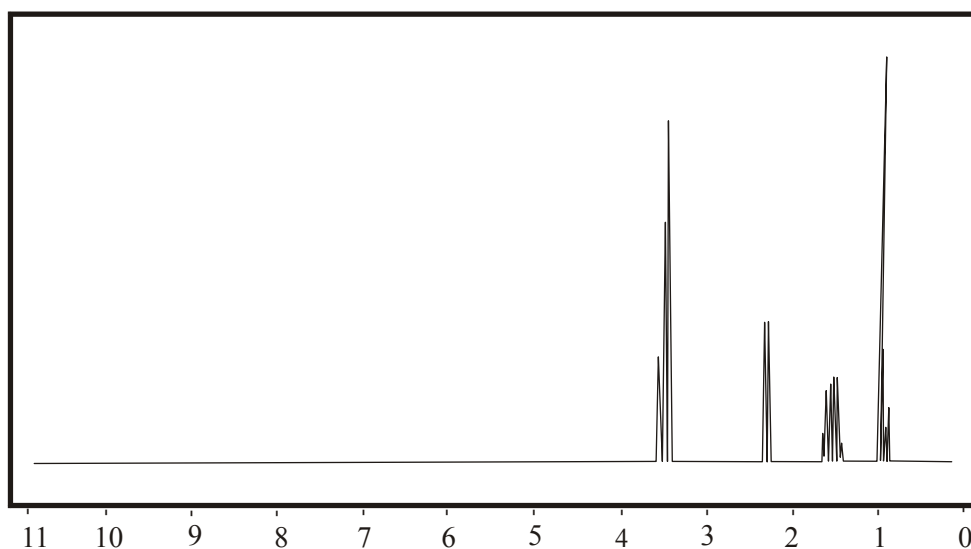

- i. How many different hydrogen environments are present in the molecules of the compound?

(1 mark)

- ii. Give the semi-structural formula for the compound.

(1 mark)

- iii. The peaks at chemical shifts 0.9 and 3.7 are both triplets. What causes the peaks for those hydrogen atoms to be split into triplets?

(1 mark)

- iv. The peak at chemical shift 1.6 is split into 6 finer peaks, i.e. a sextet. Referring to the semi-structural formula of the compound briefly explain why this occurs.

(1 mark)

- d. How many peaks would you expect to see on the ^{13}C NMR spectra of this compound?

(1 mark)

- e. This compound has one other isomer, containing the same functional group.

- i. Draw the structural formula of this isomer.

(1 mark)

- ii. State the number of peaks this isomer would show and its:

– low resolution ^1H NMR spectrum.

– ^{13}C NMR spectrum.

(2 marks)

Total marks = 13 marks

Question 5

Consider the information provided below.

Improving Liver Cancer Diagnosis

ScienceDaily (Oct. 7, 2007) — Researchers have identified proteins that could be used to improve the diagnosis of hepatocellular carcinoma, the most common type of liver cancer. They have used a state-of-the-art technique called two-dimensional difference gel electrophoresis to look for proteins whose copies are either increased or decreased in patients with hepatocellular carcinoma. Among the many proteins they found, two proteins were validated as novel potential markers of hepatocellular carcinoma.

- a. How do proteins act as markers for diseases such as cancers?

(1 mark)

- b. Proteins are produced by a reaction between amino acids. What type of reaction occurs and what functional group changes occur during this reaction?

(3 marks)

- c. Electrophoresis involves separation of molecules as they pass through a conducting gel under the influence of an applied electric field. Proteins and/or amino acids can be separated with the extent of movement depending on the charge on the molecules – determined by gel pH – and the mass of the molecules.

- i. Explain how the pH of the gel would affect the charge on an amino acid or protein.

(2 marks)

- ii. Towards which electrode (positive or negative) would the amino cysteine move during electrophoresis in a gel of pH 2.

(1 mark)

- d. Since proteins can be separated according to mass and charge in electrophoresis what analytical tool is then a vital part of protein identification.

(1 mark)

Total marks = 8 marks

Question 6

The molecules structures of two common analgesics are shown below.

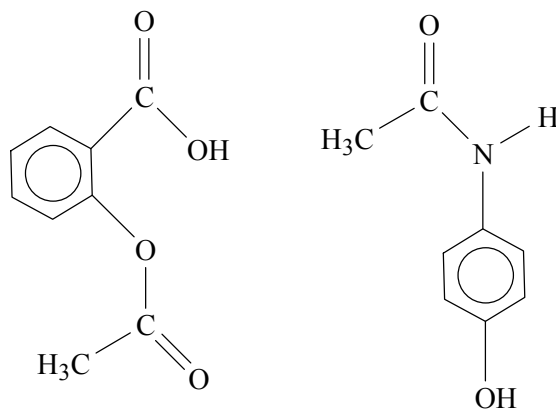

- a. One of the analgesics represented is paracetamol and the other one is aspirin Highlight and give the names of the two functional groups present in a paracetamol molecule.

(2 marks)

- b. Highlight and give the names of the two functional groups present in an aspirin molecule.

(2 marks)

- c. During hydrolysis, under alkaline conditions, aspirin is converted into a mixture of salicylic and ethanoic acids. Draw the molecular structure of salicylic acid.

(1 mark)

- d. A particular brand of analgesic states that each tablet contains 250 mg of aspirin, 250 mg of paracetamol and 65 mg of caffeine. In order to check this claim a thin-layer chromatography analysis was performed, using pure aspirin, pure paracetamol and pure caffeine for reference. The following chromatogram was developed.

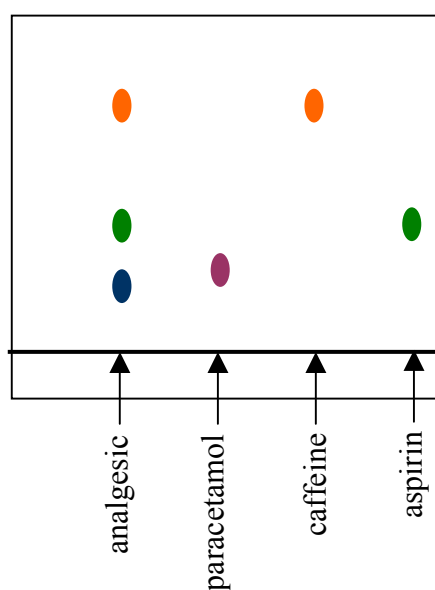

- i. What can be concluded, from this data, about the composition of the analgesic?

(2 marks)

- ii. In order to determine the relative amounts of the three substances present in the analgesic which chromatographic technique should be used?

(1 mark)

Total marks = 8 marks

End of Trial Exam

Suggested Answers VCE Chemistry 2008 Year 12 Trial Exam Unit 3

Multiple Choice Section

Section A

- Q1 C** Burettes are read from top to bottom and at the bottom of the meniscus (the slight concave curve formed at the top of the liquid). Since the bottom of the meniscus is halfway between 17.6 and 17.7 the correctly recorded reading would be **17.65**.
- Q2 B** The reaction for the preparation of ethylamine from chloroethane is
 $\text{CH}_3\text{CH}_2\text{Cl} + \text{NH}_3 \rightarrow \text{CH}_3\text{CH}_2\text{NH}_2 + \text{HCl}$
i.e. a maximum of 1 mol ethylamine can be produced for each 1 mol chloroethane reacting.
- $$\begin{aligned}n(\text{CH}_3\text{CH}_2\text{Cl}) \text{ reacting} &= m / M \\ &= 3.225 \text{ g} / 64.5 \text{ g mol}^{-1} \\ &= 0.0500 \text{ mol} \\ n(\text{CH}_3\text{CH}_2\text{NH}_2) \text{ produced} &= 0.0500 \text{ mol} \\ m(\text{CH}_3\text{CH}_2\text{NH}_2) \text{ produced} &= n \times M \\ &= 0.0500 \text{ mol} \times 45.0 \text{ g mol}^{-1} \\ &= \mathbf{2.25 \text{ g}}\end{aligned}$$
- Q3 D** The reaction $\text{H}^+(\text{aq}) + \text{H}_2\text{O}(\text{aq}) \rightarrow \text{H}_2(\text{g}) + \text{OH}^-(\text{aq})$ is an acid-base reaction with H^+ acting as a base, i.e. accepting a proton, and forming H_2 , and H_2O acting as an acid, i.e. donating a proton and forming OH^- . The redox nature of the reaction can be assessed by assigning oxidation numbers.

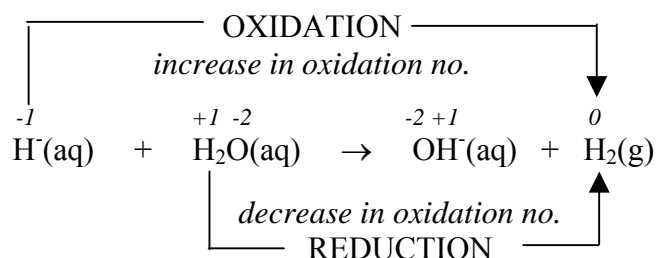

Hydrogen is both oxidised, from H^+ to H_2 , and reduced, from H_2O to H_2 . So the reaction is a redox reaction as well as an acid-base reaction.

- Q4 C** Consider the reactions occurring
 $\text{CH}_3\text{CH}_3 \rightarrow \text{CH}_3\text{CH}_2\text{Cl}$ – substitution
 $\text{CH}_3\text{CH}_2\text{Cl} \rightarrow \text{X}$, i.e. $\text{CH}_3\text{CH}_2\text{OH}$ – substitution
 $\text{CH}_3\text{CH}=\text{CH}_2 \rightarrow \text{CH}_3\text{CH}_2\text{OH}$ – addition
 $\text{CH}_3\text{CH}_2\text{CH}_2\text{OH} \rightarrow \text{Y}$, i.e. $\text{CH}_3\text{CH}_2\text{COOH}$ – oxidation
(X) $\text{CH}_3\text{CH}_2\text{OH} +$ (Y) $\text{CH}_3\text{CH}_2\text{COOH} \rightarrow$ (ESTER) $\text{CH}_3\text{CH}_2\text{COOCH}_2\text{CH}_3$ – condensation – using concentrated H_2SO_4 as a catalyst.
The conversion of 1-propanol, $\text{CH}_3\text{CH}_2\text{CH}_2\text{OH}$, to propanoic acid, $\text{CH}_3\text{CH}_2\text{COOH}$, is an oxidation reaction but requires an oxidant. Cu is a reductant, not an oxidant (see VCE Data Book Table 2). The oxidant commonly used is an acidified solution of dichromate ions, i.e. $\text{Cr}_2\text{O}_7^{2-}(\text{aq}) / \text{H}^+(\text{aq})$.

- Q5 C** Y is propanoic acid, $\text{CH}_3\text{CH}_2\text{COOH}$.
Propanoic acid will show **three peaks on its ^{13}C NMR spectrum** because it has **three different carbon environments**.

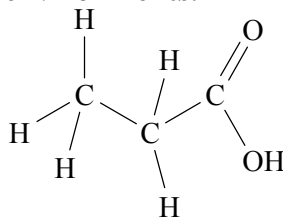

- Propanoic acid will show **three peaks on its ^1H NMR spectrum** because it has **three different hydrogen environments**.
- Q6 B** According to Table 7 in the VCE Data Book, the **hydroxy group, O-H (in alcohols)** alcohols will produce an **IR absorption band in the range between 3200 and 3550 cm^{-1}** .
Whilst the OH group in carboxylic acids will produce an IR absorption band in the range between 2500 and 3300 cm^{-1} , a particular acid may not produce its associated absorption band between 3200 and 3300 cm^{-1} .
There are **two alcohols** – ethanol (X), $\text{CH}_3\text{CH}_2\text{OH}$, and 1-propanol, $\text{CH}_3\text{CH}_2\text{CH}_2\text{OH}$, both of which show strong absorption between 3200 and 3550 cm^{-1} on their IR spectra.
- Q7 B** The **molecular ion** is formed as a result of an electron being knocked off each of the ester molecules when bombarded by a stream of electrons in the mass spectrometer.
The ester produced is ethyl propanoate, **$\text{CH}_3\text{CH}_2\text{COOCH}_2\text{CH}_3$**
(X) $\text{CH}_3\text{CH}_2\text{OH} + (\text{Y}) \text{CH}_3\text{CH}_2\text{COOH} \rightarrow (\text{ESTER}) \text{CH}_3\text{CH}_2\text{COOCH}_2\text{CH}_3 + \text{H}_2\text{O}$
 $M_r(\text{CH}_3\text{CH}_2\text{COOCH}_2\text{CH}_3) = 102$, i.e. the relative molecular mass of the ester is 102.
In the mass spectrum of ethyl propanoate, **the peak for the unfragmented molecular ion would appear at the m/e ratio of 102**. This m/e assumes a charge of +1 on the molecular ion.
- Q8 A** When nitric acid acts as an oxidant, it oxidises another species and is itself reduced. As a result of being reduced there will be a decrease in the oxidation number of nitrogen.
In HNO_3 the oxidation number of N is +5
In NO_3^- , the oxidation number of N is +5
In N_2 , the oxidation number of N is 0
In NO, the oxidation number of N is +2
In NO_2 , the oxidation number of N is +4
Hence NO_3^- will not be produced when HNO_3 acts as an oxidant.

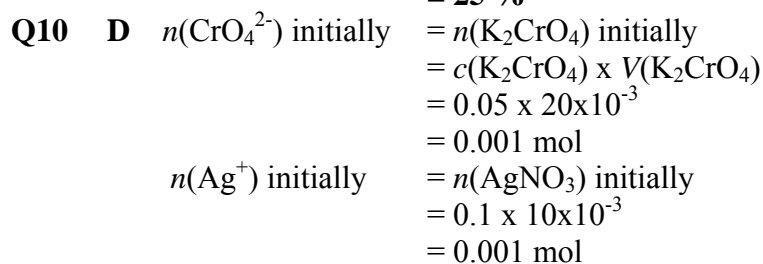
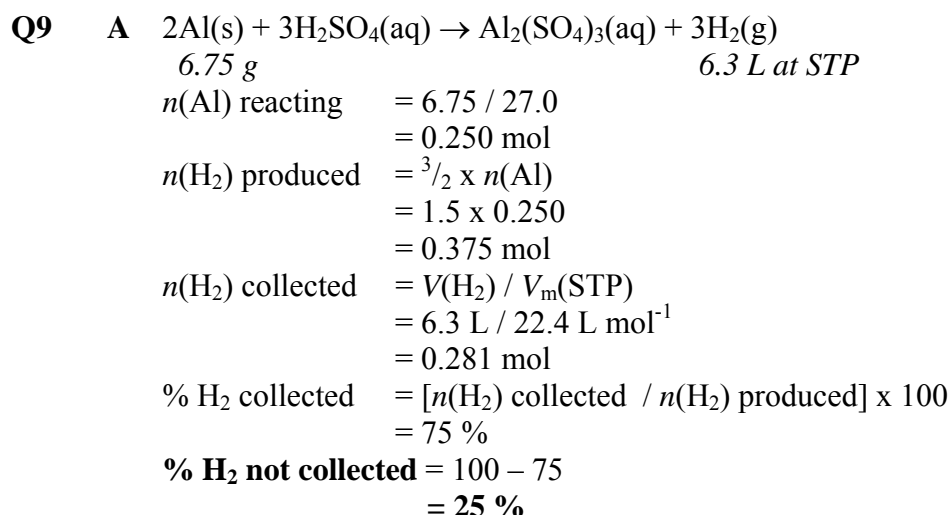

Since $\text{Ag}^+(\text{aq})$ and $\text{CrO}_4^{2-}(\text{aq})$ react in the ratio 2 : 1, i.e. 0.001 mol Ag^+ will react with $0.001 / 2 = 0.0005 \text{ mol CrO}_4^{2-}$, then CrO_4^{2-} is in excess and will not all of it will be precipitated.

Considering the reactants in the ratio indicated by the equation

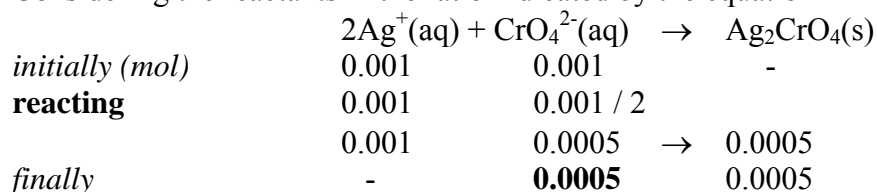

CrO_4^{2-} is in excess by 0.0005 mol and will remain unprecipitated at the end of the reaction.

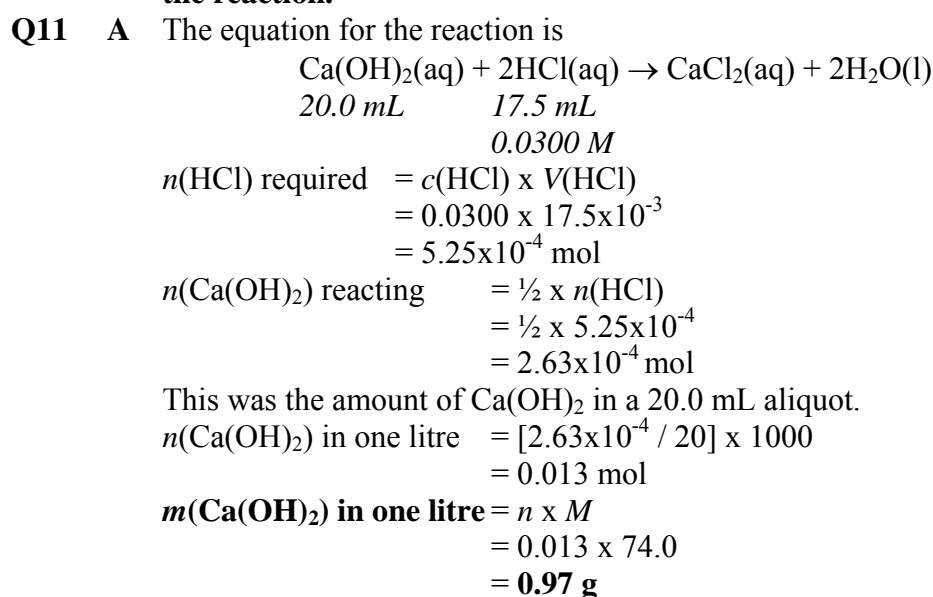

Q12 A The instrument represented is a gas chromatograph.

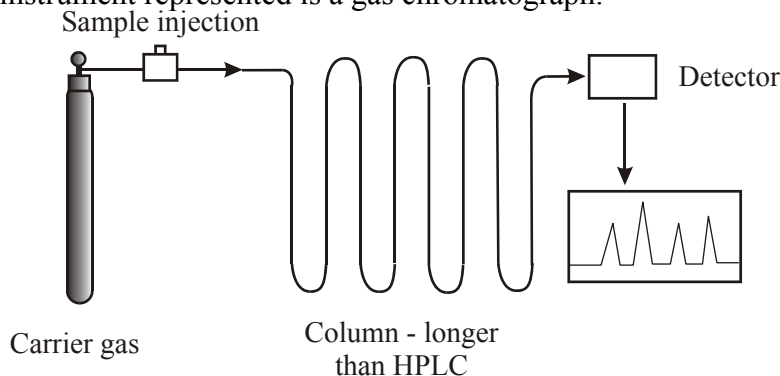

In modern analytical procedures gas chromatography is commonly combined with mass spectroscopy, GC-MS. A complex sample can be separated into its components by gas chromatography and the components then identified using mass spectroscopy.

Q13 D **Table 8** in the VCE Data Book indicates that all amino acids contain C, H, O and N and some contain S.

Nucleic acids on the other hand all contain C, H, N, O and P.

Phosphorus is not present in amino acids.

Sulfur is not present in nucleic acids.

Q14 B **Table 8** in the VCE Data Book shows the structures of all the α -amino acids and should be used to identify the ones present (or missing) from the protein chain.

The amino acids which reacted to form the section of protein chain shown can be deduced from the 'Z' groups, as shown below.

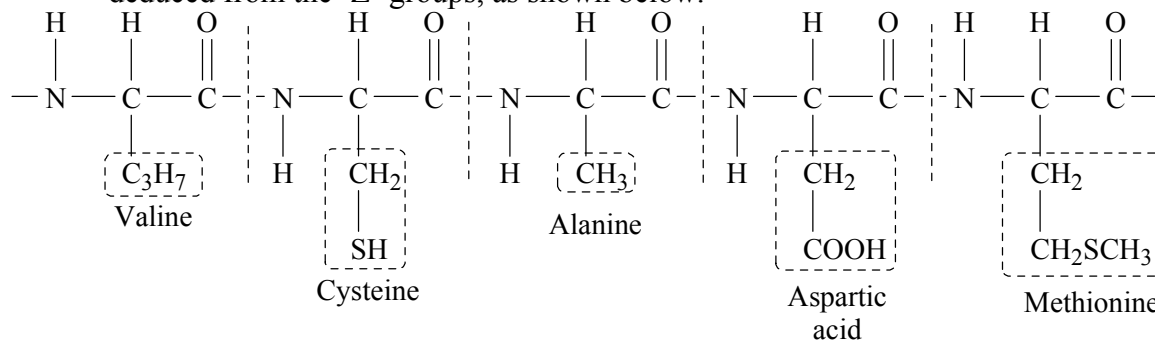

Glycine was not one of the amino acids used to produce this protein section.

Alternatively you may recall that glycine, $\text{NH}_2\text{CH}_2\text{COOH}$, is the simplest amino acid, and inspection shows that it is not part of the protein chain.

Q15 D The **primary structure** of DNA consists of a backbone of **alternating units of deoxyribose and phosphate groups**. The bonds between the deoxyribose and phosphate groups are **covalent bonds**. A **base – adenine, guanine, cytosine or thymine** - is also **covalently bonded to each deoxyribose unit**. Each combination of phosphate group, deoxyribose and base is called a nucleotide and each strand of DNA is described as a **polynucleotide**.

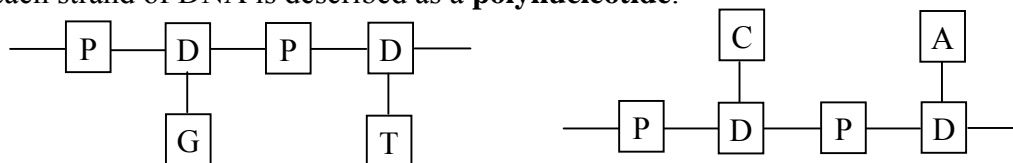

The **secondary structure** of DNA and the **double helix** is due to the **attraction between two polynucleotide strands by hydrogen bonding between complementary bases**. To maintain the constant distance between the two strands **guanine on one strand is always bonded to cytosine on the other strand**, and **adenine on one strand is always bonded to thymine on the other strand**.

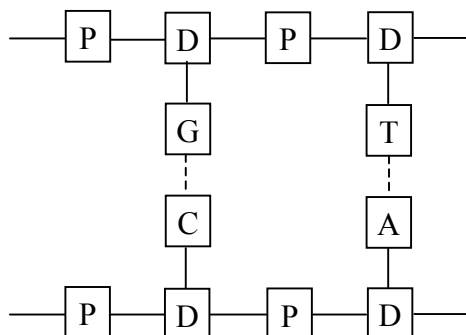

Alternative D is the best alternative.

- Q16 D** Substances that increase the rate of a chemical reaction are generally described as catalysts. However **enzymes are a specific type of catalyst**, in that they are **proteins** and depend on a specific structural aspect, the active site for their catalytic action,

Not all proteins are enzymes, but all enzymes are proteins.

An enzyme **increases the rate of a specific biological reaction**.

Enzymes, like other proteins are prone to denaturation when exposed to changes in pH or temperature.

D is the best alternative.

- Q17 B** The diagram shown in the question is representative of the secondary structure of a protein, which is held together by **hydrogen bonds between different peptide groups on the protein chain**. The hydrogen bonds, indicated by **1.**, occur between the H atom on one peptide group and the O atom on another peptide group.

The bond indicated by **2.** is the **bond between the N and C atoms in the peptide links**. This is a **covalent bond**.

- Q18 A** **Glucose** has the molecular formula **C₆H₁₂O₆**.

The structure of deoxyribose is shown in Table 10. of the VCE Data Book.

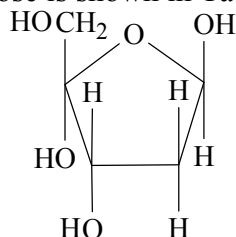

Recognising that there are four C atoms in the ring, the molecular formula of deoxyribose can be deduced as **C₅H₁₀O₄**.

Hence a molecule of deoxyribose has **one less C** atom, two fewer H atoms, and two fewer O atoms than a molecule of glucose.

- Q19** A The analytical process referred to is Atomic Absorption Spectroscopy (AAS), which is most suitable for measuring amounts of metals extracted into or present in solution.

Consider the techniques most suited to analyses described in the alternatives.

- A. Atomic absorption spectroscopy.
B. IR spectroscopy
C. ^{13}C NMR spectroscopy
D. Gas chromatography or redox titration.
- Q20** A The structural formula of 2-methylpropane indicates that there are only **two different hydrogen environments**.

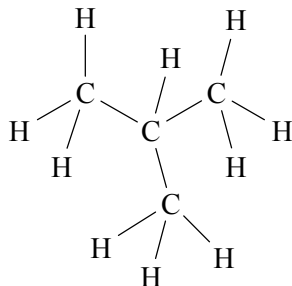

The **9 H atoms in the three CH_3 groups are all equivalent**, i.e. in similar environments in that all 9 are bonded to a C atom which is bonded to two other H atoms and one other C atom.

There is **one other H atom which is bonded to a C atom which is bonded to three other C atoms**.

This also emphasised in the semi-structural formula $(\text{CH}_3)_3\text{CH}$.

Because there are **9 H atoms in one environment and 1 H atom in the other environment**, the **ratio of the areas under the peaks** for the two environments on the ^1H NMR spectrum will be **9 : 1 or 1 : 9**.

Section B

Question 1

a. The **absorbances** of series of **standards of known concentration of $\text{Cu}(\text{NH}_3)_4^{2+}(\text{aq})$** obtained at **600 nm**. ❶

b.

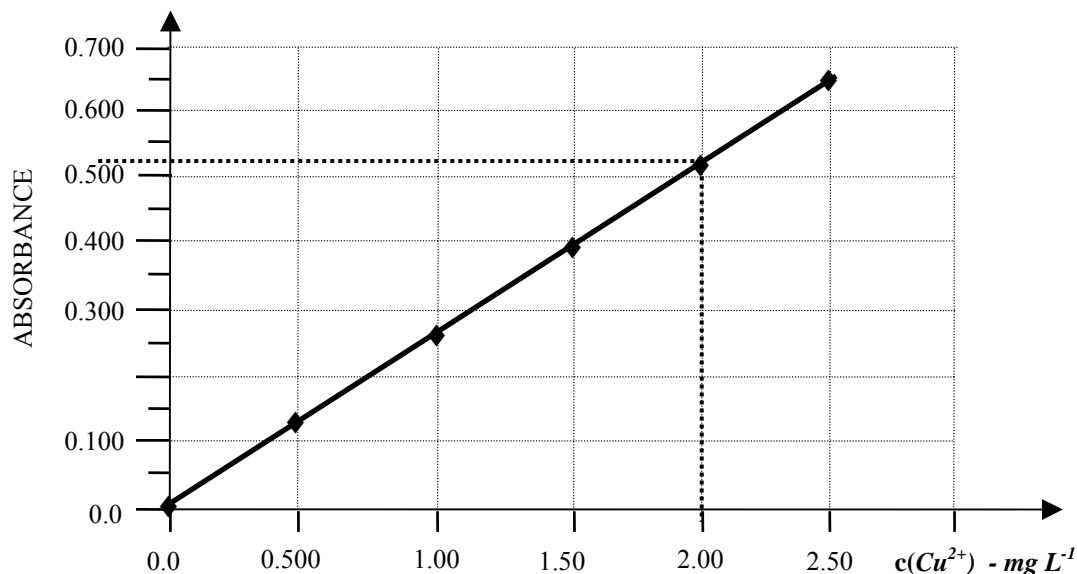

Absorbance 0.520 $\rightarrow c(\text{Cu}^{2+}) = 2.00 \text{ mg L}^{-1}$ ❶

This is the concentration of the solution after the second dilution.

The first dilution was by a **factor of 10**,

i.e. 10 mL of original solution \rightarrow 100 mL of first diluted solution.

The second dilution was by a **factor of 20**

i.e. 5 mL of first diluted solution \rightarrow 100 mL of second diluted solution.

So the solution analysed (second diluted solution) was $\frac{1}{200}$ th (one-two hundredth) as concentrated as the original solution, i.e. $(\frac{1}{10} \times \frac{1}{20})$, i.e. the original solution was 200 times as concentrated as the second dilute solution.

$c(\text{Cu}^{2+})$ in original solution = $200 \times 2.00 \text{ mg L}^{-1}$ ❶
= 400 mg L^{-1}

$n(\text{Cu}^{2+})$ in one L of original solution = $400 \times 10^{-3} \text{ g} / 63.6 \text{ g mol}^{-1}$
= $6.29 \times 10^{-3} \text{ mol}$

$c(\text{Cu}^{2+})$ in original solution = **$6.29 \times 10^{-3} \text{ mol L}^{-1}$** ❶

c. Yellow is the complementary colour of dark blue. Aqueous solutions of $\text{Cu}(\text{NH}_3)_4^{2+}$ ions appear dark blue because they absorb yellow wavelengths from incident white light and transmit blue light. ❶ The higher the concentration of $\text{Cu}(\text{NH}_3)_4^{2+}(\text{aq})$ the greater the absorbance of yellow light. ❶

d. Atomic absorption spectroscopy (AAS) ❶

Light source is a copper cathode lamp. ❶

Question 2

- a. Table 11 of the VCE Data Book provides information about indicator colours.

Colour change: **red to colourless** ①

[For the reaction $\text{HCl}(\text{aq}) + \text{Na}_2\text{CO}_3(\text{aq}) \rightarrow \text{NaHCO}_3(\text{aq}) + \text{NaCl}(\text{aq})$ the original solution in the titration flask was basic due to $\text{Na}_2\text{CO}_3(\text{aq})$. $\text{Na}_2\text{CO}_3(\text{aq})$ contains the strongly basic $\text{CO}_3^{2-}(\text{aq})$. $[\text{Na}_2\text{CO}_3(\text{aq}) \rightarrow 2\text{Na}^+(\text{aq}) + \text{CO}_3^{2-}(\text{aq})$. So the original bath salts solution is of high pH $[\text{CO}_3^{2-}(\text{aq}) + \text{H}_2\text{O}(\text{l}) \rightarrow \text{HCO}_3^-(\text{aq}) + \text{OH}^-(\text{aq})]$ and the phenolphthalein is red (pH > 10)

The addition of $\text{HCl}(\text{aq})$ converts $\text{CO}_3^{2-}(\text{aq})$ to $\text{HCO}_3^-(\text{aq})$ $[\text{CO}_3^{2-}(\text{aq}) + \text{H}^+(\text{aq}) \rightarrow \text{HCO}_3^-(\text{aq})]$.

*When all the $\text{CO}_3^{2-}(\text{aq})$ has been converted to the **slightly basic $\text{HCO}_3^-(\text{aq})$** , the pH drops below 10 and the colour of the phenolphthalein indicator fades through pink to colourless.]*

- b. According to $\text{HCl}(\text{aq}) + \text{Na}_2\text{CO}_3(\text{aq}) \rightarrow \text{NaHCO}_3(\text{aq}) + \text{NaCl}(\text{aq})$

$$\begin{aligned}n(\text{Na}_2\text{CO}_3) \text{ present} &= n(\text{HCl}) \text{ required to reach phenolphthalein endpoint. } \textcircled{1} \\ &= c(\text{HCl}) \times V(\text{HCl}) \\ &= 0.1020 \text{ mol L}^{-1} \times 10.25 \times 10^{-3} \text{ L} \\ &= \mathbf{1.046 \times 10^{-3} \text{ mol}} \quad \textcircled{1}\end{aligned}$$

- c. $n(\text{HCl})$ used is based on the volume added after the phenolphthalein endpoint.

$$\begin{aligned}n(\text{HCl}) &= c(\text{HCl}) \times V(\text{HCl}) \\ &= 0.1020 \times 25.35 \times 10^{-3} \\ &= \mathbf{2.586 \times 10^{-3} \text{ mol}} \quad \textcircled{1}\end{aligned}$$

- d. Table 11 of the VCE Data Book provides information about indicator colours.

Colour change: **yellow to red** ①

[For the reaction $\text{HCl}(\text{aq}) + \text{NaHCO}_3(\text{aq}) \rightarrow \text{NaCl}(\text{aq}) + \text{H}_2\text{O}(\text{l}) + \text{CO}_2(\text{g})$ the original solution in the titration flask was basic due to $\text{NaHCO}_3(\text{aq})$, the pH was above 7 (and 4.4) so methyl orange was yellow. When all the basic $\text{HCO}_3^-(\text{aq})$ has reacted with HCl , the indicator colour changes when the solution becomes slightly acidic and pH drops below 4.4. The colour passes quickly through orange to red.]

- e. According to $\text{HCl}(\text{aq}) + \text{NaHCO}_3(\text{aq}) \rightarrow \text{NaCl}(\text{aq}) + \text{H}_2\text{O}(\text{l}) + \text{CO}_2(\text{g})$

$$\begin{aligned}n(\text{NaHCO}_3) \text{ reacting} &= n(\text{HCl}) \text{ added between endpoints.} \\ &= \mathbf{2.586 \times 10^{-3} \text{ mol}} \quad \textcircled{1}\end{aligned}$$

- f. The NaHCO_3 reacting in (d) included the NaHCO_3 in the original 50.00 aliquot of bath salts solution as well as the NaHCO_3 produced between the first reaction between Na_2CO_3 and HCl .

$$\begin{aligned}n(\text{NaHCO}_3) \text{ in original bath salts solution} \\ &= n(\text{NaHCO}_3) \text{ reacting in (d)} - n(\text{NaHCO}_3) \text{ produced in (b)} \\ &= 2.586 \times 10^{-3} - 1.046 \times 10^{-3} \\ &= \mathbf{1.540 \times 10^{-3} \text{ mol}} \quad \textcircled{1}\end{aligned}$$

$$\begin{aligned}c(\text{NaHCO}_3) \text{ in original bath salts solution} \\ &= 1.540 \times 10^{-3} \text{ mol} / 50.0 \times 10^{-3} \text{ L} \\ &= \mathbf{0.03080 \text{ M}} \quad \textcircled{1}\end{aligned}$$

- g. The **calculated amount of NaHCO_3** would be **higher** than the true value. ①

Traces of bath salts solution would remain in the burette and **some of the HCl** added **would react** with the Na_2CO_3 and NaHCO_3 in those traces. This would effectively **decrease the concentration of the $\text{HCl}(\text{aq})$** in the burette leading to **larger titres** and a **higher calculated amount of NaHCO_3** . ①

Question 3

- a. i. $C_6H_{12}O_6(aq) \rightarrow 2C_2H_6O(aq) + 2CO_2(g)$ *or*
 $C_6H_{12}O_6(aq) \rightarrow 2CH_3CH_2OH(aq) + 2CO_2(g)$ ❶❶
One mark for correctly balanced equation; one mark for correct states.
- ii. Biofuels are fuels produced from **renewable organic sources such as plant materials**, e.g. sugar cane or various grains as a source of sugars for fermentation. ❶
- iii. $C_2H_4(g) + H_2O(g) \rightarrow C_2H_6O(g)$ *or* $CH_2=CH_2(g) + H_2O(g) \rightarrow CH_3CH_2OH(g)$ ❶

b.

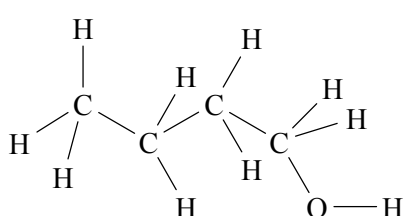

1-butanol

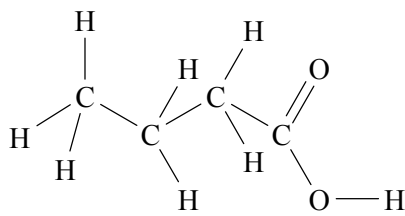

butanoic acid

ii. **butanoic acid** ❶

Both compounds would be expected to show four distinct peaks or sets of peaks because there are four different hydrogen environments on each molecule.

According to the information in Table 5 of the VCE Data Book, the single peak at chemical shift 11.5 would be produced by the proton in a carboxyl $-COOH$ group. ❶

If the compound was **1-butanol** a **peak would be expected** around chemical shift **3.6** for the proton in the $-OH$ group ❶

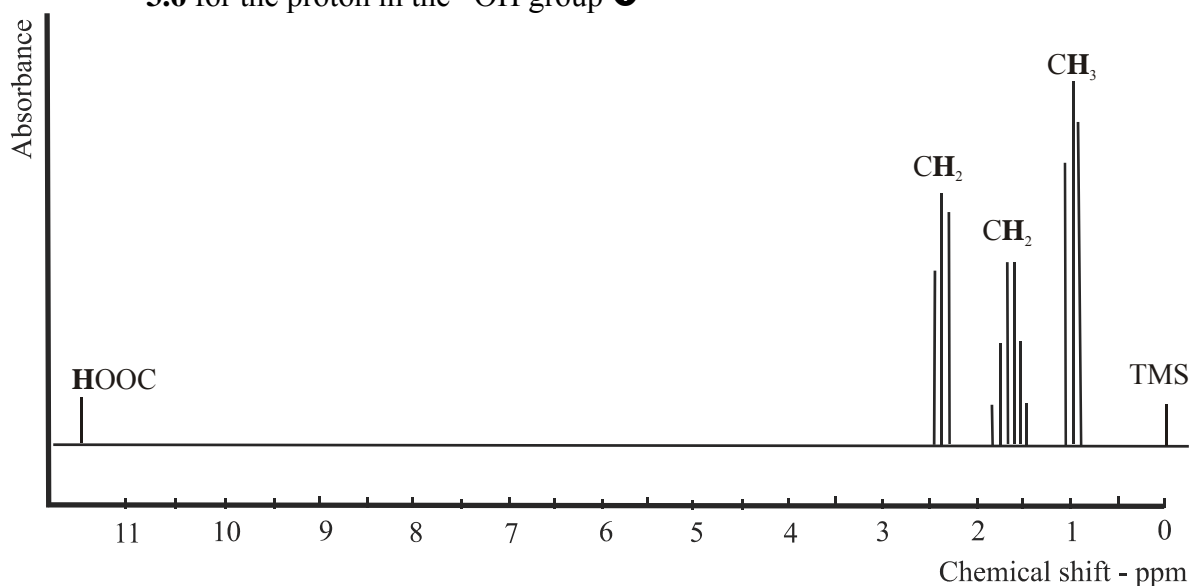

- iii. 1-butanol, $CH_3CH_2CH_2OH$, and ethanol, CH_3CH_2OH , molecules both have the **polar hydroxyl group which allows for hydrogen bonding with water molecules**. Their **solubility in petrol** is due to attraction between their **non-polar hydrocarbon sections** and non-polar octane molecules. ❶ Because **1-butanol molecules have a longer hydrocarbon section** they dissolve more easily in petrol and less readily in water than ethanol molecules. ❶

c. i. **Glycerol 1**

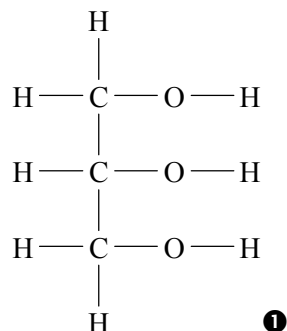

1

ii. The monounsaturated fatty acid produced during hydrolysis of the oil has the chemical formula

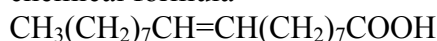

To produce the methyl ester it must be reacted with methanol, CH_3OH , according to the equation

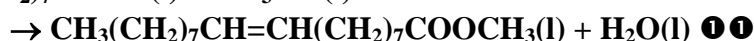
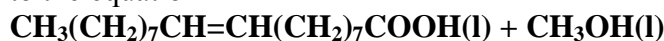

One mark for the correct fatty acid formula

One mark for the balanced equation

d. Whilst combustion of biofuels does produce CO_2 , the carbon being released into atmosphere is the same **carbon that was taken in by the plant**, which was the source of the biofuel, **during photosynthesis.** 1 Fossil fuel combustion releases carbon that has been trapped for millions of years.

Question 4

a. i. **hydroxy group –OH** (in an alcohol) 1 Table 7 VCE Data Book

ii. **fingerprint region** 1

b. i. The largest significant m/e ratio is at 60, so the relative molecular mass is **60** 1

ii. **3 carbon atoms** 1

The compound is an alcohol and had has a relative molecular mass of 60.

Relative mass of C and H atoms = 60 – relative mass of OH

$$= 60 - 17$$

$$= 43$$

Since each carbon atom has an atomic mass of 12, there will be 3 C atoms present.

1

Alternatively check the known alcohols

$M_r(\text{CH}_3\text{OH}) = 32$, $M_r(\text{CH}_3\text{CH}_2\text{OH}) = 46$, $M_r(\text{CH}_3\text{CH}_2\text{CH}_2\text{OH}$ or $(\text{CH}_3)_2\text{CHOH}) = 60$.

c. i. **Four (4)** 1

Four different sets of peaks imply four different hydrogen environments.

ii. **$\text{CH}_3\text{CH}_2\text{CH}_2\text{OH}$** 1

Knowing from the IR and mass spectra data that the compound is an alcohol with 3 C atoms, four sets of peaks on the ^1H NMR spectra are consistent with 1-propanol, $\text{CH}_3\text{CH}_2\text{CH}_2\text{OH}$

iii. For a peak to be split into a triplet the **hydrogen atoms in that environment must have a neighbouring CH_2 group**, i.e. must have 2 neighbouring hydrogens.

1 A CH_2 splits the ^1H NMR signal for hydrogens attached to adjacent carbon atoms into $2+1 = 3$ peaks – the $(n+1)$ rule.

- iv. The sextet peak set is the peak for the two hydrogens on the CH_2 between CH_3 and the other CH_2 . i.e. $\text{CH}_3\text{CH}_2\text{CH}_2\text{OH}$. These **two H atoms have 5** (3 on the adjacent CH_3 and 2 on the adjacent CH_2) **neighbouring H atoms** and so their **peak is split into $5 + 1 = 6$ finer peaks.** ①
- d. **Three (3)** ①
There are three different carbon environments, hence 3 peaks on the ^{13}C NMR spectrum.
- e. i. The other isomer is 2-propanol, $(\text{CH}_3)_2\text{CHOH}$
- ①
- ii. 3 Peaks – ^1H NMR spectrum. ①
The ^1H NMR spectrum will show 3 peaks because there are *three different hydrogen environments* – the CH_3 groups, the CH group, and the OH group. The 6 H atoms on the two CH_3 groups are all in the same environment.
2 Peaks – ^{13}C NMR spectrum. ①
The ^{13}C spectrum will show 2 peaks because there are two different carbon environments; the CH_3 groups and the CH group.

Question 5

- a. Cells in cancerous **tumours and damaged or diseased organs can leak proteins** into blood, urine and other body fluids. These proteins may be ones that are **not normally found in these body fluids or abnormal levels of expected proteins**. These proteins are **called marker proteins**, can be extracted and identified (using electrophoresis and mass spectroscopy) and used to **detect the presence and/or progress of a disease.** ①
- b. **Condensation** reaction ①
Carboxyl (-COOH) and amino (-NH₂) ① functional groups react to **produce a peptide** (amide) (-CONH-) functional group (and water). ①
- c. i. The gel pH will determine whether an amino acid assumes a (+) charge, a (-) charge, or is a zwitterion.
At **low pH**, an **amino acid will act as a base**, accept a proton, **assume a (+) charge and migrate towards the (-) electrode.** ①
At **high pH**, an **amino acid will act as an acid**, donate a proton, **assume a (-) charge and migrate towards the (+) electrode.** ①
At a pH at which an amino acid is a zwitterion it will not migrate to either electrode.
- ii. At pH 2, cysteine $\text{NH}_2\text{CH}(\text{CH}_2\text{SH})\text{COOH}$ will accept a proton and become $^+\text{NH}_3\text{CH}(\text{CH}_2\text{SH})\text{COOH}$. It will migrate towards the **negative electrode.** ①
(Structure of cysteine obtained from Table 8 in the VCE Data Book.)
- d. **Mass spectrometer.** ①

Question 6

a. **amide** group and **hydroxyl** group. ①

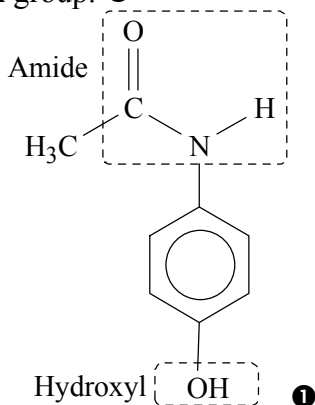

b. **carboxyl** group and **ester** group. ①

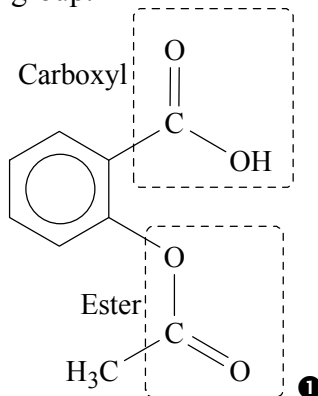

c.

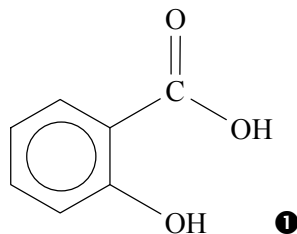

- d. i. It contains **caffeine**, **aspirin** and at least one other substance which appears **not to be paracetamol** ① because its R_F value is different. ①
- ii. **HPLC** (High Performance Liquid Chromatography) ①

End of Suggested Answers