

Student Name: _____



BIOLOGY 2020

Unit 2

Key Topic Test 1 – The cell cycle, asexual and sexual reproduction

Recommended writing time*: 45 minutes

Total number of marks available: 45 marks

QUESTION BOOK

* The recommended writing time is a guide to the time students should take to complete this test. Teachers may wish to alter this time and can do so at their own discretion.

Conditions and restrictions

- Students are permitted to bring into the room for this test: pens, pencils, highlighters, erasers, sharpeners and rulers.
- Students are NOT permitted to bring into the room for this test: blank sheets of paper and/or white out liquid/tape.
- A calculator is NOT permitted in this test.

Materials supplied

- Question and answer book of 10 pages.

Instructions

- Print your name in the space provided on the top of the front page.
- All written responses must be in English.

Students are NOT permitted to bring mobile phones and/or any other unauthorised electronic communication devices into the room for this test.

SECTION A – Multiple-choice questions

Instructions for Section A

Select the response that is correct for the question. A correct answer scores 1 mark, and an incorrect answer scores 0. Marks are not deducted for incorrect answers. If more than one answer is selected for any question, no mark will be given for that question.

Question 1

The complex of DNA and protein in a eukaryotic cell that can be condensed to become visible is called:

- A. chromosome
- B. centromere
- C. chromatin
- D. chromatid

Question 2

During growth and development of eukaryotic organisms, new cells need to be produced. These new cells are produced by:

- A. binary fission
- B. mitosis
- C. meiosis
- D. cytokinesis

Question 3

Mitosis involves several stages. The correct sequence of these stages is:

- A. anaphase, telophase, metaphase, cytokinesis, prophase
- B. prophase, metaphase, anaphase, telophase, cytokinesis
- C. interphase, anaphase, telophase, metaphase, prophase
- D. interphase, anaphase, prophase, metaphase, telophase

Question 4

The reason that bacteria can show a very rapid increase in numbers if they are in an ideal environment is because:

- A. their cell cycle is very rapid
- B. they breed quickly
- C. they can divide into more than two parts at a time
- D. their numbers are being squared at each cell cycle

Question 5

How does the cell cycle in prokaryotes differ from that in eukaryotes?

- A. the cell cycle in prokaryotes is more complex than in eukaryotes
- B. the cell cycle in prokaryotes is simpler than in eukaryotes
- C. the cell cycle in prokaryotes does not require DNA duplication whereas this is a necessary part of the cell cycle in eukaryotes
- D. the cell cycle in prokaryotes produces clones whereas the cell cycle in eukaryotes produces two daughter cells

Question 6

Which of the following options is not an advantage of sexual reproduction?

- A. all individuals are identical
- B. offspring display characteristics different to each other and to that of their parents
- C. the genetic diversity of the population is maintained
- D. some offspring are more likely to survive in a changing environment.

Question 7

An essential contribution to genetic diversity is:

- A. crossing over during prophase I of meiosis
- B. crossing over during prophase I of mitosis
- C. the division of chromatids during anaphase II of meiosis
- D. the division of chromatids during anaphase II of mitosis

Question 8

Chromatids sometimes fail to separate during gamete formation. This can lead to:

- A. a point mutation
- B. twins
- C. aneuploidy
- D. asexual reproduction

Question 9

If a student was preparing a presentation about asexual reproduction, what word or phrase below would be out of place?

- A. clone
- B. gamete
- C. binary fission
- D. vegetative propagation

Question 10

Public attitudes towards cloning are mixed. Which statement below is not true?

- A. artificial cloning of plants involves plant tissue culture
- B. currently the law in Australia prevents human cloning
- C. artificial cloning of animals is proving to be a very successful process
- D. nuclear transfer involves the transfer of the nucleus of an adult body cell to an egg cell that has had its nucleus removed

SECTION B- Short-answer questions

Instructions for Section B
Answer all parts of the question in the space provided. Write using black or blue pen.

Question 1

- a. On the diagram of a duplicating chromosome below, label the following:



- i. Centromere
- ii. Chromatid
- iii. The loci of a gene
- iv. Draw a homologous chromosome

1 + 1 + 1 + 1 = 4 marks

- b. Explain the difference between chromatin and a chromosome.

2 marks

Total 6 marks

Question 2

The diagrams below show some of the different stages of mitosis.

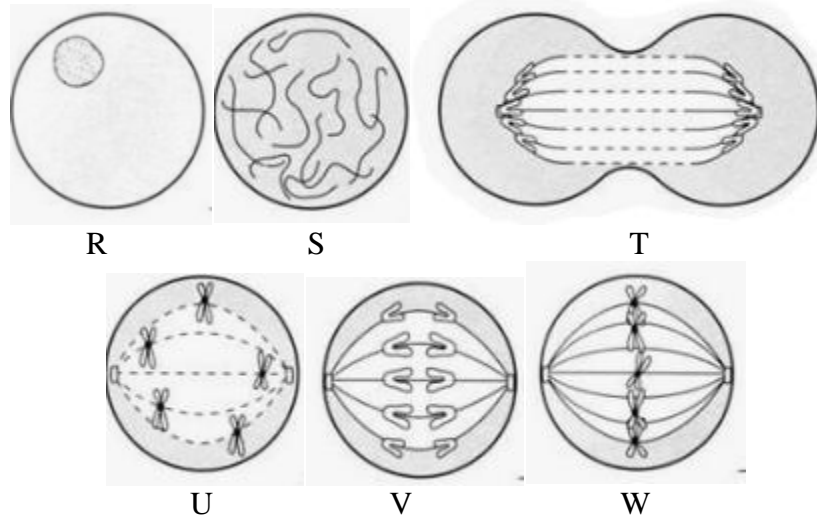

a. The correct order for these stages is:

_____ 1 mark

b. Which letter represents the stage of metaphase? _____

1 mark

c. What is the purpose of mitosis?

2 marks

Total 4 marks

Question 3

The diagram below represents the stages of the cell cycle in eukaryotes.

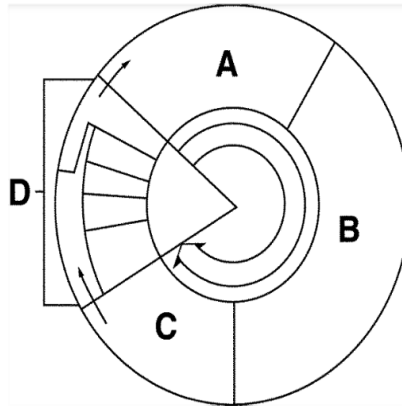

a. Name and describe what is happening at stages A, B, C and D of the diagram.

i. Stage A

ii. Stage B

iii. Stage C

iv. Stage D

2 + 2 + 2 + 2 = 8 marks

b. What is the name of the major phase that cells spend most of their time in?

1 mark

Total 9 marks

Question 4

The graph below represents the quantity of DNA in a cell as it goes through one cell cycle.

- a. Describe what is occurring at A and B

2 marks

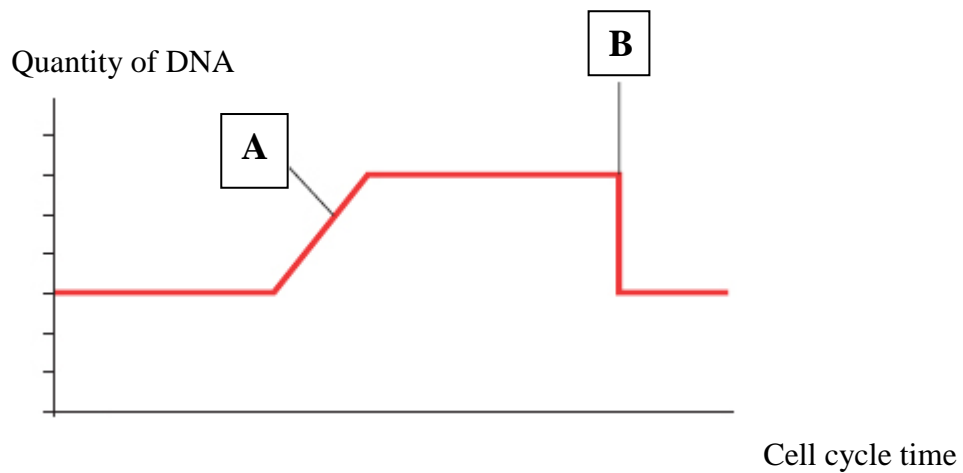

- b. Mark and name the stages of the cell cycle along the x axis of the graph above, that correspond to the 4 different changes in the quantity of DNA.

4 marks

Total 6 marks

Question 5

Compare and contrast cytokinesis in plants and animals. You may use simple diagrams to aid your explanation.

Total 4 marks

Question 6

- a. Complete the following table listing different methods of asexual reproduction and some examples of organisms that can reproduce that way.

Organism	Method of asexual reproduction	Description
Bacteria		
	Budding	
		Part of a plant is stimulated to form another identical new plant
Fungi		

½ mark each = 4 marks

b.

i. Describe one advantage of asexual reproduction.

ii. Describe one disadvantage of asexual reproduction

1 + 1 = 2 marks

Total 10 marks

END OF KEY TOPIC TEST