

STUDENT NUMBER           Letter

## ALGORITHMICS (HESS)

### Written examination

Monday 2 November 2015

Reading time: 11.45 am to 12.00 noon (15 minutes)

Writing time: 12.00 noon to 2.00 pm (2 hours)

### QUESTION AND ANSWER BOOK

#### Structure of book

<i>Section</i>	<i>Number of questions</i>	<i>Number of questions to be answered</i>	<i>Number of marks</i>
A	20	20	20
B	14	14	80
			Total 100

- Students are permitted to bring into the examination room: pens, pencils, highlighters, erasers, sharpeners, rulers and one scientific calculator.
- Students are NOT permitted to bring into the examination room: blank sheets of paper and/or correction fluid/tape.

#### Materials supplied

- Question and answer book of 23 pages.
- Answer sheet for multiple-choice questions.

#### Instructions

- Write your **student number** in the space provided above on this page.
- Check that your **name** and **student number** as printed on your answer sheet for multiple-choice questions are correct, **and** sign your name in the space provided to verify this.
- All written responses must be in English.

#### At the end of the examination

- Place the answer sheet for multiple-choice questions inside the front cover of this book.

**Students are NOT permitted to bring mobile phones and/or any other unauthorised electronic devices into the examination room.**

**SECTION A – Multiple-choice questions****Instructions for Section A**

Answer **all** questions in pencil on the answer sheet provided for multiple-choice questions.

Choose the response that is **correct** or that **best answers** the question.

A correct answer scores 1, an incorrect answer scores 0.

Marks will **not** be deducted for incorrect answers.

No marks will be given if more than one answer is completed for any question.

**Question 1**

Q.enqueue(6)

Q.enqueue(3)

Q.dequeue()

Q.enqueue(2)

Q.dequeue()

Given an empty queue Q, what does Q look like after the operations above?

- A. 6
- B. 3
- C. 2
- D. It is empty.

*Use the following information to answer Questions 2 and 3.*

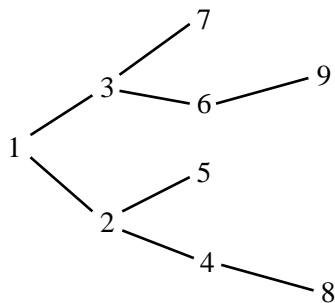
**Question 2**

The first six nodes visited, starting at node 1, in a depth-first search could be

- A. 123456
- B. 124637
- C. 124853
- D. 136798

**Question 3**

The first six nodes visited, starting at node 1, in a breadth-first search could be

- A. 124653
- B. 123456
- C. 124563
- D. 123458

**Question 4**

Eight network devices are arranged so that every device is connected to every other device by a single link. The total number of links can be calculated by

- A.  $8^2$
- B.  $8^2 - 1$
- C.  $\log 8$
- D.  $8 \frac{(8-1)}{2}$

**Question 5**

A graph that is a tree where each edge weight appears a maximum of two times can have

- A. only one minimal spanning tree.
- B. only two minimal spanning trees.
- C. only three minimal spanning trees.
- D. four or more minimal spanning trees.

**Question 6**

To guarantee a unique minimal spanning tree in a graph

- A. there must be no cycles.
- B. running Prim's algorithm is sufficient.
- C. each edge must have a unique weight.
- D. repeated edge weights must be odd in number.

**Question 7**

To show that  $(u, v)$  is in the transitive closure of graph  $G$ , it is necessary to show that

- A. a  $u-v$  path exists in  $G$ .
- B. no  $u-v$  path exists in  $G$ .
- C.  $G$  is a connected graph.
- D.  $u$  and  $v$  have the same degree.

**Question 8**

Which one of the following statements is correct?

- A. All directed graphs are also undirected graphs.
- B. Undirected graphs can also be represented as directed graphs.
- C. There is no relationship between directed and undirected graphs.
- D. Only undirected graphs with positive edge weights can be represented as directed graphs.

**Question 9**

Which one of the following recurrence relations represents the time complexity relationship for mergesort?

- A.  $T(n) = T(n/2) + O(1)$
- B.  $T(n) = 2T(n/2) + O(n)$
- C.  $T(n) = 2T(n/2) + O(\log n)$
- D.  $T(n) = 2T(n/2) + O(n \log n)$

**Question 10**

A search algorithm satisfies the following recurrence relation.

$$T(n) = \begin{cases} T\left(\frac{n}{2}\right) + O(n), & n > 1 \\ O(1) & , n = 1 \end{cases}$$

Which one of the following is the time complexity of this search algorithm?

- A.  $\Theta(n)$
- B.  $\Theta(1)$
- C.  $\Theta(\log n)$
- D.  $\Theta(n \log n)$

**Question 11**

Which one of the following statements may **not** always be true?

- A. A loop invariant is satisfied throughout the loop.
- B. A loop invariant is satisfied immediately before the loop.
- C. A loop invariant is satisfied after each iteration of the loop.
- D. A loop invariant is satisfied immediately after the last iteration of the loop.

**Question 12**

Which one of the following problems is known to be solvable for large values of  $N$  in Polynomial-time?

- A. Find all subsets in  $N$  items.
- B. Find all permutations of  $N$  items.
- C. Find a minimal spanning tree in a graph of  $N$  edges.
- D. Find the solution of the travelling salesman problem with  $N$  nodes.

**Question 13**

When considering computability, the Halting Problem is

- A. complete when executed on a Turing machine.
- B. decidable when executed on a Turing machine.
- C. incomplete when executed on a Turing machine.
- D. undecidable when executed on a Turing machine.

**CONTINUES OVER PAGE**

Use the following information to answer Questions 14 and 15.

A Turing machine is configured with the instructions represented in the state diagram below.

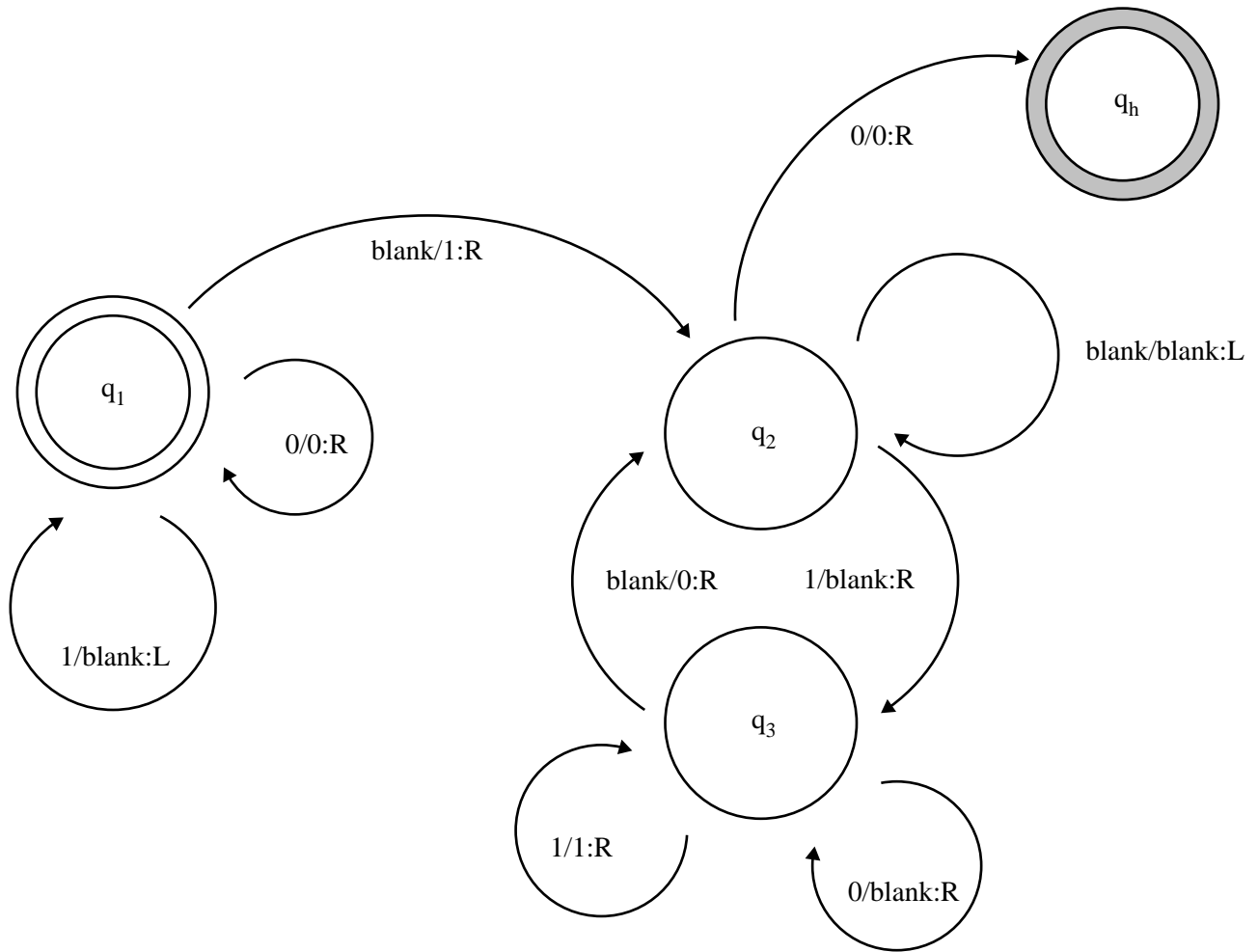

Each edge is labelled  $i / j : k$ , where:

- $i$  is the input
- $j$  is the output
- $k$  is the direction the head moves (L = left, R = right) after the output.

The machine begins in state  $q_1$ .

The machine is given the following tape. For this machine, the tape remains stationary while the head moves. The arrow shows the starting point of the head.

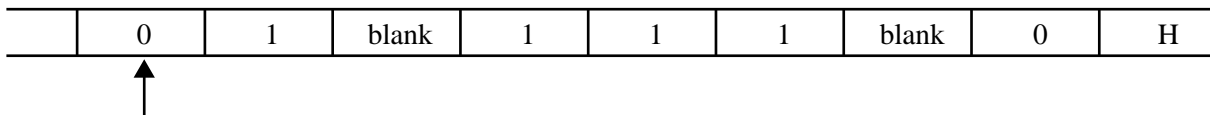

**Question 14**

After the fifth step, the Turing machine will be in

- A. state  $q_2$  and the head will be one position to the right.
- B. state  $q_1$  and the head will be one position to the right.
- C. state  $q_2$  and the head will be two positions to the right.
- D. state  $q_3$  and the head will be two positions to the right.

**Question 15**

Which one of the following best represents the tape's appearance and the position of the head when the Turing machine halts?

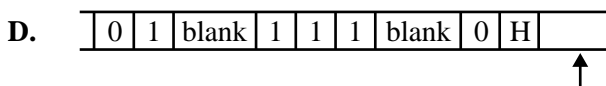
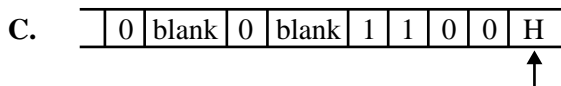
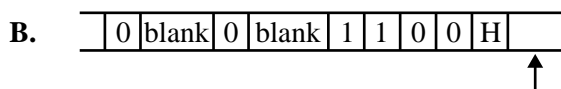
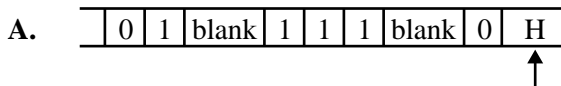

**Question 16**

David Hilbert's 1927 program and its connections to the origin of computer science imply that, if mathematical reasoning is fully formalised, then computers will be able to

- A. solve all mathematical problems.
- B. detect when a mathematical problem is unsolvable.
- C. create different methods of solving a particular mathematical problem.
- D. create different methods of determining if a mathematical problem is unsolvable.

**Question 17**

After measuring the running times of two algorithms, A and B, using increasing size of input  $n$ , the following data is recorded.

$n$	1	2	4	8	16	32
Algorithm A	0	2	8	24	64	160
Algorithm B	1	4	16	64	256	1024

Which Big-O notations best describe the running times of the two algorithms?

- A. Algorithm A is  $O(n)$  and Algorithm B is  $O(n)$ .
- B. Algorithm A is  $O(n)$  and Algorithm B is  $O(n^2)$ .
- C. Algorithm A is  $O(\log n)$  and Algorithm B is  $O(n^3)$ .
- D. Algorithm A is  $O(n \log n)$  and Algorithm B is  $O(n^2)$ .

**Question 18**

Consider the following pseudocode, where the input value,  $n$ , is a positive integer.

```

x = 0
for i in the range of 1 to n
    for j in the range of 1 to n
        x = x + i + j
return x

```

The runtime is best described as

- A.  $O(n)$
- B.  $O(n^2)$
- C.  $O(\log n)$
- D.  $O(n \log n)$



Use the following information to answer Questions 19 and 20.

Consider the following weighted graph.

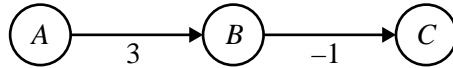

**Question 19**

Which one of the following statements about the graph is true?

- A. There is no finite shortest path from  $A$  to  $C$ .
- B. The shortest path from  $A$  to  $C$  has weight 2.
- C. Dijkstra's algorithm will not terminate on this graph.
- D. The Bellman-Ford algorithm will not terminate on this graph.

**Question 20**

If  $T$  is a set of edges representing a minimal spanning tree of the graph, which one of the following statements is true?

- A.  $T = \{\}$
- B.  $T = \{(A, B)\}$
- C.  $T = \{(B, C)\}$
- D.  $T = \{(A, B), (B, C)\}$

**SECTION B**

**Instructions for Section B**  
Answer **all** questions in the spaces provided.

**Question 1** (3 marks)

The Church-Turing thesis states that a function on natural numbers is manually computable by a human being if, and only if, it can also be computed by a Turing machine.

Explain what this statement means. In your answer, include reference to the limitations of this thesis.

---

---

---

---

---

---

---

---

**Question 2** (4 marks)

a. Describe the difference between an array and a dictionary. 2 marks

---

---

---

---

b. Justify, with **two** real-world examples, when a priority queue is the more suitable abstract data type than a queue. 2 marks

---

---

---

---

**Question 3** (3 marks)

Consider an algorithm that takes as its input a positive whole number,  $n$ , where  $n \geq 3$ . The algorithm computes the number of ways an  $n$ -gon can be divided into  $n-2$  triangles, where different orientations are counted separately.

Given some value of  $n$ , is determining whether the output of the algorithm is equal to some value  $x$  decidable? Justify your answer with reference to limits of computability.

---

---

---

---

---

---

---

---

---

---

**Question 4** (9 marks)

Shara is a scientist who has developed a vaccine for a new type of disease. She left this vaccine on a table overnight and a laboratory monkey stole it. The monkey escaped through a vent into an underground drainage system.

The drainage system consists of a maze-like structure with drains between buildings connecting to other buildings in the area. Shara needs to retrieve the vaccine quickly, but as no human can fit into the underground drainage system, she has approached the robotics department within her organisation to borrow one of its unmanned ground vehicle robots to search the drains and set traps for the monkey. The robot will travel down the drains and search each one, leaving behind a humane trap to capture the monkey if it comes through that drain after the robot has already checked it.

The diagram below shows Shara’s building (labelled ‘A’) and the buildings closest to it, including their drainage connections. It does not show all of the connected buildings in the area.

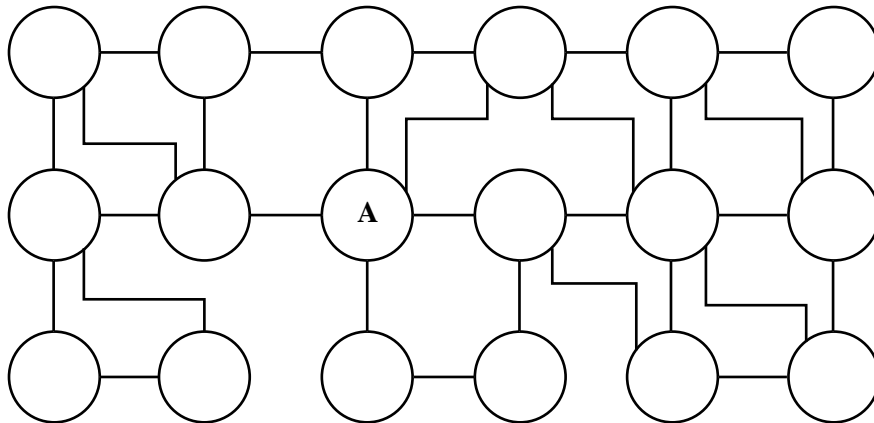

- a. Describe an algorithm that could be used in the robot to search for the monkey. In your answer, explain how the algorithm would meet Shara’s needs.

4 marks

---

---

---

---

---

---

---

---

---

---

- b.** Shara discovers that some of the drains have been partially blocked by different amounts of debris from recent rains. This will need to be considered within the algorithm used in the robot, that is, when searching, the robot should consider the amount of debris blocking each drain.

Describe a method that can be used to accommodate this new condition.

3 marks

---

---

---

---

---

---

---

---

---

---

- c.** If the robot does not find the monkey in the drains shown in the diagram, Shara will need to expand the search area.

Explain **one** consequence this will have in relation to successfully finding the monkey.

2 marks

---

---

---

---



**Question 6** (5 marks)

CallMe Inc. is planning to build an app that helps people find the mobile phone numbers of their friends. The app will automatically detect a caller's name by using speech recognition during a telephone conversation and match the name with the number. This pair (name and telephone number) will then be stored in a database. Assume that the speech recognition is 100% accurate, so that the pairs are always correct.

- a. In addition to inserting name–number pairs, if the only other functionality of the app is to look up a mobile phone number when given a person's name, would a dictionary or a list ADT be better for storing this data? Use Big-O notation to justify your selection. 3 marks

---

---

---

---

---

---

---

---

- b. CallMe Inc. has decided that instead of looking up a mobile phone number when given a person's name, it wants the app to offer a browse function, where the names of people are listed in alphabetical order.

Which ADT could be used for storing the data in this scenario and why? 2 marks

---

---

---

---

**Question 7** (6 marks)

Some black-box tests for an algorithm that computes information about a given node,  $u \in V$ , in a connected, unweighted, undirected graph,  $G(V, E)$ , are required.

- a. The size of the graph is not known in advance, but the number of nodes is limited to be between 1 and  $2^{20}$ .

State the four boundary cases for  $|V|$  that should be tested.

4 marks

---

- b. In terms of  $|V|$ , what is the smallest and largest  $|E|$  that could occur for the graph?

2 marks

---

**Question 8** (5 marks)

A new extension to the National Broadband Network (NBN) is required in rural Australia to connect towns labelled  $A$  to  $I$ . The diagram below represents the roads between towns, with road distances shown (in kilometres). Fibre optic cable is to be placed underground along each road such that the total length of the cable is minimised.

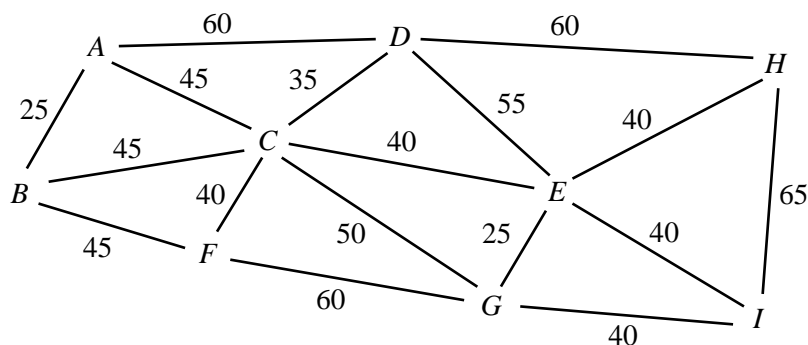

- a. Name an algorithm that can be used to determine the minimum total length of cable needed.

1 mark

---

- b. Draw the connections in the following diagram to minimise the total length of fibre optic cable, thereby the cost of connecting all the towns to the NBN.

4 marks

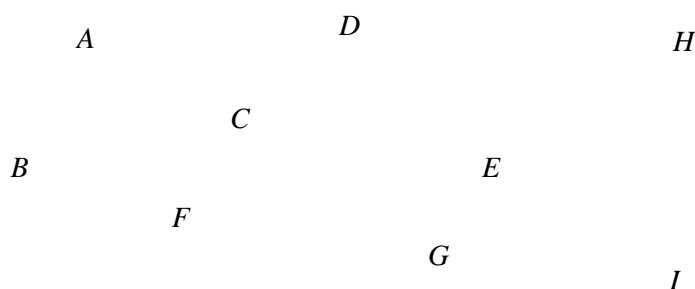





**Question 10** (13 marks)

Consider the following  $6 \times 6$  grid.

<b>START</b>					
	<b>X</b>			<b>X</b>	
			<b>X</b>		<b>X</b>
		<b>X</b>			<b>END</b>

Suppose there is a robot that starts in the cell labelled 'START'. This robot can only move to the immediate right or down and it is not allowed to visit any cells labelled 'X'.

- a.**
- i.** In the grid above, for each blank cell, insert the number of different paths to that cell that the robot could follow. 3 marks
  - ii.** How many different paths can the robot take to get to the cell labelled 'END'? 1 mark
-

- b. Write an algorithm, in pseudocode, that, for a given  $n \times n$  grid, determines the number of different paths from the top-left corner of the grid to the bottom-right corner of the grid. Assume that the elements of the grid are either X, if the robot is not allowed to visit the corresponding cell, or 0, if the robot can visit that cell.

9 marks



**Question 12** (4 marks)

Describe how backtracking could be used to solve the travelling salesman problem.

---

---

---

---

---

---

---

---

---

---

**Question 13** (9 marks)

The following algorithm, named **f**, has three inputs and one output. For this algorithm, index values start at 0.

**Algorithm f(A, i, j)**

First Input: A, an array of integers sorted in increasing order

Second Input: i, a valid index into A

Third Input: j, a valid index into A

If i equals j and A[i] is not equal to i

Output -1

Let m be  $(i+j)/2$  rounded down to the nearest integer

If  $A[m] < m$  then

f(A, m+1, j)

else if  $A[m] > m$  then

f(A, i, m)

else

Output m

- a. Draw a tree representing the execution path of Algorithm **f** if it begins with the following inputs.

$A = [-1, 0, 4, 5, 10, 11, 15, 20]$

$i = 0$

$j = 7$

Include these first inputs as the root of your tree. Each node in the tree is a subsequent call to the algorithm.

6 marks

- b. If  $A$  is any array of  $n$  integers sorted in increasing order, what does  $f(A, 0, n-1)$  compute? 1 mark

---

- c. Write a recurrence relation that gives the worst-case running time of Algorithm  $f$ . 2 marks

---

---

**Question 14** (3 marks)

For a graph  $G$  with  $n$  nodes, a student runs the Bellman-Ford algorithm for  $n-1$  iterations. She then runs one more iteration and notices the shortest path between two nodes has reduced.

- a. What property of  $G$  has the testing established? 1 mark

---

- b. Explain whether the Bellman-Ford algorithm should be used to find a shortest path solution in this example. 2 marks

---

---

---

---